

OCULUS

Pentacam® | Pentacam® HR

Anterior Segment Tomography



INSTRUCTIONS FOR USE

Preface

The Pentacam® / Pentacam® HR (High Resolution) has been manufactured and tested according to strict quality criteria.

- The operating concept of the Oculus Pentacam® and Pentacam® HR is basically identical.
- Additional functions pertaining to the Pentacam® HR (high resolution) are indicated accordingly.

To ensure safe operation, it is essential that you use the device correctly. For this reason you should familiarise yourself thoroughly with the contents of this Instructions for Use before operating the device. In particular, pay attention to the safety instructions in the instructions for use.

The following user information is available for your device:

- **Instructions for Use** describes how to manage patient data, the default settings of the Pentacam® program and the measuring process. The design of the unit is described in detail in this document. The instructions for Use also contain all safety-related instructions of the Pentacam® / Pentacam® HR.
- **User Guide** contains information supplementing the description of the operating concept. All features of the examination and analysis software are described in the User Guide, along with detailed information about the Patient Data Management system.
- **Interpretation Guide Ophthalmology** serves as a support for interpreting measurement results and graphical representations generated with a model from the Pentacam® family.
- **Software Installation** describes how to install the Pentacam® / Pentacam® HR software and the associated drivers.
- **Manual Floating License Key**: information on the use of the Pentacam® / Pentacam® HR within networks.

Due to ongoing development, the figures shown may depict minor changes to the actual device delivered.

If you have any queries or would like additional information about your device, do not hesitate to call or send us an email or a fax. Our service team will gladly assist.

OCULUS Optikgeräte GmbH

Item number: 10039981 / US

Revision: 04

Release: 26.09.2025

Table of Contents

1	Scope of Delivery	9
2	Safety.....	11
2.1	Symbols.....	11
2.1.1	On the device / name plate	11
2.1.2	On the packaging	12
2.1.3	In this Manual.....	12
2.2	Safety Instructions for Use.....	13
2.2.1	Patient environment information	14
2.2.2	Instructions for the operation of a ME system.....	14
2.2.3	Instructions on Electrical Safety	15
2.3	Instructions on Cyber Security	16
2.3.1	Precautions for access control of the computer.....	16
2.3.2	User Responsibility	16
2.3.3	Reporting Device Security or Privacy Breaches.....	17
2.3.4	Recovering from Compromised Accounts or Devices.....	17
2.3.5	Unavailable Service	17
2.3.6	Precautions if the computer is connected to a LAN or internet network.....	17
3	Device Description	18
3.1	Overview of the device components	18
3.2	Applied parts.....	19
3.3	Functionality of the Pentacam® / Pentacam® HR.....	19
3.4	Intended Purpose	20
3.4.1	Intended Use	20
3.4.2	Intended Medical Indication.....	20
3.4.3	Contraindication.....	20
3.4.4	Possible side effects.....	21
3.4.5	Intended users	21
3.4.6	Patient group.....	21
4	Setup and Installation.....	22
4.1	Setup	22
4.2	Installation and Operating Conditions.....	23
4.3	Electrical Connection.....	23
4.4	Switching On	24
4.5	Switching Off.....	24
4.6	Software Installation on separate PCs.....	25
5	Pentacam® Program	26
5.1	Menu Bar in the Pentacam® Programm.....	26
5.2	Scan Screen.....	27
5.2.1	Scheimpflug image settings	28
5.2.2	Parameters applicable only to the Pentacam® HR.....	28

5.3	Loading previous examinations.....	29
5.4	Online help.....	29
5.5	Information for recording Scheimpflug images.....	30
6	Measuring Procedure.....	31
6.1	Default settings.....	32
6.2	Darken the room.....	32
6.3	Rough adjustment.....	32
6.4	Fine Adjustment.....	35
6.5	Quality Specifications.....	36
6.6	Measuring Procedure for Tomography.....	39
6.6.1	Quality Specifications for the Tomography.....	41
6.7	CSP measurement (Pentacam® only).....	43
6.8	CSP Pro measurement (Pentacam® HR only).....	46
6.8.1	Quality specification for CSP Pro Measurement.....	48
6.8.2	Repeat or delete measurement.....	49
7	Patient Data Management.....	52
7.1	Starting Patient Data Management.....	52
7.2	Entering a New Patient.....	53
7.3	Selecting an Existing Patient.....	53
7.4	Extended Patient Search: [Extended] Checkbox.....	54
7.5	Rename Patient Data.....	54
7.6	Exporting Patient Data.....	54
7.7	Importing Patient Data.....	56
7.8	Data Backup.....	57
7.8.1	Backup Data.....	57
7.8.2	Reconstructing Data.....	58
7.8.3	Automatic Backup.....	58
8	Cleaning, Disinfection and Maintenance.....	59
8.1	Intervals for Cleaning, Disinfection and Maintenance.....	59
8.2	Consumables.....	59
8.3	Cleaning.....	59
8.3.1	Cleaning the Housing.....	60
8.3.2	Clean chin rest and forehead rest.....	60
8.3.3	Cleaning the illuminated slit.....	60
8.4	Disinfection.....	60
8.5	Test measurements.....	61
8.6	Maintenance.....	61
8.7	Attaching Paper to the Chin Rest.....	62
9	Troubleshooting.....	63
10	Transport and Storage.....	64
10.1	Storage conditions.....	64
10.2	Transport conditions.....	64

10.3 Disassembly	65
11 Disposal	66
12 Terms of Warranty and Servicing.....	67
13 Technical Data	68
14 Annex.....	70
14.1 Electromagnetic Compatibility	70
14.2 Guidance and Manufacturer's Declaration - Electromagnetic Emissions and Immunity.....	71
14.3 Description of the Connection	75
14.4 Data sheet HEMG 49-S240210-7 (05150150).....	76
14.5 Instructions for integration into an IT-Network.....	78

1 Scope of Delivery

Product and accessories
Pentacam® Pentacam® HR
<ul style="list-style-type: none"> ■ x-y base ■ Support plate ■ Cograil ■ Cover ■ Sliding plate ■ Chin rest paper ■ Head and chin rest
Accessories Package
<ul style="list-style-type: none"> ■ Power supply ■ Dark sheet ■ Washing manual ■ Wire clip ■ Hexagon screwdriver
User Information
<ul style="list-style-type: none"> ■ Instructions for Use ■ User Guide ■ Interpretation Guide ■ Software Installation Manual
Additional accessories
<ul style="list-style-type: none"> ■ Dustcover ■ Hard drive, package ■ Y-cable for Basic with galvanic isolation 2 m ■ Y-cable for HR: Med. secure isolator + USB connection ■ Extension cable for Y cable 4 m ■ Country specific electric cable
Optional software packages
Refractive Package
<ul style="list-style-type: none"> ■ Corneal Optical Densitometry ■ Refractive display ■ Pachymetric display ■ 4 maps selectable ■ Compare 4 exams ■ 2 exams topometric ■ 2 exams pachymetric ■ Corneal rings

Optional software packages

Cataract Package

- PNS and 3D-Cataract analysis
- Cataract Pre-OP display
- Zernike analysis
- Corneal power distribution
- Compare 4 exams
- Show 2 exams topometric
- Show 2 exams pachymetric
- 4 maps topometric
- 4 maps anterior chamber
- Total corneal refractive power (TCRP)
- True net power (TNP)
- Anterior chamber depth
- Anterior chamber angle at Scheimpflug images

Screening Package

- Belin/Ambrosio Display
- Corneal Optical Densitometry
- Shows 2 Exams
- 4 Maps Selectable

Contact Lens Fitting Package (Pentacam® HR only):

- CSP Report (only Pentacam®) / CSP Pro Report
- Contact Lens Fitting Software incl. Fourier Analysis
- Ortho-K Follow-Up
- Zernike analysis
- Compare 4 exams

Single Licenses

- Holladay Report and Holladay EKR Detail Report
- 3D pIOL Simulation and Aging Prediction (only Pentacam® HR)
- IOL Calculator (only Pentacam® HR)
- DICOM

We reserve the right to make changes to the scope of delivery in the course of technical development.

- If you find transport damage upon delivery, immediately file a claim with the transport company.
- Have the damages noted on the bill of lading, so that your claim for damages can be handled properly.

For more information regarding shipping and handling, see → [chap. 10 Transport and Storage, page 65](#).

2 Safety

All safety-related instructions of the device are given in the Instructions for Use only.
 → Read and follow the Instructions for Use.

2.1 Symbols

2.1.1 On the device / name plate

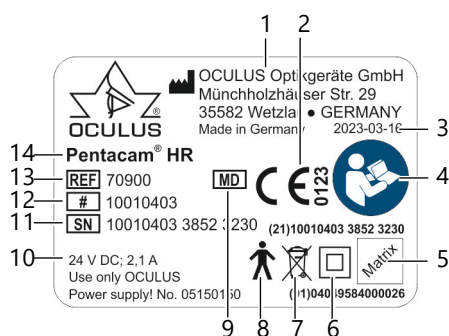









Fig. 2-1: Name plate (example)

No.	Description	No.	Description
1	Name and address of manufacturer	8	Applied part Type B
2	CE conformity and number of the notified body	9	Medical device
3	Date of manufacture	10	Power supply
4	Follow instruction for use	11	Serial number
5	UDI number (example), consisting of: UDI-DI (Device-Identification) UDI-PI (Product Identifier) and machine-readable matrix code	12	Model number
		13	Article number
		14	Device type
6	Safety class		
7	Disposal in household trash is prohibited		

2.1.2 On the packaging

Symbol	Description
	Keep dry
	This way up
	Fragile
Transport 	Limit of temperature for transport
Storage 	Limit of temperature for storage
	Limit of humidity
	Limit of air pressure

2.1.3 In this Manual



Warning

Identifies a potentially dangerous situation which may cause serious injury.



Caution

Identifies a potentially dangerous situation which may cause minor injury.



Attention

Identifies situations which may cause damage to the device or incorrect test results.



Indicates important instructions for use and important information about the device.

- > This symbol denotes menu paths and screen shots. Example for starting a new examination:
 Pentacam® / Pentacam® HR > Examination > Scan
 which means:
 - ➔ Select the "Examination" menu from the menu bar.
 - ➔ Select the menu item "Scan".
- [] Marks buttons.
- Cross reference

2.2 Safety Instructions for Use

Any serious-incident that has occurred in relation to the device should be reported to the manufacturer (vigilance@oculus.de) and the competent authority of the region in which the user and/or patient is established.



- ➔ Carefully read through the Instructions for Use.
- ➔ Keep the Instructions for Use in good condition near the device.
- ➔ Observe the legal regulations with regard to accident prevention.



Caution

Personal injury or property damage due to improper operation

- ➔ Observe the following safety instructions.



Caution

Personal injury or property damage due to equipment modifications that could jeopardize safety

- ➔ No modifications may be made to this device without the permission of the manufacturer. Only the OCULUS service and authorized dealers are allowed
 - to modify the device or the associated lifting table
 - to install software and software updates.

2.2.1 Patient environment information

Patient environment is the area where patients can come into contact with any part of a medical electrical equipment (ME equipment) or with another person being in contact with the ME equipment.

- ➔ Only use devices that are compliant with IEC 60601-1 in the patient environment.

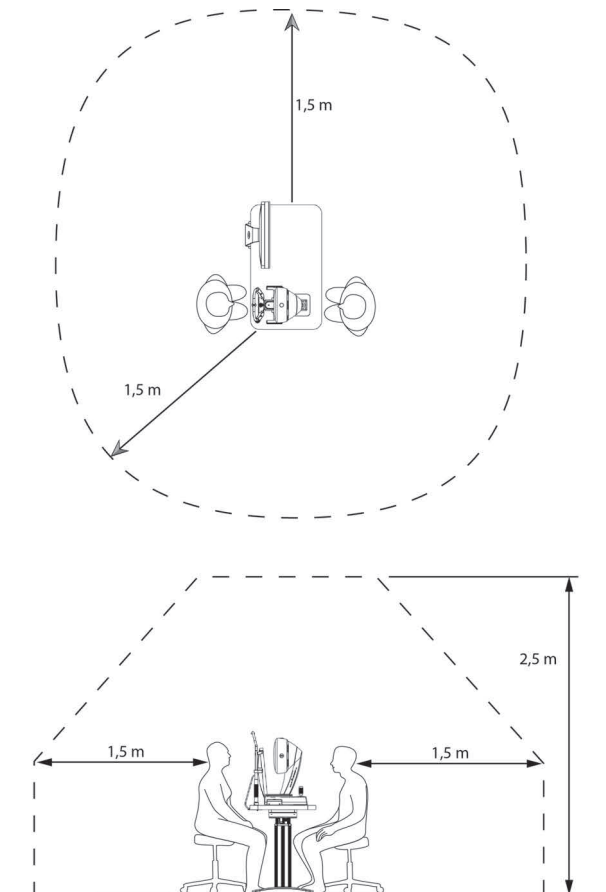

Fig. 2-2: Patient environment

2.2.2 Instructions for the operation of a ME system

The device and a connected computer form together a medical electrical system (ME system) according to IEC 60601-1. If you connect additional devices, such as, for example a printer, those devices become part of the ME system.

- ➔ All devices of the ME system must comply with the requirements of IEC 60601-1 or IEC 62368-1.

2.2.3 Instructions on Electrical Safety

Caution
Risk of personal injury or damage to property due to an incorrect level of safety

Connecting the Pentacam® / Pentacam® HR with its non-medical electrical equipment (e.g. data processing equipment) to a medical electrical system must not result in a patient safety level below that prescribed by IEC 60601-1. If making this connection leads to the leakage current threshold being exceeded, protective measures including a circuit breaker must be in place.

- Ensure that connections with non-medical devices are made correctly.
- Only use the power adapter listed in the packing list.
- Use only a computer that meets the specifications given in this Instructions for Use, → chap. 13 Technical Data, page 69.

Caution
Risk of personal injury or material damage caused by unsafe multiple socket extension cord

If you use a multiple socket extension cord to connect the device to the power supply, you must heed the following information:

- Use an extension cord that complies with the requirements of IEC 60601-1, section 16.
- Do not place the multiple socket extension cord on the floor.
- Do not use more than one multiple socket extension cord.
- Plug only the device and the computer that is being used with the unit (if applicable) into the multiple socket extension cord.
- If you are using a multiple socket extension chord it has to be supplied with a isolation transformer.
- If you are using a new computer for the device, you must have the electrical safety checked. Call OCULUS Service for this purpose.

Caution
Risk of personal injury or damage to property due to electromagnetic interference

Portable and mobile RF communications equipment can affect medical electrical equipment see chap. "14.1 Electromagnetic Compatibility" on page 71.

- Make sure that portable and mobile RF communications equipment do not cause interference.
- Recommendation: Maintain a minimum distance (refer "14.1 Electromagnetic Compatibility" on page 71). If the distance is shorter, you must ensure that the Pentacam® / Pentacam® HR functions correctly.

2.3 Instructions on Cyber Security



The device does not require a network or internet connection to work. The device itself was not designed to connect via a coupled computer to the internet or other network, or to portable media, as the device does not require a network or internet connection to function.

User who elect to connect the device coupled computer to the internet or other network for other purposes are responsible for ensuring that it is done so in a controlled manner.

2.3.1 Precautions for access control of the computer

To ensure cyber security when using the device:

➔ Secure the device against unauthorized access by unauthorized persons.

The following security measures should be considered:

- Secure the computer with a password (for example at Windows start up).
- Choose a complex password: A good password should be at least eight characters long and are not in the dictionary. In addition to letters, it should also include numbers and special characters.
- Do not choose a name or device name for a password (for example "Pentacam").
- Change the password regularly.
- Do not note the password in an accessible location.
- Use different passwords for different users.
- Enable the screen saver and use the option for the necessity of reentering the password when exit the screen saver.
- Choose an adequate time setting for starting the screen saver if software session is inactive (e.g. 10 minutes). Adequate time setting should consider duration of examination, number of patients, time between examinations, use of other devices in the examination room, several user, etc.
- Lock the computer if you are leaving the workstation (shortcut: 'windows logo key' + 'L').
- Contact your administrator if necessary.

2.3.2 User Responsibility

User names or passwords must not be shared with colleagues or others, even if they are permitted by law and provider policy to view the same type of information (e.g. two operators reviewing the same patient samples).

Operators have access to sensitive patient data (ePHI). No snapshots, screen shots or images (e.g. with another device) of information displayed via the device may be taken.

Operators should not enter any identifying data into the device. All the data on the device should be anonymized and refer to the sample ID and not to the patient.

2.3.3 Reporting Device Security or Privacy Breaches

Operators must contact their local IT department and disclose any suspected or confirmed compromised user accounts, and any other privacy or security breaches.

2.3.4 Recovering from Compromised Accounts or Devices

When accounts are considered compromised, devices are lost, or unauthorized access is discovered or suspected, the Healthcare Organization’s IT network administrators suspend and modify the user login criteria and issue new login credentials for the user to access their account securely.

2.3.5 Unavailable Service

Users should report unavailable service or prohibited access to information to their local Healthcare Organization’s IT department.

2.3.6 Precautions if the computer is connected to a LAN or internet network



Always use a wired connection to transfer examination data from the device to the PC.
Do not use wireless technologies.



Please observe the regulations, instructions and recommendations of your responsible Office for Information Security for the protection of critical infrastructures.

- Do not connect with the internet while using the device. It is considered misuse!
- If you elect to connect the computer to the internet for other purposes you are responsible for ensuring data security.

If you connect the computer to the LAN or internet, you are responsible for ensuring data security.

Observe therefore:

- Prefer wired connections of the computer to the network.
- If you are using Wi-Fi connections nevertheless, please ensure the usage of adequate security methods (for example WPA2/AES – Wi-Fi Protected Access / Advanced Encryption Standard – with a strong network key).
- The usage of a firewall (software or hardware) is recommended.
- Follow the instructions for integration into an IT network (see chap. “14.5 Instructions for integration into an IT-Network” on page 79).

3 Device Description

3.1 Overview of the device components

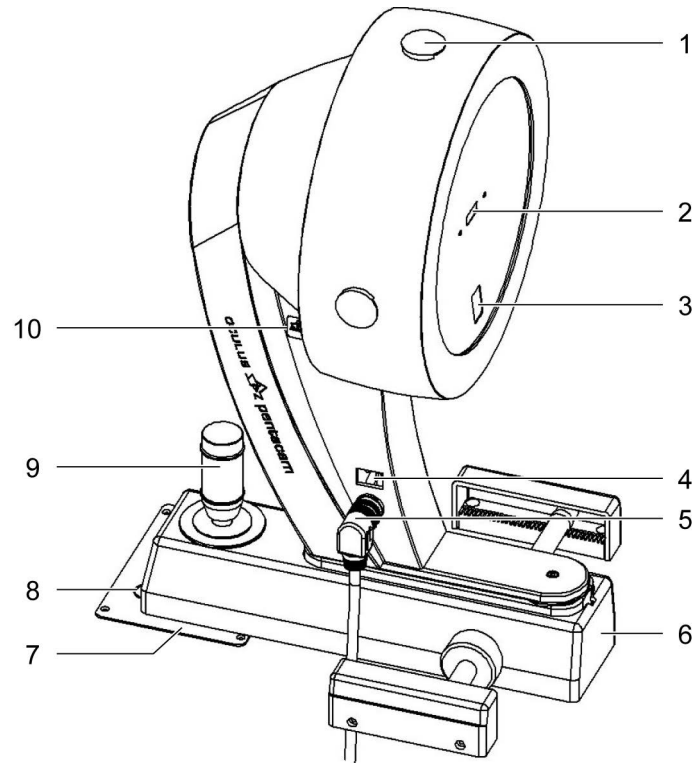

Fig. 3-1: Device components

No.	Description
1	Ventilation opening
2	Measuring window
3	Camera opening
4	On/off switch with indicator light
5	Y-cable connector
6	Cross slide
7	Sliding plate
8	Circular markings on sliding plate
9	Joystick
10	Nameplate

3.2 Applied parts

The chin and head rest are applied parts of type B.



Fig. 3-2: Anwendungsteile

No.	Description
1	Head rest
2	Chin rest

3.3 Functionality of the Pentacam® / Pentacam® HR

While rotating around the eye, the Pentacam® captures Scheimpflug images of the anterior eye segment through varying axes. The Scheimpflug images created during an examination are transmitted to the connected PC.

Up to 50 (Pentacam) or 100 (Pentacam HR) Scheimpflug images can be captured within maximum two seconds.

Up to 25,000 (HR: 138,000) genuine height values are measured and analysed from the Scheimpflug images.

The Scheimpflug images are the basis for the height data which are used to calculate a mathematical 3D model of the anterior eye segment. At same time any eye movements are recorded and taken into account.

A quality specification (QS) lets you gauge the quality of the measurement taken.

The mathematical 3D model, corrected for eye movements, provides the basis for all subsequent analysis.

The topography of the front and rear surfaces of the cornea and the pachymetry are calculated and displayed from limbus to limbus for the entire surface of the cornea.

An analysis of the anterior chamber provides the basis for calculating the chamber angle, chamber volume and chamber depth.

Densitometry of the cornea and lens automatically produces quantified values.

Colour images displayed on the screen show the results of the measurement.

A rotatable 3D model displays the front and rear surfaces of the cornea, the iris and the lens.

3.4 Intended Purpose



OCULUS Optikgeräte GmbH is not liable for the evaluation and interpretation of measurements taken with the Pentacam® / Pentacam® HR. The user manual and interpretation guide can provide assistance in this regard.



The device is intended exclusively for the use specified in this manual and in compliance with the safety instructions.



For the US-Market only: Federal law restricts this device to sale by or on the order of a physician, or with the descriptive designation of any other practitioner licensed by the law of the State in which he practices to use or order the use of this device.

3.5 Intended Use

The OCULUS Pentacam® / Pentacam® HR is designed to take photos of the anterior segment of the eye which includes the cornea, pupil, anterior chamber and lens of the eye to evaluate:

- corneal shape,
- analyse condition of the lens (opaque crystalline lens),
- analyse the anterior chamber angle,
- analyse anterior chamber depth,
- analyse the volume of the anterior chamber,
- analyse anterior or posterior cortical opacity,
- analyse the location of cataracts (nuclear, subcapsular and or cortical), using cross
- slit images with densitometry and
- corneal thickness.

3.5.1 Contraindication

None known.

3.5.2 Possible side effects

- After-image
- Headache
- Vertigo
- Tearing eyes

3.5.3 Intended users

The Pentacam® / Pentacam® HR is intended exclusively for use in:

- ophthalmology practices
- clinics
- opticians or optometrists

The Pentacam® / Pentacam® HR is intended for use by trained personnel:

- Who can ensure proper handling based on their knowledge, training and practical experience.
- Who have been instructed by OCULUS personnel or an authorized dealer prior to commissioning.

3.5.4 Patient group

- Children from 3 years up to not limited.
- No restrictions on weight.
- Patient is awake.
- Patient is able to understand and to look into a fixation target.

4 Setup and Installation

- Only OCULUS or an authorized dealer is allowed to set up and to connect the device.
- Do not use or store the device in rooms that are humid, see chap. "10 Transport and Storage" on page 65.
- Keep the device away from water that may drip, splash or spray on it, and make sure that no liquids can get into the device. Do not place any containers holding liquids in the vicinity of the Pentacam® / Pentacam® HR.
- Germany: Only operate the device in rooms used for medical purposes after they have been set up according to the VDE Regulation 0100-710.
- Do not operate the devices included in the delivery in areas where explosions may occur, or in proximity to flammable anesthetics or volatile substances such as alcohol, benzine or similar products.
- Set up the device so that the power plug is easy to access. That way, you can easily disconnect it from the power supply for any repairs or maintenance work.
- Do not force any plug connections.
If you are unable to make a plug connection, check whether the plug fits the socket.
If you detect damage to the connection, you should let authorized dealer repair the damage.
- Only use a device which is mounted at the lifting table properly.

4.1 Setup



Attention

Incorrect installation may result in incorrect measurements or even damage to the device.

- Have the device set up and connected by our service department or by a specialist authorized by OCULUS.
- Set up the device so that it cannot fall over. Mount the device on an examination table.
- Set up the device so that it is protected from dripping, splashing or spray water.



Attention

Damage to the device due to incorrect handling

- Do not expose the device to any vibrations, shocks, contaminants, moisture, or high temperatures.
- Handle the device with care.

- Set up the Pentacam® / Pentacam® HR so that the power plug is easy to access. That way, you can easily disconnect it from the power supply for any repairs or maintenance work.
- Place the device so that direct light cannot affect the measurement.
- Make sure the examination is free from light reflections. To achieve this, darken the examination room.

4.2 Installation and Operating Conditions

Temperature	+10 – +35 °C
Air humidity	30 – 90 %
Air pressure	800 – 1060 hPa

- Before installation, compare the transport and storage temperature with the temperature in the intended installation room.
- The difference between the transport and storage temperature and the installation room should not be more than 10°C to prevent the internal optics from misting up.

4.3 Electrical Connection



Caution

If there are temperature differences between the transport and storage temperature and the installation room, especially if the temperature exceeds 10°C, the optics may fog up and/or condensation may form.

- ➔ Leave the device unused in the installation room for at least 6 hours before connecting it so that the device can adjust to the ambient temperature.



Caution

Electrical safety hazard

- ➔ Do not use the device directly next to other devices.
- ➔ Do not stack the device with other devices.
- ➔ Only use the power supply unit supplied or one identical to the one specified in the Tech. Data (see chap. "13 Technical Data" on page 69).
- ➔ Do not place any heavy objects or the device itself on the power cable.
- ➔ If you use a multiple socket to connect the device, the multiple socket must comply with the requirements of IEC 60601-1.
- ➔ Do not place the power strip on the floor.
- ➔ Do not expose the mains cable or the multiple socket to high temperatures. Do not place on heaters!
- ➔ Use a maximum of one multiple socket.
- ➔ Only connect the device and, if applicable, the associated computer to this multiple socket.
- ➔ Use a socket outlet that has a faultless protective conductor connection.

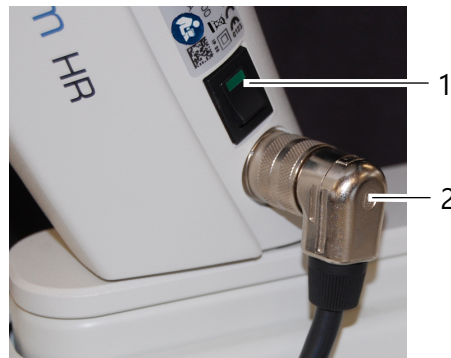

No.	Description
1	On / Off switch
2	Plug of the Y-cable

Fig. 4-1: Electrical Connection

**Attention**

If the device is not connected correctly and voltage is applied, the device may be damaged after a short time.

- Do not use excessive force to connect electrical connections.
- Observe the specifications on the name plate.
- If the plug is defective, contact OCULUS Service or an authorized dealer to repair the damage.

- Plug the connector of the Y-cable into the jack and tighten the connection. Make sure that the plug is inserted in the correct position.
- Firmly tighten the connection.
- Connect the Y-cable to the PC/laptop and the power adapter.

4.4 Switching On

**Caution**

Risk of incorrect measurements due to improper setup

- Before taking measurements, the device has to be switched on, at least for one hour.

1. The first step is to switch on the PC or laptop.
2. Then turn on the device with the on/off switch (position ON).
The LED on the switch lights up green, [fig. 4-1, page 24](#).

4.5 Switching Off

1. Close the Pentacam program and close the Patient Data Management.
2. Shut down the Windows operating system.
3. Turn the device off with the on/off switch (OFF position)

4.6 Software Installation on separate PCs

The Pentacam-Software is network compatible. This makes it possible to install the Pentacam[®] Software on several PCs, connected in a local network.

Make sure, that all PC in a network do have the same Pentacam[®] software version installed.

A Floating License Key is part of every Pentacam[®] shipment. Please ensure a proper installation based on the Manual for the Floating License Key.

This allows an interactive parallel evaluation of the Pentacam[®] exams based on the released optional software packages and modules.

The demo examinations included can be viewed on every computer having the Pentacam[®] software installed.

For more detailed information contact your authorized dealer or our service department.

5 Pentacam® Program

The device is safe to use if no error message is displayed after starting the software when the device is connected and switched on (e.g. component failure, camera not recognized, missing reference data, etc.).

After starting, the patient data management opens (see chap. "7 Patient Data Management" on page 52).



The Pentacam® program is not to be used to dictate therapy without professional correlation with other clinical findings and diagnostic tests.

5.1 Menu Bar in the Pentacam® Programm

To start the Pentacam® program from the patient data management click on the Pentacam® button.

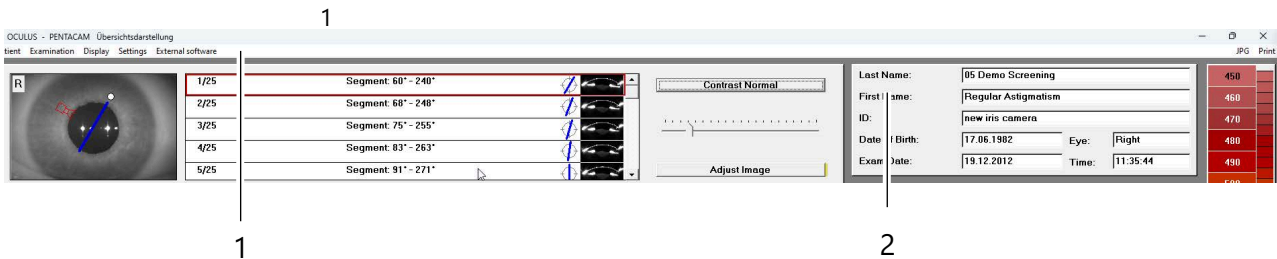

Fig. 5-1: Pentacam® program menu (upper section)

No.	Description
1	Menu bar
2	Examination and Patient data

5.2 Scan Screen

Open the Scan screen:

→ menu bar [Examination] > [Scan]

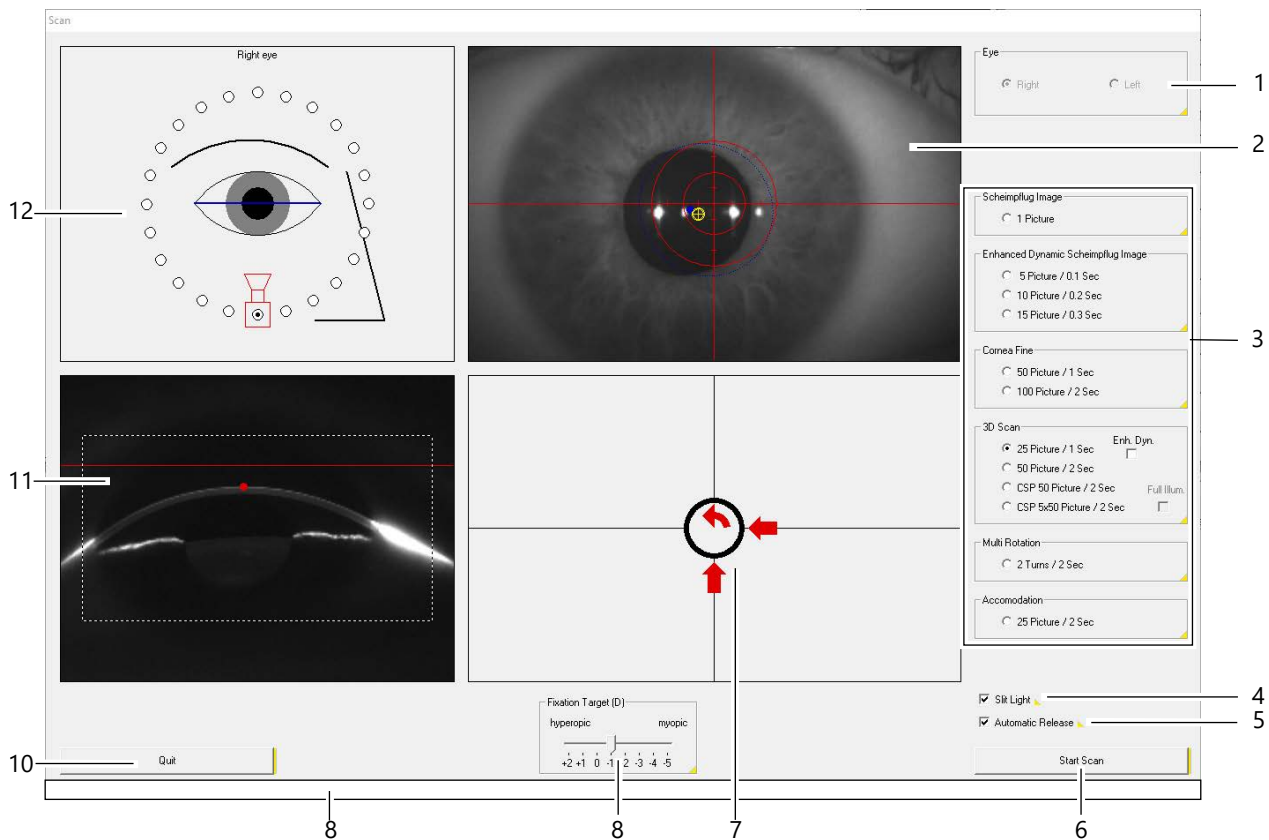

Fig. 5-2: "Scan" screen ("HR" model)

No.	Description	
1	"Eye" field	The eye currently being examined is detected automatically and displayed.
2	Front image / Pupil image	Shows the vertical / horizontal positioning of the Pentacam. The object is to position the yellow dot marking the apex of the cornea in the centre of the crosshairs. The blue dot marks the centre of the pupil, while the blue ring frames the pupil.
3	"Image Options" area	Set the type of image required for the respective examination (→ chap. 5.2.1 Scheimpflug image settings, page 28 and → chap. 5.2.2 Parameters applicable only to the Pentacam® HR, page 28)
4	[Slit Light] checkbox	Activate or deactivate the blue light for illuminating the eye.
5	[Automatic Release] checkbox	Activate automatic measurement.
6	[Start Scan] button	Activates manual measurement, when [Automatic Release] is deactivated. You can also use the Return key.
7	Adjustment window	The arrows show the direction in which you must move the device to activate automatic measurement (Automatic Release).
8	Fixation target	(only Pentacam® HR) (→ chap. 5.2.2 Parameters applicable only to the Pentacam® HR, page 28). Serves to improve fixation by means of slight correction adjustment.

No.	Description	
9	Message about device, if necessary	Shows messages about the device, for example if a service is due.
10	[Quit] button	Abort measurement.
11	Scheimpflug Image	Shows the distance between the device and the patient. The objective of this setting is to move the red dot on the front surface of the cornea so as to coincide with the red line
12	"Orientation" field	Shows the respective position of the camera and the eye, which is currently being examined.

5.2.1 Scheimpflug image settings

You can set the number and type of images required for the respective examination in the "Image Options" box (3).

"Scheimpflug Image" group box

- If you activate this option, the camera records only one Scheimpflug image. You can freely select the camera position you require by clicking the white rings in the "Orientation" field (11).

"Enhanced Dynamic Scheimpflug Image" group box

- Use this option to make the camera record either 5, 10 or 15 Scheimpflug images, with the camera remaining in the same position. Image averaging is carried out on the recorded images to minimise background noise. Only one Scheimpflug image is displayed. You can freely select the camera position you require by clicking the white rings in the "Orientation" field. This type of image is suitable for a purely densitometric assessment of the lens.

"3D Scan" group box

- Use this option to select how many images you want the camera to record per scan. The difference is in the duration of the examination and the number of measuring points that are evaluated. A scan comprising 50 images takes longer, of the patient provides the highest amount on measured elevation data. This type of examination is used for evaluating the cornea and anterior chamber.
- You can also select whether or not a CSP scan (Cornea scleral profile) should be recorded. A CSP scan measures both the cornea and the sclera profile, see also → chap. 6.5 Quality Specifications, page 36.

5.2.2 Parameters applicable only to the Pentacam® HR



Note

The parameters described below apply only to the Pentacam® HR.

The Pentacam® HR has additional options for selecting image types (see Scan Menu "Image Options" box (3)).

"Cornea Fine" group box

- Select this option for a more detailed image of the cornea.
 The camera does not capture the deeper-lying layers of the front part. You can select 50 Scheimpflug images for a recording time of one second, or 100 Scheimpflug images for a recording time of two seconds.

"Multi Rotation" group box

- If you select this option, the camera will record Scheimpflug images from 50 different positions while performing a full rotation twice around the eye.

"Accommodation" group box

- If you select this option, the camera will take a total of 50 Scheimpflug images. While the camera is recording the images, the "Fixation Target" shifts constantly from -5 D to +2 D. The camera records the Scheimpflug images from a pre-selected camera position.

[Enh. Dyn.] checkbox in the "3D Scan" group box

- Activating the "Enh. Dyn." function prolongs the exposure time per Scheimpflug image. The advantage is an clear representation of phakic IOLs. If you select this recording mode, colours and evaluations are neither calculated nor displayed.

"Fixation Target" slider

- Use of the "Fixation Target" enables a better fixation of the patient. For this, the active "Fixation Target" , for example the LED blinking red in the middle of the blue slit, can be shifted in steps of 0.5 D. The object is to offset defects in the patient's vision and ensure a simpler method of fixation.

5.3 Loading previous examinations

1. Select the menu item [Examination] and click [Load].
 The dialog box "Load Examination" appears.
2. Make a selection by clicking the required examination.
3. Confirm your selection by clicking [OK], or by double clicking.
 The Pentacam® program will load the examination you have selected.

5.4 Online help

Direct help can be accessed by clicking on a small yellow mark in the corners of buttons and fields.

Examples:

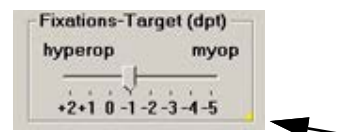

5.5 Information for recording Scheimpflug images

Type of examination	Examination mode	Images	Automatic measurement	Notes
Topography	3D scan	25-50	Yes	
Pachymetry	3D scan	25-50	Yes	
Analysis of the anterior chamber	3D scan	25-50	Yes	Do not apply mydriatic drops.
Artificial lenses (general)	Enhanced dynamic (for HR in the "3D scan" examination mode)	15	Yes	If the pupil is insufficiently dilated, apply mydriatic drops. Use 3D scan for measurements.
Measuring functions	3D scan	25-50	Yes	If the pupil is insufficiently dilated, apply mydriatic drops.
Densitometry	3D scan Enhanced dynamic	25-50 5-15	No	Use the same number of images to enable a progress check and apply mydriatic drops.

Specific instructions for the Pentacam® HR

Type of examination	Examination mode	Images	Automatic measurement	Notes
IOLs, ICLs, PIOLs	3D scan for PIOLs, possibly longer exposure	25-50	Yes	If the pupil is insufficiently dilated, apply mydriatic drops

6 Measuring Procedure



Attention

Risk of incorrect measurement due to incorrect use

- Before first use: Let OCULUS or an authorized dealer train you in the operation of the Pentacam® / Pentacam® HR.



Attention

Risk of incorrect measurements due to improper setup

- Before taking measurements, the Pentacam® / Pentacam® HR has to be switched on, at least for one hour.



Attention

Due to small movements of the patient or caused by a wheelchair, the patient is no longer positioned appropriately to the Pentacam® / Pentacam® HR, which can lead to incorrect measurements.

- Perform a Pentacam® / Pentacam® HR scan only if the patient sits in a stationary chair.
- In cases of wheel chairs lock the brakes.



The instructions for use focus on the operating concept of the Pentacam® / Pentacam® HR. The functional description of the Pentacam program is limited to initiating a measurement and loading existing examinations.

For detailed information about the features of the Pentacam program, see the user manual.

- Before first use: Let OCULUS or an authorized dealer train you in the operation of the device.
- Never operate a damaged device.
- Only operate the device with the original accessories supplied by us and only when the unit is in technically perfect condition.
- Do not cover the ventilation openings.
- Do not touch the patient and the device at the same time.
- Make sure that the device cannot tip over by leaning against it or sitting on it.
- Do not put the device, including rechargeable battery or cable, down onto devices that produce heat, heaters (for example radiators), microwaves or similar.
- Only operate the device if you have understood the operating instructions.



ISO 15004-2:2007 Group 2 instrument

A graph showing the relative spectral output of the instrument between 305 nm and 1100 nm when the instrument is operating at maximum light intensity and maximum aperture will be provided by OCULUS on request. The spectral output will be shown for the beam after it exits the instrument.



Caution

The light emitted from this instrument is potentially hazardous. The longer the duration of exposure, the greater is the risk of ocular damage. Exposure to light from this instrument when operated at maximum intensity will exceed the recommended maximum exposure (RME) of 2.2 J/cm^2 , unless additional action is taken by the user to minimize exposure, after 49 treatments (per patient eye).

The risk of retinal injury at an exposure of 2.2 J/cm^2 is not high, but because some patients may be more susceptible than others, caution is advised if this radiant exposure value is exceeded. However, because of a significant risk of injury at exposures exceeding 10 J/cm^2 , the user should avoid exposures longer than 225 treatments (per patient eye).

6.1 Default settings

1. Start the Scan menu in the Pentacam® Program:
Menu [Examination] > [Scan]
The blue slit light is activated and the Scan menu opens.
 2. If necessary make changes to the image options for the particular part of the front of the eye that is to be examined.
The default settings in the "3D Scan" options are "25 images/1 second".
 3. Adjust the table height.
 4. Check that
 - fresh paper has been put onto the chin rest or
 - the chin rest has been cleaned and disinfected.
 5. Ask the patient to place his or her head on the chin and forehead rest.
- Do not touch the patient and the Pentacam® / Pentacam® HR simultaneously.

6.2 Darken the room

6. Dim the lights in the room.
- If the lighting in the examination room cannot not be dimmed or switched off, use the dark sheet supplied to cover the patient and the device.



Fig. 6-1: Proband und Gerät mit Abdecktuch

6.3 Rough adjustment

7. Adjust the chin rest so that the patient's eyes are approximately at the level of the black ring on the chin-forehead rest.



Fig. 6-2: Rough adjustment of the chin and forehead rest

No.	Description
1	Black ring for eye level orientation
2	Twist grip for adjusting the height of the chin rest

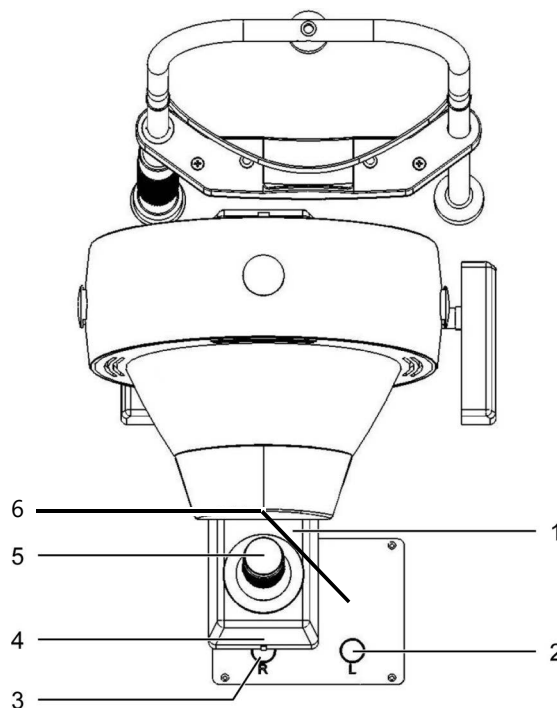

No.	Description
1	Cross slide
2	Left marking
3	Right marking
4	Marking on the cross slide
5	Joystick
6	Sliding plate

Fig. 6-3: Markings on the cross slide

8. Adjust the patient's eye level using the twist grip.
The patient is positioned correctly when chin and forehead touch the rests and the eyes are level with the marking.
9. Move the cross slide (example for the right eye) until the marking at the end of the cross slide roughly coincides with the circle R on the sliding plate.
10. Look at the patient's eye you are examining from one side and make sure that the blue slit light illuminates the cornea.
11. If necessary, adjust the position of the cross slide to the left or right.

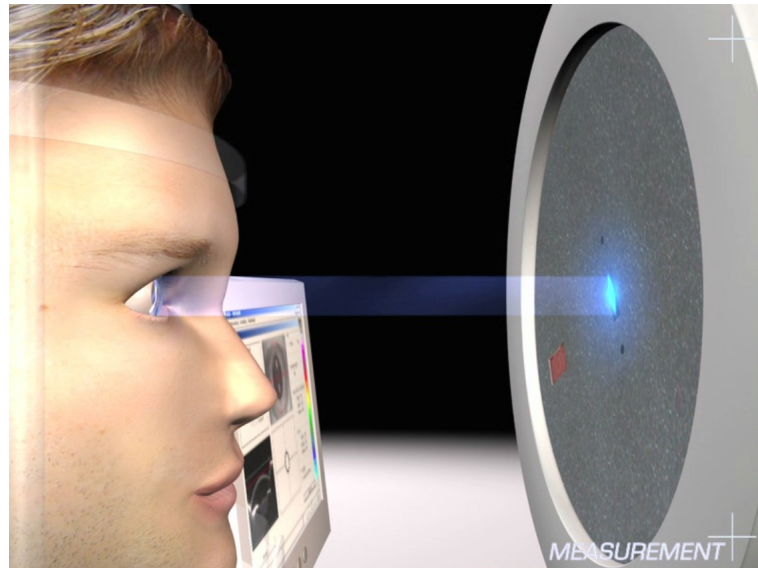

Fig. 6-4: Slit light on the cornea



Note

If the blue slit light is not visible, ensure that you have activated the [Slit Light] checkbox on the "Scan" screen.

6.4 Fine Adjustment

12. Configure the settings for the desired measurement on the scan screen → chap. 5.2 Scan Screen, page 27.
13. Move the cross slide towards the patient until the Scheimpflug image shows the cornea of the eye that you are examining.

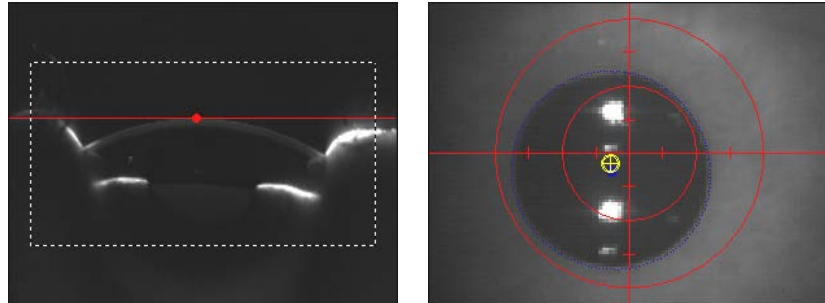

Fig. 6-5: Scheimpflug image (left) and pupil image (right)

The image is sharpest when the red dot coincides with the red line in the Scheimpflug image.

14. Focus the pupil image by moving the joystick towards the Pentacam® or away from it.
15. Adjust the left/right position of the Pentacam® and its height setting. Move the joystick to the left or right and rotate the joystick clockwise or anticlockwise. The tentative final position of the camera is reached when the yellow dot is in the centre of the crosshairs.
16. Ask the patient to blink again, then open their eyes wide and stop blinking.
17. Move or turn the joystick in the direction shown for fine adjustment.



Arrow	Camera movement	Joystick movement ^a
	right	Move the joystick to the right
	left	Move the joystick to the left
	forward	Move the joystick toward the patient
	back	Move the joystick away from the patient
	up	Rotate the joystick clockwise
	down	Rotate the joystick counter-clockwise

^a

- 18. When you have achieved the expected position, a cross will appear in the centre of the ring, surrounded by four lines. The Pentacam® will automatically begin measuring, alternately you can start the measuring procedure manually.
- ➔ For measuring manually: Start measuring by clicking [Start Scan] or by pressing the return key.



It may not be possible to carry out a measurement with manual release.

- ➔ Ask the patient to remove his or her head from the rest.
- ➔ Check the measurement results by referring to the quality specifications (➔ chap. 8 Cleaning, Disinfection and Maintenance, page 59).

6.5 Quality Specifications

After you have begun measuring either automatically or manually, the Pentacam® program opens. The "QS" button appears in a field below the patient data.

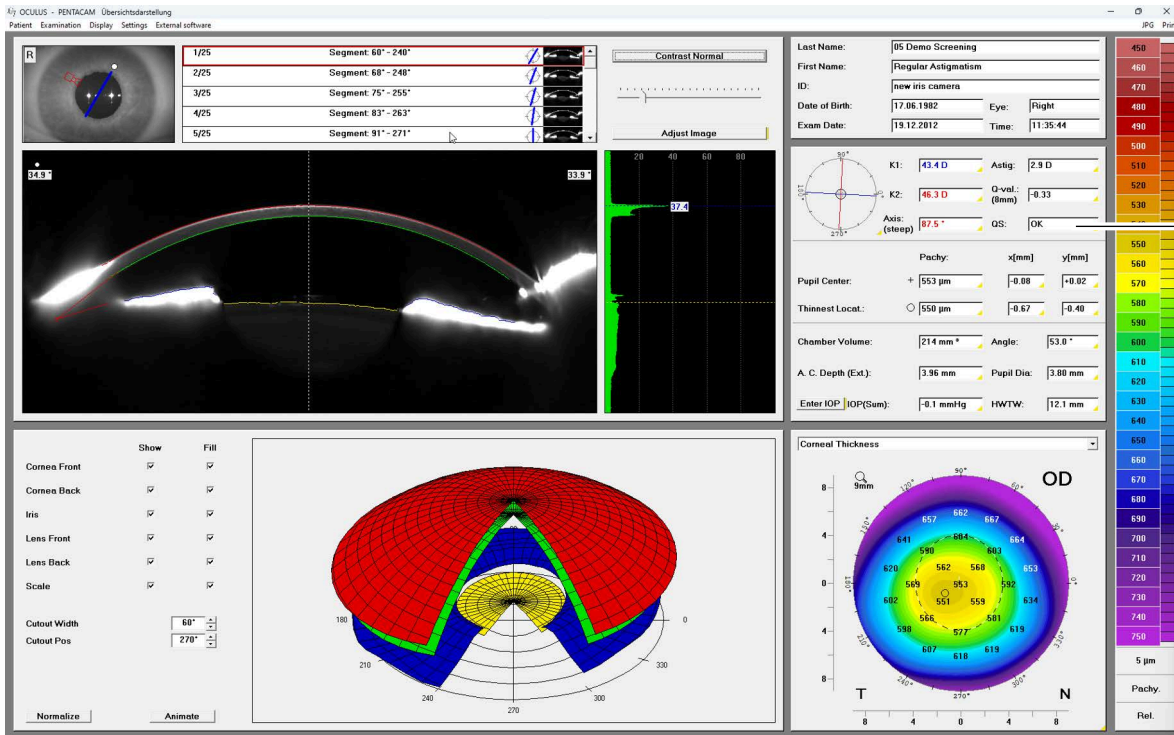

Fig. 6-6: Pentacam® program with "QS" field (1)

QS field	Meaning
OK	Measurement is correct and can be reproduced.
red	Repeat measurement.
yellow	Measurement not optimal: Check measurement results! Click on field.



All examinations are automatically saved, regardless of the quality of the measurement taken.

The dialog box shown appears:

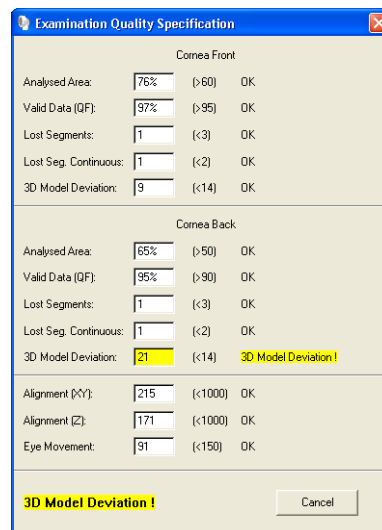

Fig. 6-7: Examination Quality Specification

QS Parameter	If an error occurs here, ...
Analysed Area	<p>... the measured area of the cornea is too small.</p> <p>→ The patient must open their eye wider. If necessary, assist the patient by holding their upper eyelid.</p>
Valid Data	<p>... no continuous data points could be determined in the Scheimpflug images, which can sometimes be the case with irregular or very cloudy corneas. In such cases, even repeated measurements will yield values highlighted in yellow at most. Or an ambient light source interfered with the recording.</p> <p>→ Completely darken the room..</p>
Lost Segments Lost Seg. Continuous	<p>... the patient blinked or the shadow cast by the nose is too large.</p> <p>→ Before the measurement process begins, the patient should blink again and then, without blinking, focus on the red LED or black ring on the device during the measurement process.</p> <p>→ If the error was caused by the nose covering the camera line, you must slightly turn the patient's head so that the nose is positioned away from the camera..</p>

QS Parameter	If an error occurs here, ...
Alignment (XY) and Alignment (Z)	<p>... the device was moved during the measurement trigger..</p> <p>→ Repeat the measurement.</p>
Eye Movement	<p>... the patient has not focused correctly on the target.</p> <p>→ Before the measurement process begins, the patient should blink once more and then, without blinking, focus on the red LED or black ring on the device during the measurement process.</p>
CSP Fixation	<p>→ If this value exceeds the limit, the measurement must be repeated. If necessary, explain to the patient that they must focus on the black ring.</p>

Terminating the evaluation of "QS"

- Click [Cancel] to return to the Pentacam® program.
- If required, delete the measurement if the image is inadequate.
- Terminate the current examination which has been saved.
- If required, make preparations to examine another patient. In the "Pentacam" overview, select the "Examination" menu and click [New Patient/End].

6.6 Measuring Procedure for Tomography

1. Prepare the measurement and adjust the patient, → chap. 6.1 Default settings, page 32.

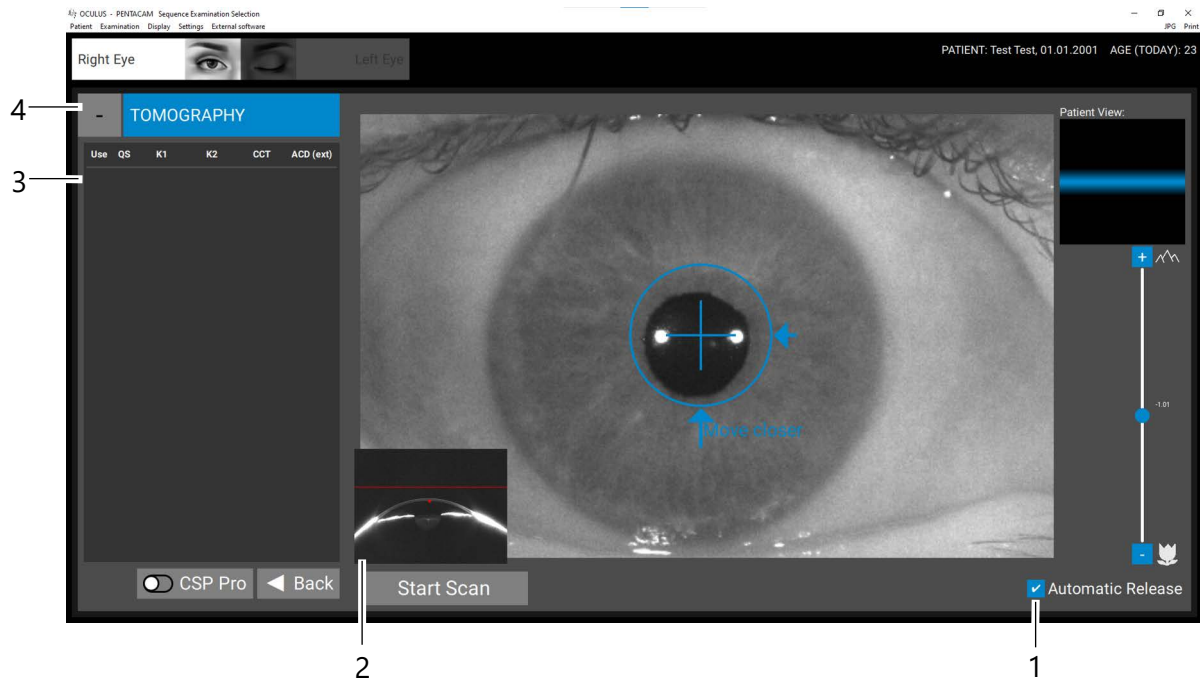

Fig. 6-8: Scan screen "Tomography"

No.	Description	
1	[Automatic Release] checkbox	
2	Live Scheimpflug image	
3	Tomography parameter	<ul style="list-style-type: none"> ■ Use: Examination can be used for the evaluation. Click the checkbox of the respective measurement to use it for the evaluation. Use only one measurement for the full sequence examination. ■ QS: Quality specifications, see → chap. 6.6.1 Quality Specifications for the Tomography, page 41 ■ K1: Flat radius of the corneal curvature ■ K2: Steep radius of the corneal curvature ■ CCT: Central corneal thickness ■ ACD: Anterior chamber depth
4	Current examination mode	

2. Move the cross slide towards the patient until the live Scheimpflug image shows the cornea of the eye that you are examining.

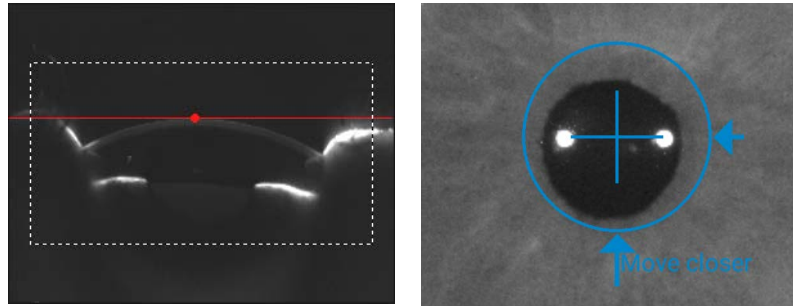

Fig. 6-9: Scheimpflug image (left) and overview image (right)

The image is sharpest when the red dot coincides with the red line in the Scheimpflug image.

3. Focus the pupil image by moving the joystick back and forth.
 4. Ask the patient to widen his or her eye and not to blink.
 5. Follow the instructions on the scan screen and adjust the left/right position of the Pentacam® / Pentacam® HR and its height setting.
Move the joystick to the left or right and rotate the joystick clockwise or anticlockwise.
The tentative final position of the camera is reached when the four bars frame the blue circle.
The Pentacam® / Pentacam® HR triggers the measurement automatically.
 6. Ask the patient to remove his or her head from the rest.
- Check the measurement results by referring to the quality specifications (→ [chap. 6.6.1 Quality Specifications for the Tomography, page 41](#)).

6.6.1 Quality Specifications for the Tomography

After measuring either automatically or manually, the Pentacam® program opens. The "QS" value appears in field (1).

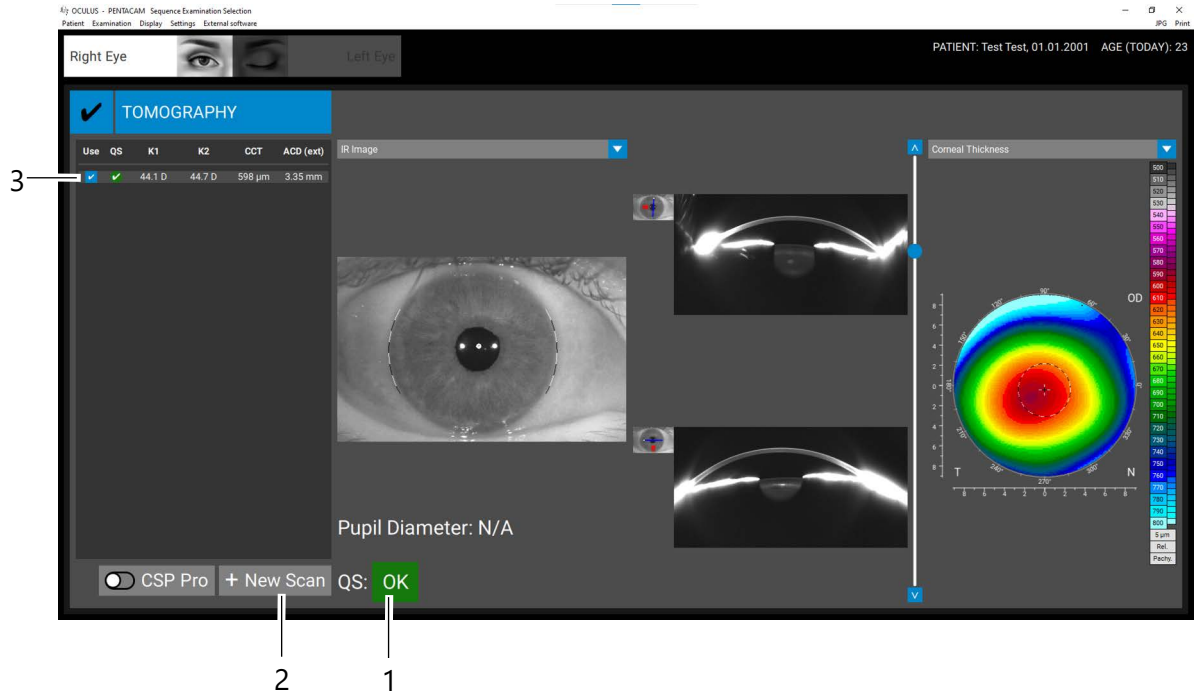

Fig. 6-10: Pentacam® / Pentacam® HR program with "QS" display

No.	Description
1	"QS" value
2	[+New Scan] button
3	[Use] checkbox



Note

All examinations are automatically saved, regardless of the quality of the measurement taken.

QS field	Meaning
OK	Measurement is correct and can be reproduced.
red	Repeat measurement.
yellow	Measurement not optimal: Check measurement results! Click on field.



If the "QS" display is highlighted in yellow or red, check the QS values.

1. Click the "QS" button.
The following dialog box appears:

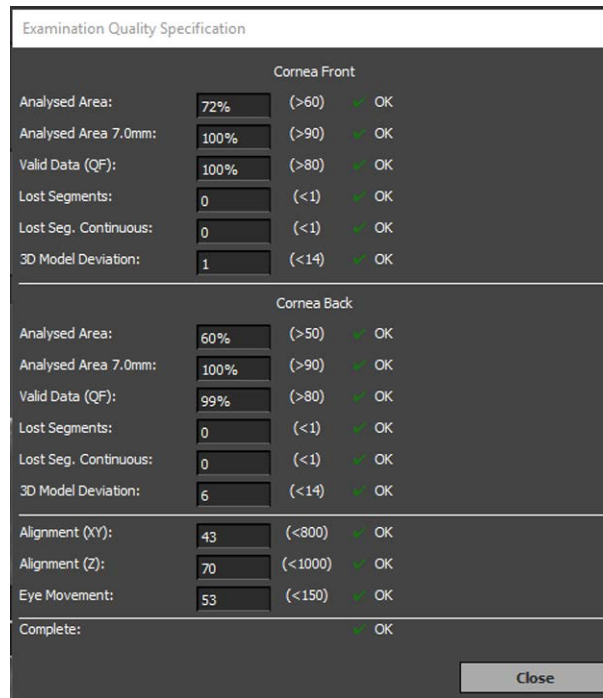

Fig. 6-11: Examination Quality Specification

2. Check the measurement results.
3. If you have any doubts, repeat the measurement.

QS Parameter	If an error occurs here, ...
Analysed Area	<p>... the measured area of the cornea is too small.</p> <p>➔ The patient must open their eye wider. If necessary, assist the patient by holding their upper eyelid.</p>
Valid Data	<p>... no continuous data points could be determined in the Scheimpflug images, which can sometimes be the case with irregular or very cloudy corneas. In such cases, even repeated measurements will yield values highlighted in yellow at most. Or an ambient light source interfered with the recording.</p> <p>➔ Completely darken the room..</p>
Lost Segments Lost Seg. Continuous	<p>... the patient blinked or the shadow cast by the nose is too large.</p> <p>➔ Before the measurement process begins, the patient should blink again and then, without blinking, focus on the red LED or black ring on the device during the measurement process.</p> <p>➔ If the error was caused by the nose covering the camera line, you must slightly turn the patient's head so that the nose is positioned away from the camera..</p>
Alignment (XY) and Alignment (Z)	<p>... the device was moved during the measurement trigger..</p> <p>➔ Repeat the measurement.</p>

QS Parameter	If an error occurs here, ...
Eye Movement	<p>... the patient has not focused correctly on the target.</p> <ul style="list-style-type: none"> ➔ Before the measurement process begins, the patient should blink once more and then, without blinking, focus on the red LED or black ring on the device during the measurement process.

Terminating the evaluation of "QS"

- ➔ If required, delete the measurement if the image is inadequate.
- ➔ If required, click the [+New Scan] button (2) for a new measurement.
- ➔ Click [Close] to return to the Pentacam® program.

6.7 CSP measurement (Pentacam® only)



In a CSP measurement, not only the cornea, but also the scleral profile is recorded. This ensures better accommodation of scleral lens. You can select the following CSP measurement:

- CSP 50 Picture / 2 seconds: 1 measurement – central scan
- CSP 5x50 Picture / 2 seconds: 1 measurement – central scan, 4 peripheral measurements - non-central scan, decentralized nasal scan, decentralized temporal scan, decentralized superior scan, decentralized inferior scan.
- ➔ For the first central scan, proceed as described in → [chap. 6 Measuring Procedure, page 31](#). After the first measurement, the following screen is displayed.

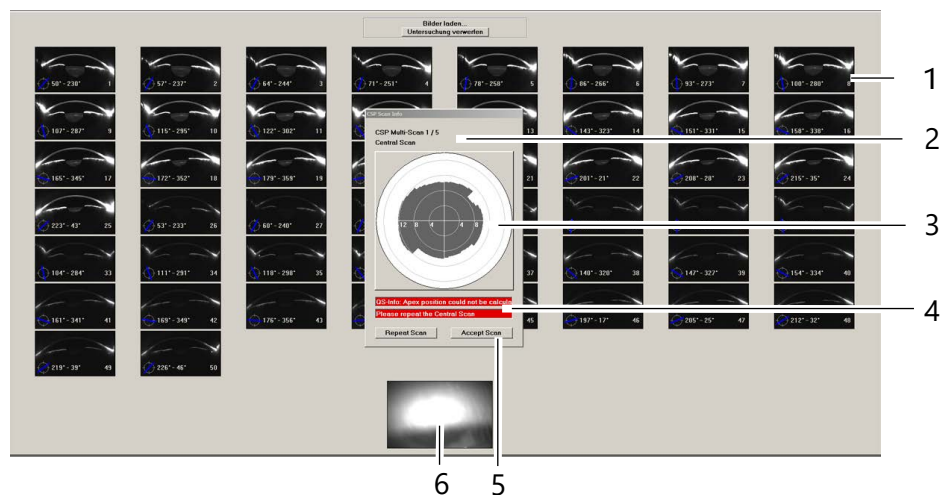

Fig. 6-12: CSP display (central scan)

No.	Description	No.	Description
1	Single Scheimpflug image	4	QS information
2	CSP scan information	5	[Accept Scan] and [Repeat Scan] button
3	Coverage card: central area	6	Iris image

The quality of the image is displayed in the 'QS Info' field (4). If the message 'Central Scan Successful' is displayed, the measurement is proper and repeatable.

- ➔ Click the [Accept Scan] button (5) if you are satisfied with the measurement. If necessary, you will be redirected to the peripheral measurements.

You can repeat the measurement if you are not satisfied with it.

→ Click on the [Repeat Scan] button (5).

The measurement is repeated. Old and new measurements are now compared, so the better of the two can be selected.

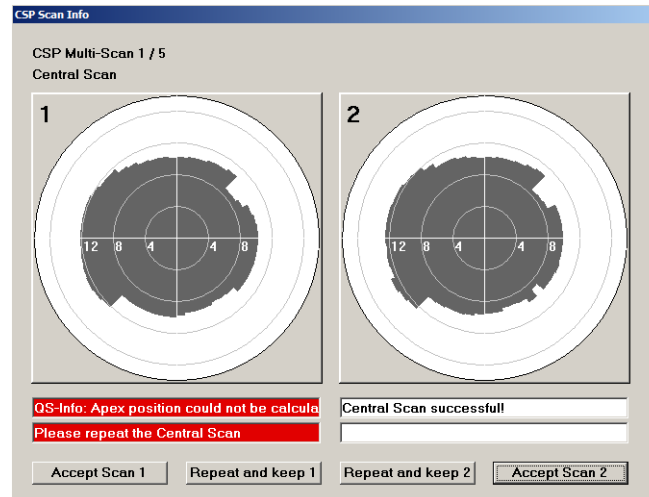

Fig. 6-13: Old and new measurement

The measurement can be repeated as needed.

If you are satisfied with one measurement, you will be automatically redirected to the next peripheral measurement.

→ Click on the [Accept Scan] button.

Peripheral measurements

Depending on the selected measurement mode, you will be automatically prompted to perform peripheral measurements after successful central scan. The measurement process generally remains the same for peripheral measurements. To find out which of the scans is currently being carried out refer to „CSP Scan Info“.



In order to achieve a good coverage of the cornea and sclera, it is important to keep the eye opened wide so that the required measured area is not covered by the eyelids.

We recommend to hold back the upper eyelid with the LidStick®. The patient can hold back the bottom eyelid with a finger. For a nasal scan, for example, it is important that the upper and bottom eyelids are also caught and held open nasally.

You can repeat measurements after every scan operation.

The extra area measured is displayed in colour in the Scan information. A diameter of approx. 16 mm is considered good coverage. After each additional peripheral scan, the coverage card is built up by one further segment, until a complete cornea scleral profile develops:

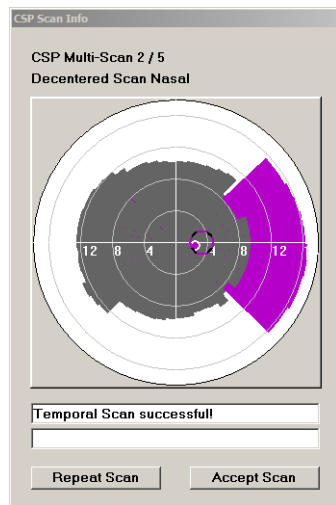

Nasal scan

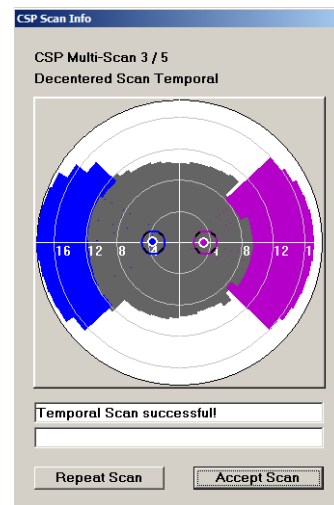

Temporal scan

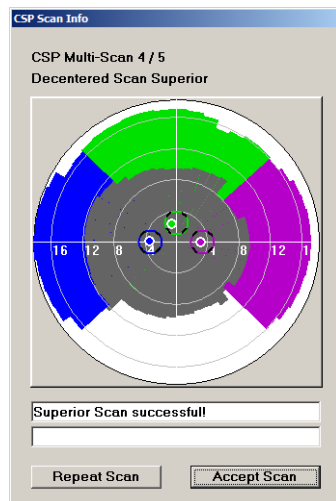

Superior scan

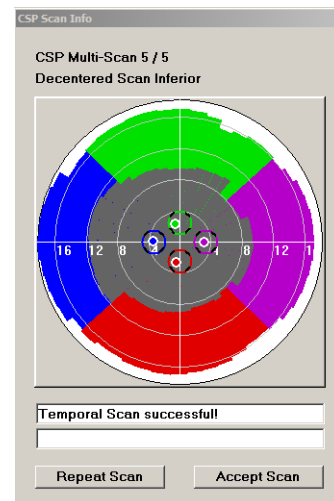

Inferior scan

Fig. 6-14: Coverage cards

6.8 CSP Pro measurement (Pentacam® HR only)

In a CSP Pro measurement, not only the cornea, but also parts of the sclera are measured. This means larger diameter contact lenses such as scleral lenses can be fitted.

Before the measurement

By default, always a tomography measurement is carried out (→ chap. 6.6 Measuring Procedure for Tomography, page 39). To carry out a CSP Pro measurement, proceed as follows:

1. Move the CSP Pro slider (3) to the right position to activate the CSP Pro measurement.
The "Tomography" entry is hidden and the "CSP Pro" entry is displayed instead.
2. Make sure that the [Automatic Release] checkbox (1) is selected.
3. Prepare the measurement and adjust the patient, → chap. 6.1 Default settings, page 32.

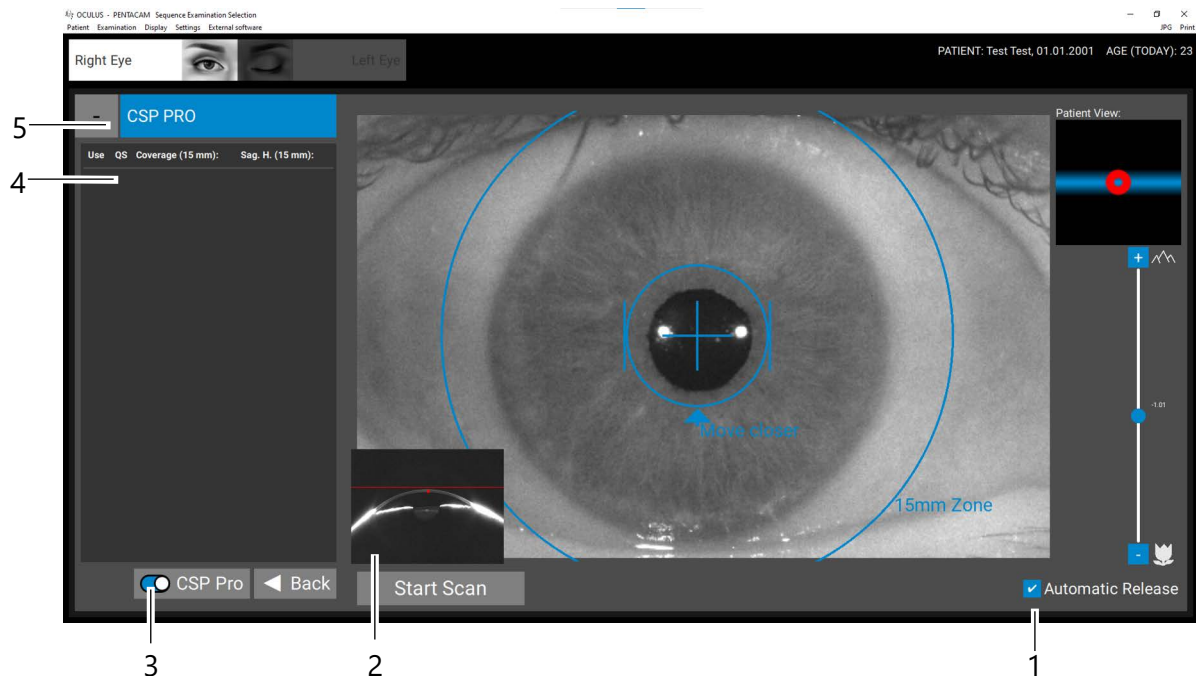

Fig. 6-15: "CSP Pro" examination screen

No.	Description
1	[Automatic Release] checkbox
2	Live Scheimpflug image
3	CSP Pro slider
4	Tomography parameter
5	Current examination mode

Perform measurement

4. Move the cross slide towards the patient until the live Scheimpflug image shows the cornea of the eye that you are examining

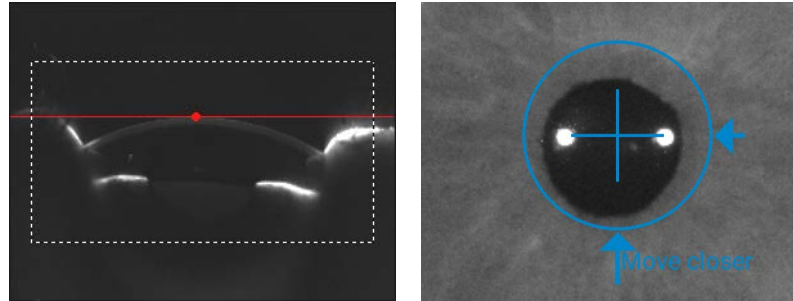

Fig. 6-16: Scheimpflug image (left) and overview image (right)

The image is sharpest when the red dot coincides with the red line in the Scheimpflug image.

5. Focus the pupil image by moving the joystick back and forth.
6. Ask the patient to widen his or her eye and not to blink.
7. Follow the instructions on the scan screen and adjust the left/right position of the Pentacam® / Pentacam® HR and its height setting.
Move the joystick to the left or right and rotate the joystick clockwise or anticlockwise.
The tentative final position of the camera is reached when the four bars frame the blue circle.
The Pentacam® / Pentacam® HR triggers the measurement automatically.
8. Ask the patient to remove his or her head from the rest.
9. Check the measurement results by referring to the quality specifications (→ [chap. 6.8.1 Quality specification for CSP Pro Measurement, page 48](#)).

6.8.1 Quality specification for CSP Pro Measurement

After measuring either automatically or manually, the Pentacam® program opens. The "QS" value appears in a field.



Fig. 6-17: Results display for a CSP Pro measurement

No.	Description
1	[+New Scan] button
2	"QS" value green / OK = measurement is correct and can be reproduced yellow = measurement not optimal; ideally repeat measurement red = no usable measurement; repeat the measurement
3	Value for the overall coverage
4	Display sum of all individual measurements
5	Individual measurements
6	[Add measurement] button
7	[Repeat measurement] button



Note

All examinations are automatically saved, regardless of the quality of the measurement taken.

If an error message is displayed in the "QS" field, the measurement must be repeated.

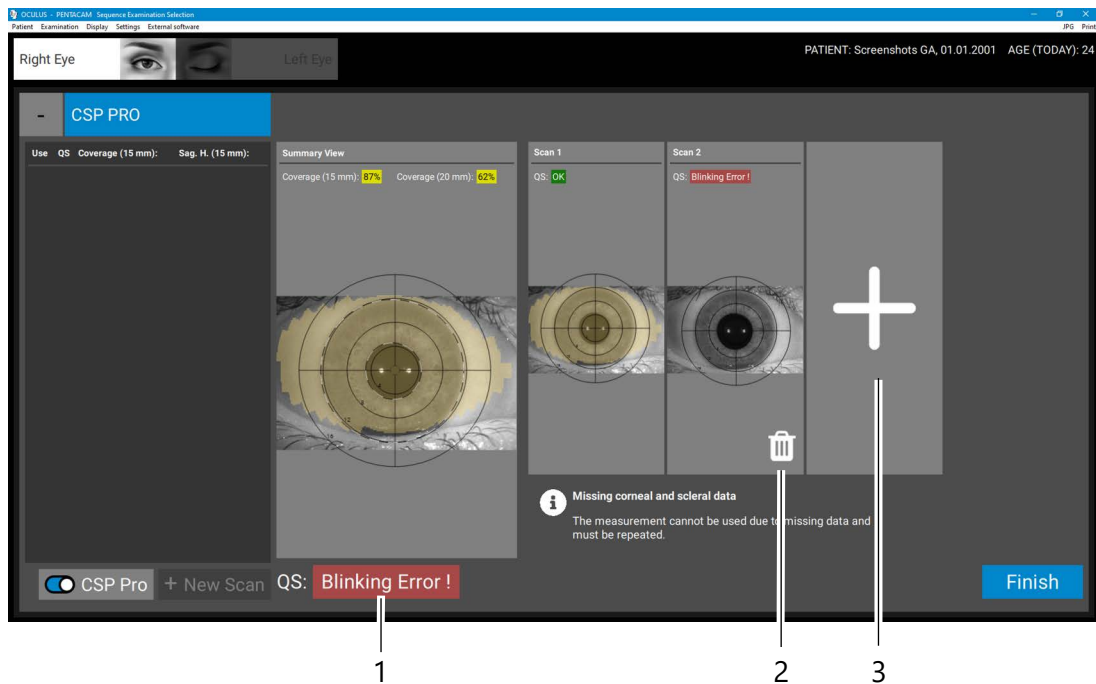

Fig. 6-18: Error message after a CSP Pro measurement

No.	Description
1	Error message
2	Button [🗑️] = Delete measurement
3	Button [➕] = Add measurement

6.8.2 Repeat or delete measurement

If the QS value of the first measurement is not sufficient to use this for evaluation, repeat the measurement:

1. Click on the [Repeat measurement] button.
The measurement is repeated and the previous measured values automatically get deleted.



The eye needs to be held open wide enough for the desired measurement area not to be covered by the eyelids to achieve good coverage of the cornea and sclera. We recommend holding up the upper eyelid with the LidStick® or alternatively a long cotton swab. The patient can carefully pull down his or her lower eyelid with a finger.

2. Click the [Add measurement] button to the right of the last measurement taken to add a measurement.
The coverage area of each measurement is shown in a different color in the corresponding display.
3. Carry out additional examinations until the required measurement area is achieved i.e. a complete corneal scleral profile.

4. If necessary, delete measurements with yellow or red QS. This is also necessary if more than 4 individual measurements have to be carried out in order to obtain coverage > 95%.

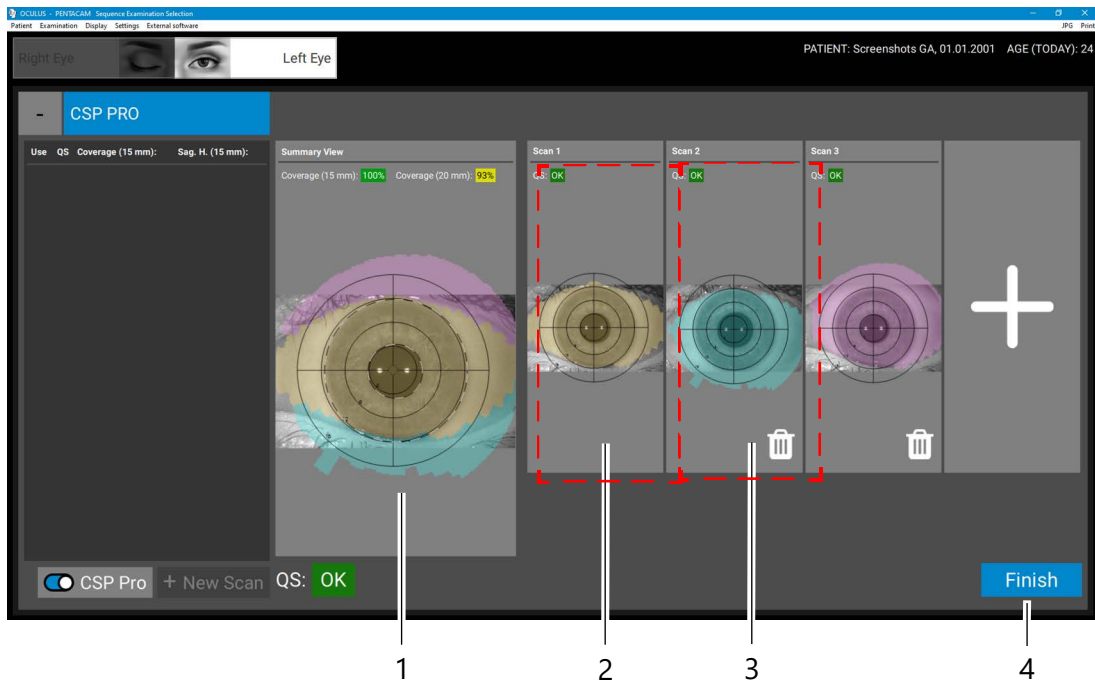

Fig. 6-19: Coverages of individual measurements and total coverage

No.	Description
1	Coverage areas of the single measurements Scan 1 and Scan 2 superimposed
2	Single measurement scan 1
3	Single measurement scan 2
4	[Finish] button

5. Click the [Finish] button to complete the CSP Pro measurement.

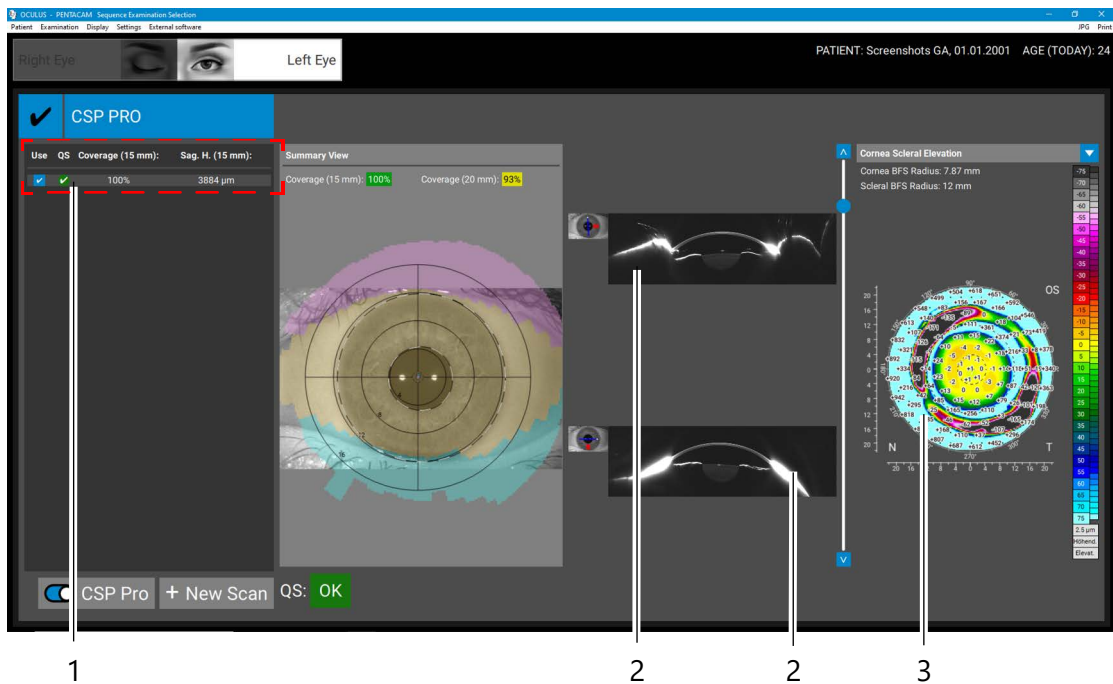

Fig. 6-20: Completed CSP Pro measurement

No.	Description	
1	Parameters of the CSP Pro measurement	<ul style="list-style-type: none"> ■ Use: Examination can be used for the evaluation. Click the checkbox of the respective measurement to use it for the evaluation. ■ Use only one measurement for the full sequence examination. ■ QS: Quality specifications, see → chap. 6.8.1 Quality specification for CSP Pro Measurement, page 48. ■ Coverage(15 mm): Coverage of the cornea and sclera in percent. ■ Sag. H. (15 mm): Sagittal height of the cornea for a diameter of 15 mm.
2	Scheimpflug images	
3	Elevation map	

7 Patient Data Management

Once you have completed an examination, you can do the following with the patient data:

- Rename it
(chap. "7.5 Rename Patient Data" on page 54)
- Export it
(chap. "7.6 Exporting Patient Data" on page 54)
- Import it
(chap. "7.7 Importing Patient Data" on page 56)
- Backup
(chap. "7.8 Data Backup" on page 57)



For more information on Patient Data Management, refer to the [User Guide](#).

7.1 Starting Patient Data Management

After you have switched on the PC, it first loads the operating system.

1. Press on the Pentacam® icon at the desktop.

The user interface for the Patient Data Management appears:

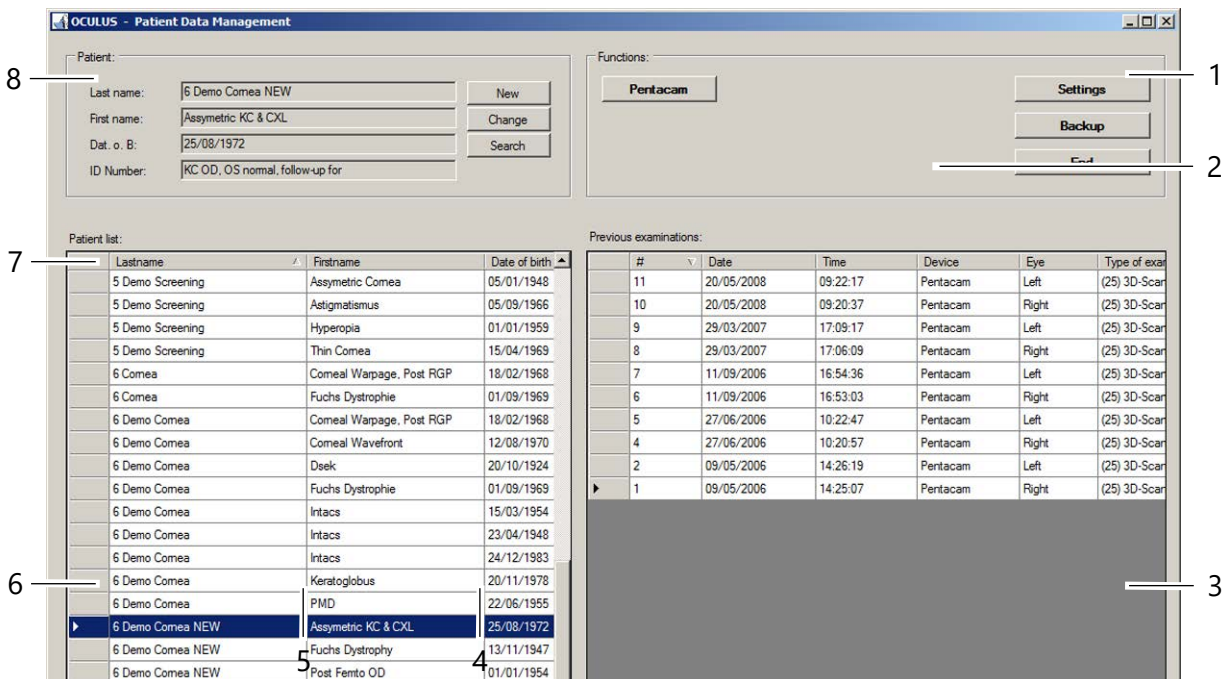

Fig. 7-1: Patient Data Management user interface

No.	Description
1	"Functions" group box
2	Previous examinations
3	[Delete exam.] button
4	[Delete Patient] button

No.	Description
5	[Export] button
6	[Import] button
7	Patient list
8	Patient data group box



To get into the Pentacam® / Pentacam® HR program, you must first enter a new patient (8) or select an existing patient from the examination list (2).

7.2 Entering a New Patient

1. Press the [New] button to enter a new patient in the Patient Data Management system.
2. Enter the patient's last name, first name and date of birth in the patient window.

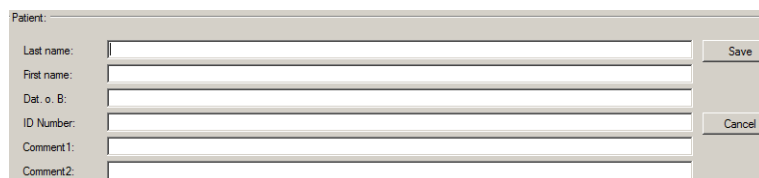
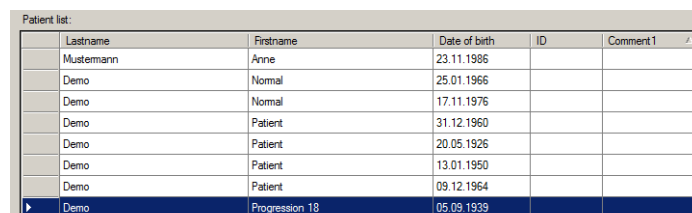

Fig. 7-2: Entering patients

3. Optionally you can enter an ID number for the patient.
3. To save your entries use the [Save] button.
The patient you have just entered now appears in the patient list and is automatically selected..

7.3 Selecting an Existing Patient

The patient data list on the left-hand side of the screen displays all previously examined patients in alphabetical order.



Lastname	Firstname	Date of birth	ID	Comment 1
Mustermann	Anne	23.11.1986		
Demo	Normal	25.01.1966		
Demo	Normal	17.11.1976		
Demo	Patient	31.12.1960		
Demo	Patient	20.05.1926		
Demo	Patient	13.01.1950		
Demo	Patient	09.12.1964		
Demo	Progression 18	05.09.1939		

Fig. 7-3: Patient list

1. Choose [Search] to quickly find the patient you are looking for in the list.
2. Enter the patient's name or the first letter of the name in the "Last name" field.
3. Alternatively, you can search for the patient using an ID number, first name or date of birth, assuming that one was assigned when the patient was first recorded.
4. In the list that appears, click the entry you were searching for to transfer the patient's name to the patient window. This also brings up a list of any previous examinations for that patient in the examination window (bottom right side).

7.4 Extended Patient Search: [Extended] Checkbox

➔ Click on the [Extended] checkbox.

The screen displays additional search parameters which reference previous examinations. Proceed as for the input of a patient name.

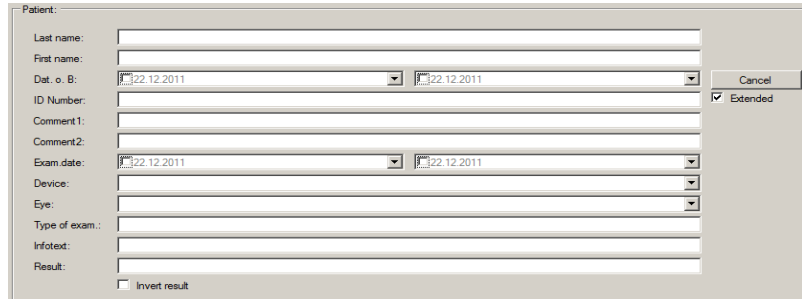

Fig. 7-4: Advanced search

7.5 Rename Patient Data

After creating of the patient data, you can edit it.

1. Press the [Change] button.
The input boxes for patient data are now enabled, and the cursor jumps to the "Last name" field.
2. Change the entries in the individual boxes.
3. Press the [Save] button.

7.6 Exporting Patient Data

Patient and examination data can be exported, for example, for forwarding to another clinic.

1. Select the patient and also one of the examinations in the respective list as required.
2. Click [Export] button below the patient list. The following dialog appears:

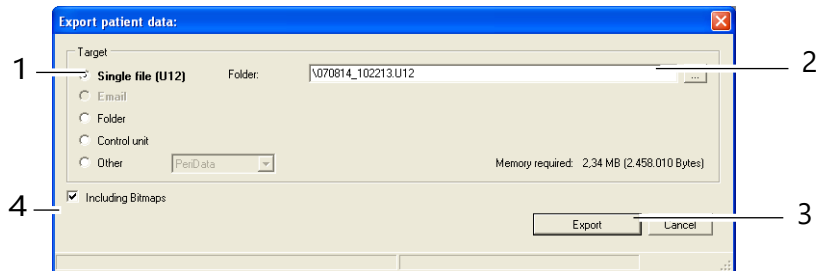

Fig. 7-5: "Export patient data" dialog

No.	Description
1	Saving destination selection
2	[...] button
3	[Cancel] and [Export] buttons
4	Options for data export



The default options for import and export of data are configured in the "Settings" field, see also the [User Guide](#). Depending on the settings, you may not have to perform all of the following steps (e.g. selection of the directory).

3. Select the "Target" (1) where you would like to export the data.
-



We recommend exporting the patient data using the "Single file (U12)" option.

4. Press the [...] button. (2).
5. In the dialog that appears, select the folder or the file to which the patient data should be exported.
6. Specify the name and destination of the file you are saving.
7. Make sure you have selected [Including Bitmaps].
8. Click [Export].
The patient and examination data have now been saved at the destination specified.

You can send data stored on the hard drive as an e-mail attachment.



Requirements for transferring data to another PC:

- The Pentacam® program must be installed on the other PC. If the program is updated on the Pentacam® PC (sender), the program on the other PC (recipient) must also be updated.
 - Make sure, that the PC is connected to a local network controlled by the Floating License Key or that a single license key is connected to the PC in order to interactively evaluate the exams.
-

7.7 Importing Patient Data

If you receive patient data, for example, on a USB stick, you can import these data.



Achtung

Risk of loss of data due to computer viruses

Computer viruses can cause loss of data.

→ Run a virus check before importing data from the USB flash drive.

1. Press the [Import] button. The following dialog appears:

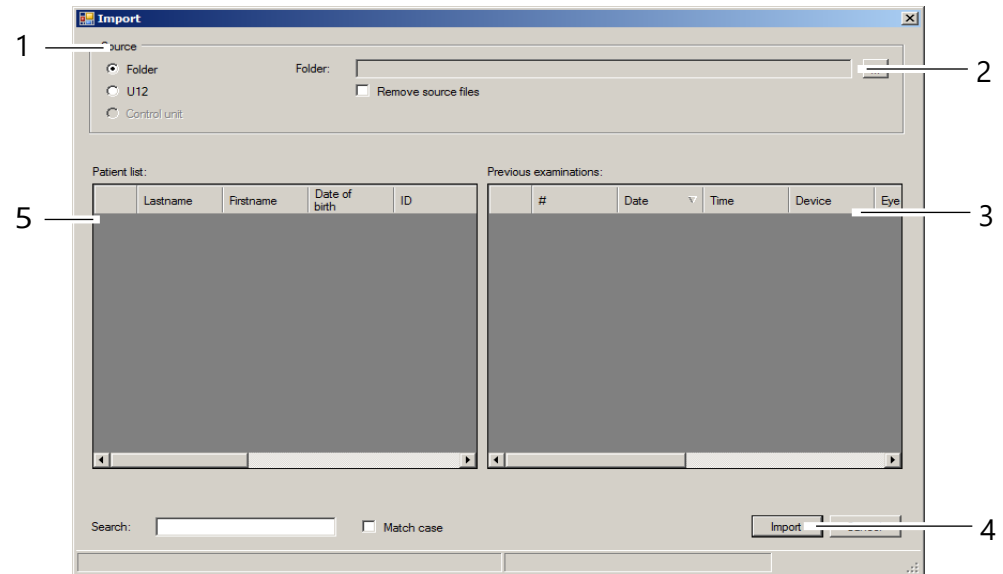

Fig. 7-6: "Import" dialog

No.	Beschreibung
1	Select data source
2	[...] button
3	Previous examinations
4	[Import] button
5	Patient list



The default options for import and export of data are configured in the "Settings" field, see also the [User Guide](#).

→ Depending on the settings, you may not have to perform all of the following steps (e.g. selection of the directory).

2. Select the option (1) where the source data are contained ("Folder" or "U12" (single file)).



Recommendation: Export the patient data using the "Single file (U12)" option.

3. Press the [...] button. (2).
4. In the dialog box, select the directory or the file where the patient data are located.
5. Confirm your selection with [OK] or [Open].

6. The patients and the associated examinations that are found are displayed in the lower part of the dialog.
7. To import the data, press the [Import] button (4).
The data will then be available in the Patient Data Management system.

7.8 Data Backup

You should make a backup copy of patient and examination data at regular intervals. In case of loss of data, you can reconstruct the data from a previously created backup with the help of this function. Since data backup takes several minutes, depending on the scope of the database and the data to be backed up, a backup should be carried out when the PC and the device will not be needed.



Note

Risk of loss of data due to computer viruses
Computer viruses can cause loss of data.

- ➔ Run a virus check before making a backup to an external a USB flash drive.



The general rules for security backups apply to the creation of backup copies created with the help of the Patient Data Management system. Storage of backup files should always be done on a separate system (for example an external hard drive or a USB flash drive with adequate capacity).

7.8.1 Backup Data

1. Press the [Backup] button at the top right of the Patient Data Management system. The following dialog is displayed:

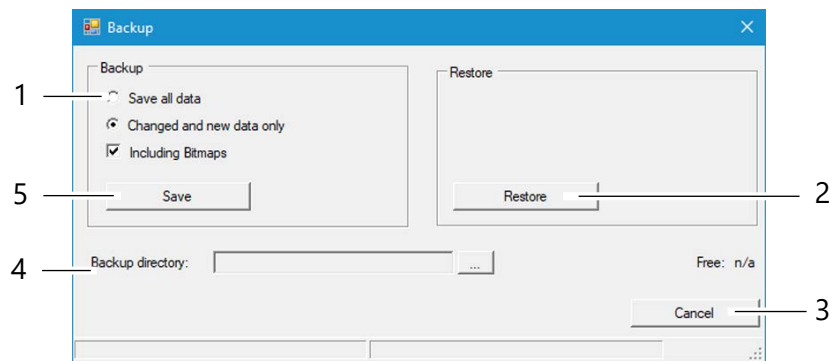

Fig. 7-7: "Backup" dialog

No.	Description
1	Backup data selection
2	[Restore] button
3	Display free storage space
4	Backup directory and button [...]
5	[Save] button

2. Select whether all of the data or only changed data should be backed up.



The Patient Data Management system internally tags all saved data records. If you select the option "Changed and new data only", only the data records that were not saved during a previous backup will be backed up.

3. Press the [...] button to the right of the "Backup directory" box (4).
4. In the dialog that appears, select the folder to which the data should be backed up.
5. Confirm your selection with [OK].
6. To back up the data, press the [Save] button (5). The previously selected data will then be backed up to the corresponding folder.

7.8.2 Reconstructing Data

If a loss of data occurs, the data from a previous backup can be re-imported into the Patient Data Management system.

1. Press the [...] button.
2. In the dialog that appears, select the folder which contains the backup data.
3. Confirm your selection with [OK].
4. To import the data, press the [Restore] button (2). All data in the appropriate directory are copied to the Patient Data Management system.

7.8.3 Automatic Backup

In addition to the manually performed backup, it is also possible to automatically run a backup when exiting the Patient Data Management system. The settings required for this can be made in the "Settings" area, see [User Guide](#).

In the patient data management you record and manage patient data.

8 Cleaning, Disinfection and Maintenance

Cleaning and disinfection of the Pentacam® / Pentacam® HR is described in this chapter.

Sterilization is not required.

- Heed the product descriptions and Instructions for Use of products and equipment you use to care for, clean, and disinfect the unit and/or its accessories.
- Do not clean the Pentacam® / Pentacam® HR with aggressive, chlorine containing, abrasive or sharp cleaning agents.

8.1 Intervals for Cleaning, Disinfection and Maintenance

Interval	Activity
before each use	Place fresh paper on the chin rest or disinfect the chin rest if it is used without paper
before each use	Disinfect forehead rest
monthly	Clean device (housing, illuminated slit)
monthly	Perform test measurement
every 2 years or after 25 000 measurements	Maintenance by OCULUS Service or an authorized dealer

8.2 Consumables

Chin rest paper	400 pcs., Order No. 65313
LidStick®	2 rolls with 100 pieces each, Order No. 77502
Desinfection wipes	mikrozyd® sensitive wipes premium Comp. Schülke & Mayr GmbH various pack sizes, e.g.: 2x 50 pcs. Softpack, Order No. 59882 SONO® Disinfecting wipes EPA Reg.No. 6836-340-89018 www.sonowipes.com PDI Sani-Cloth® AF3 Germicidal Disposable Wipe EPA Reg.No. 9480-9 www.pdihc.com

8.3 Cleaning



Attention

Risk of electric shock if the Pentacam® / Pentacam® HR is not completely disconnected from the mains for these jobs.

- Turn the Pentacam® / Pentacam® HR off, → [chap. 4.5 Switching Off, page 24.](#)

- Pull the power plug before cleaning. When disconnecting electrical connections, pull on the respective plug and not on the cable itself.

Required materials:

- Antistatic cleaning agent
- Cleaner for painted surfaces: Mixture of equal parts of alcohol and distilled water, possibly with a few drops of household detergent
- Soft, lint-free cloth
- Purified compressed air

8.3.1 Cleaning the Housing

- It is best to clean the housing surfaces with a soft cloth and an anti-static cleaning agent.
- Wipe off any residue from painted surfaces with the mixture for painted surfaces.

8.3.2 Clean chin rest and forehead rest

- Make sure that no liquid gets into any of the openings of the Pentacam® / Pentacam® HR.
Do not use liquid from aerosol cans.
- Clean the chin-forehead rest with a soap solution (or with alcohol, if very dirty).
- Use a lint-free, damp cloth.

8.3.3 Cleaning the illuminated slit

The optical components illuminating the slit, and the lens in front of the camera are precision parts and sensitive to pressure. The surfaces of these components are susceptible to scratching.



Attention

Damage to the optics due to improper cleaning

- When cleaning the illuminated slit, do not use a cloth or cleaning agents.

- Carefully clean the centre of the illuminated slit with purified compressed air.
- Clean the lens in front of the camera using a dry, lint-free cloth.

8.4 Disinfection

- Use disinfectant wipes that are suitable for medical devices. Recommendation refer → [chap. 8.2 Consumables, page 59](#).



Attention

Equipment damage caused by disinfectant solution

The disinfectant solution may damage the surface of the device if it is sprayed directly on it.

- Spray the disinfectant solution onto a cleaning cloth, do not spray it directly on the device.

- Disinfect the forehead rest after each examination.
- If you do not use paper for the chinrest, disinfect the chinrest after each examination.

8.5 Test measurements

The Pentacam® / Pentacam® HR is tested and calibrated in the Oculus factory. OCULUS Optikgeraete GmbH recommends to perform regular test measurements of the Pentacam® / Pentacam® HR.

A human eye should be measured initially. Minimum 5 consecutive measurements per eye should be done and the arithmetic mean has to be calculated and recorded.

Once in a month this measurement should be repeated using this eye as described above.

The arithmetic mean of the initial and the current measurement should be compared. The tolerance range of the original and the current results are described in the table chart below.

		Tolerance Range
Tomography	Basic	+/- 0.2 dpt
	HR	+/- 0.1 dpt
Pachymetry		+/- 10 µm

If the difference between the initial and the current measurement is outside the tolerance range, please inform us or contact your authorized Oculus distributor to get further support.

8.6 Maintenance

In order to retain the high measurement accuracy of the Pentacam® / Pentacam® HR OCULUS Optikgeräte GmbH recommends to perform a maintenance service every two years or after 25000 scans. A corresponding message appears.

- By daily pop up window
 - In the settings, see [User Guide](#) Date of next service and number of performed examinations
 - In the scan menu (→ chap. , page 29) as preliminary information (3 month before)
- bzw.
Information when service is due.
- During an examination (which is saved), an indicator appears next to the QA field.

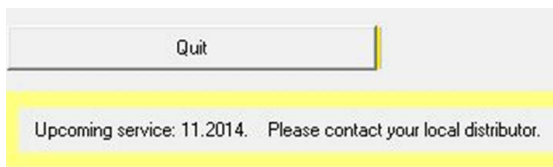
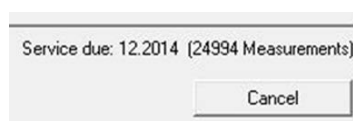
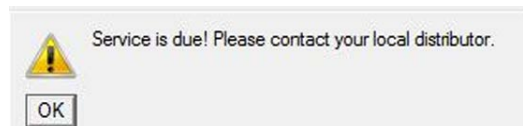

- Let the Pentacam® / Pentacam® HR checked by our service department or an authorized dealer.

8.7 Attaching Paper to the Chin Rest

If you want to attach new chin rest paper, follow these instructions:

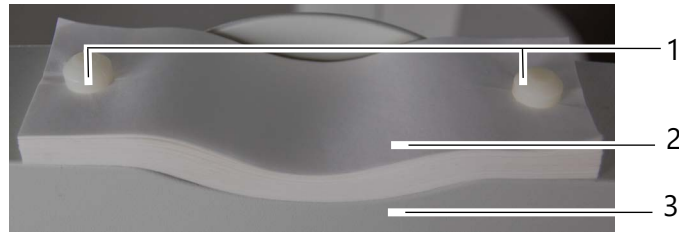

Fig. 8-1: Fasten chin rest paper

Nr.	Beschreibung
1	Pins
2	Paper for chin support
3	Chin rest

1. Pull the two pins out of the chin rest.
2. Place the chin rest paper in such a way that the holes of the paper and those in the chin rest are aligned.
3. Insert the two pins in the chin rest.

9 Troubleshooting



Caution

Personal injury or damage to equipment due to incorrect troubleshooting

- If an error occurs which you are unable to correct by following the instructions below, label the device as "out of order" and contact our service department or an authorised dealer.

Errors	Possible cause	Solution
After you have started the Pentacam® program, the following dialog box appears: "No communication with Pentacam!".	Power supply without voltage	<ul style="list-style-type: none"> Check whether the indicator light on the power supply is on. If not, connect the power supply to the mains.
	Power cord of the Pentacam® / Pentacam® HR not plugged in properly	Check whether <ul style="list-style-type: none"> the power supply cable is correctly attached to the Pentacam® / Pentacam® HR. the blue slit light is visible in the Scan menu (→ chap. , page 29). the USB connector is properly inserted.
	Software/hardware problems	<ul style="list-style-type: none"> Switch the Pentacam® off and restart the PC. Switch the Pentacam® on as soon as Patient Data Management becomes active. When you start the Pentacam® program, the message, "Load Bootloader" must appear. Contact the service department or your authorised dealer

10 Transport and Storage

The Pentacam® / Pentacam® HR, must be properly dismantled and packed before being transported or stored.



Caution

Risk of equipment damage due to incorrect shipment or from improper storage

- Avoid shocks, vibrations, and contamination.
- Avoid high temperatures and humidity.

- Transport the Pentacam® / Pentacam® HR carefully.
- Do not hold the device by the joystick to carry it.
- Store the Pentacam® / Pentacam® HR in compliance with the storage conditions.
- Avoid placing near heaters and moisture.

10.1 Storage conditions

Ambient temperature range	-10°C to +55°C
Relative humidity, including condensation	10% to 95%
Air pressure range	700 hPa to 1060 hPa

10.2 Transport conditions

Ambient temperature range	-40°C to +70°C
Relative humidity, including condensation	10% to 95%
Air pressure range	500 hPa to 1060 hPa

10.3 Disassembly

1. End the current session.
2. Switch off the device.
3. Disconnect the cable from the computer/laptop and the power adapter.



Fig. 10-1: Disassembly

4. Loosen the screw connection of the Y cable and pull it out.
When disconnecting electrical connections, pull on the respective plug and not on the cable itself.

11 Disposal



In accordance with Directive 2012/19/EC of the European Parliament and the Council and, in accordance with German law governing the marketing, return and environmentally compatible disposal of used electrical and electronic devices, such appliances must be recycled and may not be discarded as household waste.

- Dispose the Pentacam® / Pentacam® HR in a compliant manner.
Dispose of the device according to legal regulations.

12 Terms of Warranty and Servicing

Please note our General Terms and Conditions (GTC) on our website www.oculus.com.

13 Technical Data

Measuring equipment

	Pentacam®	Pentacam® HR
Camera	Digital CCD camera	Digital CMOS camera
Light source	Blue LED (475 nm, UV-free)	Blue LED (475 nm, UV-free)
Processor	DSP with 400 Mio. operationen/s	DSP with 400 Mio. operationen/s
Speed	50 images in 2 seconds ^a	100 images in 2 seconds ^b
Number of evaluated measuring points	max. 25.000	max. 138.000
Dimensions (W x D x H)	275 x 320 to 400 x 500 to 530 mm (10.8 x 12.6 to 15.7 x 19.7 to 20.9 in)	275 x 320 to 400 x 500 to 530 mm (10.8 x 12.6 to 15.7 x 19.7 to 20.9 in)
Weight	7,2kg ^c (15.9 lbs)	7,8 kg ^c (17.2 lbs)

a. Scheimpflug image of the entire anterior segment

b. Cornea fine scan

c. Weight without base

Measuring range

	Pentacam®	Pentacam® HR
Corneal topographer according ISO 19980	Type A	Type A
Curvature	3 – 38 mm 9 – 99 D	3 – 38 mm 9 – 99 D
Accuracy	± 0.2 D	± 0.1 D
Reproducibility	± 0.2 D	± 0.1 D
Working distance	80 mm (3.1 in)	80 mm (3.1 in)

Power adapter

Power adapter	HEMG49-S240210-7 (05150150)
Mains connection	100 – 240 V AC
Frequency	50/60 Hz
Power input, max.	85 VA
Output voltage	24 V DC
Fuses	Integrated overcurrent shut-off

Power supply

Output voltage	24 V DC
Electric consumption during operation with Pentacam [®]	35 W
Pentacam [®] HR	35 W

Life expectancy

Lifecycle expectancy	up to 10 years
----------------------	----------------

Classification according to IEC 60601 - 1

Type of protection against electrical shock	Protection class 2
Insulation of applied parts	Type B

Computer

The IT equipment (computer, monitor etc.) must comply with the requirements of IEC 62368-1.

Recommended computer specifications	Intel [®] Core™ i5, 500 GB SSD, 8 GB RAM, Windows [®] 11, Intel [®] HD Graphics
Recommended screen size	24"
Recommended screen resolution	1920 x 1080 Pixel (Full HD)

CE in accordance with Regulation (EU) 2017/745 on Medical Devices (MDR)

The unit is a class IIa product.



Conformity assessment procedure: (EU) 2017/745 MDR, Annex IX, chapter I and III.

14 Annex

14.1 Electromagnetic Compatibility

Medical electrical equipment is subject to special precautionary requirements with respect to EMC, and must be installed and operated according to the EMC-Instructions contained in the accompanying paperwork.

OCULUS devices and systems are suitable for use in professional healthcare establishments, e.g. doctor's practices or clinics; however, they may not be used in proximity to HF surgical units or inside of the HF shielded room of an ME system for magnetic resonance imaging. Portable and mobile HF communications appliances can affect medical, electric equipment.

No special measures need be observed in respect of OCULUS devices and systems.



Attention

Portable and mobile RF-communications devices can interfere with electrically operated medical devices and affect the performance of the device.

The device is intended for use in an electromagnetic environment in which the radiated RF interference is uncontrolled. The user can help prevent electromagnetic interference by maintaining the following minimum distance, based on the maximum output of the communication equipment, between portable and mobile RF communication devices (transmitters) and the device:

- Portable RF communication devices (including peripheral devices such as antenna cables and external antennas) should not be any closer than 30 cm (12 inches) to any part of the device.

Minimal performance quality and essential performance criteria

- A slightly disturbance of the analog camera of the Pentacam® / Pentacam® HR (slightly image noise on screen) during the examination is permissible because it will not affect the diagnosis, treatment and observation.
- A short flicker of the illumination of the Pentacam® / Pentacam® HR during the examination is permissible because it will not affect the diagnosis, treatment and observation.
- A short interruption of the USB connection during the examination is permissible because it will not affect the diagnosis, treatment and observation.



Caution

The use of accessories, transducers and cables specified by OCULUS with devices other than the Pentacam® / Pentacam® HR may result in increased emissions or decreased immunity of the other device.

- Do not use the accessories, transducers and cables specified by OCULUS with devices other than the Pentacam® / Pentacam® HR.
- Use only the original accessories, transducers and cables specified by OCULUS.

To be in compliance with the requirements of the IEC 60601-1-2 the following types of equipment, accessories, power adapters and cables must be used.

Order number	Description	
70700	Pentacam®	
10010403	Pentacam® HR	
05200320	Cable with connector plug, EU standard	2.5 m (98.4 in)
05200210 (110 Volt)	Cable with connector plug, US standard	2.5 m (98.4 in)
05150150	Power adapter HEMG49-S240210-7	24 V, 2,1A
017090000052	Y cable with galvanic isolation	2 m

14.2 Guidance and Manufacturer's Declaration - Electromagnetic Emissions and Immunity

Guidance and manufacturer's declaration electromagnetic emissions IEC 60601-1-2

The OCULUS Pentacam® / Pentacam® HR is intended for operation in the electromagnetic environment specified below. The user of the Pentacam® / Pentacam® HR should ensure that it is being used in such an environment.

Emissions test	Compliance	Electromagnetic environment - guidance
RF emissions CISPR 11	Group 1	The Pentacam® / Pentacam® HR uses RF energy only for its internal function. Therefore, its RF emissions are very low and are not likely to cause any interference in nearby electronic equipment.
HF-emissions CISPR 11	Class B	
Harmonics emissions IEC 61000-3-2	Class A	
Voltage fluctuations / flicker emissions IEC 61000-3-3	complies	

Electromagnetic immunity, IEC 60601-1-2			
Immunity test	IEC 60601 test level	Compliance level	Electromagnetic environment - guidance
Electrostatic discharge (ESD) IEC 61000-4-2	± 8 kV contact ± 15 kV air	± 8 kV ± 15 kV	Floors should be made of wood or concrete or covered with ceramic tiles. If the floor is covered with synthetic material, the relative humidity must be at least 30%.
Power frequency (50/60Hz) magnetic field IEC 61000-4-8	30 A/m 50 Hz or 60 Hz	30 A/m 50 Hz or 60 Hz	Power frequency magnetic fields should be at levels characteristic of a typical location in a typical commercial or hospital environment.
Electrical Fast transient/bursts IEC 61000-4-4	± 2 kV for power supply lines 100 kHz repetition frequency ± 1 kV for input/output lines	± 2 kV ----- ± 1 kV	Mains power quality should be that of a typical commercial or hospital environment.
Surge IEC 61000-4-5	± 1 kV line(s) to line(s) ± 2 kV line(s) to earth	± 1 kV differential mode ± 2 kV line(s) to earth	Mains power quality should be that of a typical commercial or hospital environment.
Voltage dips, short interruptions, and voltage variations on power supply input lines IEC 61000-4-11	0% U_T ; 1/2 period at 0, 45, 90, 135, 180, 225, 270 and 315 degree 0% U_T ; 1 period and 70% U_T ; 25/30 periods Single-phase: at 0 degree 0% U_T ; 250/300 periods	0% U_T ; 1/2 period at 0, 45, 90, 135, 180, 225, 270 and 315 degree 0% U_T ; 1 period and 70% U_T ; 25/30 periods Single-phase: at 0 degree 0% U_T ; 250/300 periods	Mains power quality should be that of a typical commercial or hospital environment. If the user of the Pentacam® / Pentacam® HR requires continued operation during power mains interruptions, it is recommended that the Pentacam® / Pentacam® HR be powered from an uninterruptible power supply or battery.
Note: U_T is the a.c. mains voltage prior to application of the test level.			

Electromagnetic immunity, IEC 60601-1-2

Immunity test	IEC 60601 test level	Compliance level	Electromagnetic environment - Guidelines
<p>Conducted RF IEC 61000-4-6</p> <p>Radiated RF IEC 61000-4-3</p>	<p>3 V_{eff} 150 KHz to 80 Mhz 6 V in ISM- and amateur radio frequency bands between 150 kHz and 80 MHz 80% AM to 1 kHz</p> <p>3 V/m 80 MHz to 2,7 GHz 80% AM at 1 kHz</p>	<p>V_{eff} = 3 V</p>	<p>Portable and mobile RF communications equipment should be used no closer to any part of Pentacam® / Pentacam® HR, including cables, than the recommended separation distance calculated from the equation applicable to the frequency of the transmitter. Recommended separation distance</p> $d = \left[\frac{3,5}{(V_1)} \right] \sqrt{P}$ $d = \left[\frac{3,5}{(E_1)} \right] \sqrt{P} \quad 80\text{MHz to } 800 \text{ MHz}$ $d = \left[\frac{7}{(E_1)} \right] \sqrt{P} \quad 800 \text{ MHz to } 2.5 \text{ GHz}$ <p>where P is the maximum output power rating of the transmitter in watts (W) according to the transmitter manufacturer and d is the recommended separation distance in metres (m). Field strength from fixed RF transmitters, as determined by an electromagnetic site survey (a), should be less than the compliance level in each frequency range (b). Interferences may occur in the vicinity of equipment marked with the following symbol:</p> 

Note 1: At 80 Hz and 800 MHz, the higher frequency range applies.
 Note 2: These guidelines may not apply in all situations. Electromagnetic propagation is affected by absorption and reflection from structures, objects and people.

- a. Field strengths from fixed transmitters, such as base stations for radio (cellular/cordless) telephones and land mobile radios, amateur radios, AM and FM radio broadcast, and TV broadcast cannot be predicted theoretically with accuracy. To assess the electromagnetic environment due to fixed RF transmitters, an electromagnetic site survey should be considered. If the measured field strength in the location in which the Pentacam® / Pentacam® HR is used exceeds the applicable RF compliance level above, the Pentacam® / Pentacam® HR should be observed to verify normal operation. If abnormal performance is observed, additional measures may be necessary, such as re-orienting or relocating the Pentacam® / Pentacam® HR.
- b. Over the frequency range 150 KHz to 80 MHz, field strengths should be less than 3 V/m.

Recommended separation distances between portable and mobile RF communications equipment and the Pentacam® / Pentacam® HR, IEC 60601-1-2

The Pentacam® / Pentacam® HR is intended for use in an electromagnetic environment in which radiated RF disturbances are controlled. The customer or the user of the Pentacam® / Pentacam® HR can help prevent electromagnetic interference by maintaining a minimum distance between portable and mobile RF communications equipment (transmitters) and the Pentacam® / Pentacam® HR as recommended below, according to the maximum output power of the communications equipment.

Rated maximum output power of transmitter W	Separation distance according to frequency of transmitter m		
	150 KHz to 80 Mhz $d = 1.2 \sqrt{P}$	80 MHz to 800 MHz $d = 1.2 \sqrt{P}$	800 MHz to 2.5 GHz $d = 2.3 \sqrt{P}$
0.01	0.12	0.12	0.23
0.1	0.38	0.38	0.73
1	1.2	1.2	2.3
10	3.80	3.80	7.3
100	12	12	23

For transmitters rated at a maximum output power not listed above, the recommended separation distance d in metres (m) can be estimated using the equation applicable to the frequency of the transmitter, where P is the maximum output power rating of the transmitter in watts (W) according to the transmitter manufacturer.

NOTE 1: At 80 MHz and 800 MHz, the separation distance for the higher frequency range applies.

NOTE 2: These guidelines may not apply in all situations. Electromagnetic propagation is affected by absorption and reflection from structures, objects and people.

14.3 Description of the Connection

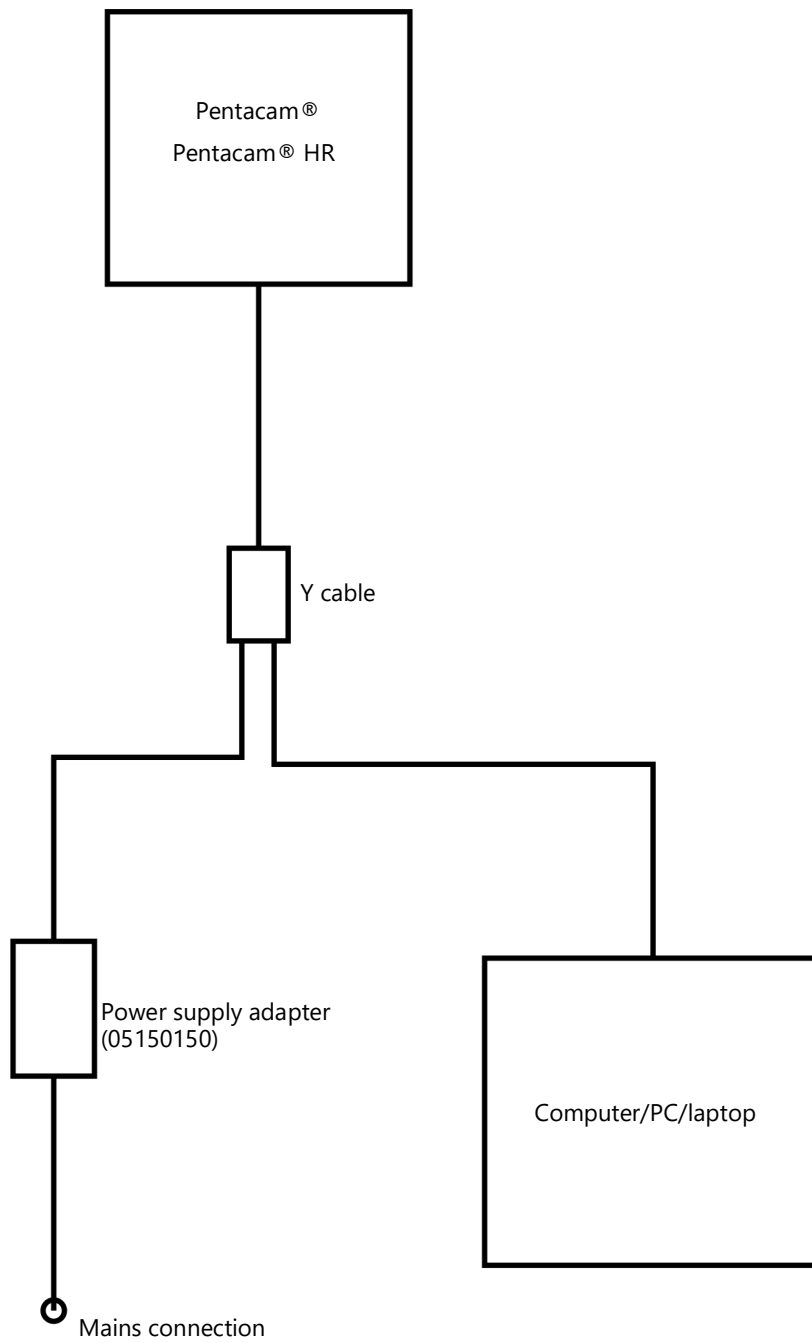

14.4 Data sheet HEMG 49-S240210-7 (05150150)

HiTRON

**UNIVERSAL INPUT AC-DC MEDICAL & ITE APPLICATION
EXTERNAL DESKTOP SWITCHING ADAPTER 48-50 WATTS
GREEN POWER SINGLE OUTPUT HEMG49 SERIES**



FEATURES:

- ACCOMMODATE UNIVERSAL AC INPUT
- MEET MEDICAL STANDARDS IEC60601-1 & ITE STANDARDS IEC60950-1
- EMI MEET EN 55011 & EN55022 / FCC CLASS B
- MEET ENERGY STAR LEVEL V & CEC LEVEL IV
- CE MARKING COMPLIANCE

SPECIFICATION

INPUT SPECIFICATION

Input Voltage: Typical 90-264Vac.
Input Connector: 3 pole AC inlet IEC320-C14(DT7) / 2 pole AC inlet IEC320-C8(DT8).
Input Frequency: 47-63Hz.
Inrush Current: 12Arms (52Apk) at 230Vac.
Input Current: Typical 0.91A at 115Vac/ 0.57A at 230Vac.
Dielectric Withstand: Meet IEC60601-1 & IEC60950-1.
EMI: Meet EN55011 & EN55022 / FCC Class B.
Hold-up Time: Typical 12mS at 115Vac. Typical 70mS at 230Vac.
Over Temp. Protection: Optional (NTC circuit).
Earth Leakage Current (Class I) : Less than 0.3 mA.
Touch Leakage Current (Class I & II) : Less than 0.1mA.
No Load Power: Less than 0.3W at 230Vac

OUTPUT SPECIFICATION

Output Voltage: See Ratings Chart.
Output Current: See Ratings Chart.
Output Wattage: Typical 48-50Watts.
Output Connector & Cord: Optional.
Line Regulation: Typical 0.1%.
Load Regulation: Typical ±1.5-3.0%.
Noise & Ripple: 1.0% peak to peak.
OVP: Built-in by latch circuit.
Adjustability: Factory set.
Over Current Protection (OCP):
 Fully protected against output overload and short circuit.
 The PSU will shut down after OCP is activated.
 Consult the factory for OCP setting.

GENERAL SPECIFICATION

Efficiency: Typical 87%-88% (various with the output voltage)
Switching Frequency: Typical 65KHz.
Circuit Topology: Fixed Frequency Flyback circuit.
Transient Response: Output voltage returns in less than 5.5mS following a 50% load change.
Safety Standard: Meet Medical IEC60601-1 & ITE IEC60950-1, Class I for DT7(C14) or Class II for DT8(C8)
Operating Temperature: 0°C to +40°C.
Storage Temperature: -20 to +85°C.
Cooling: Free air convection.
Construction: Impact resistant thermo-plastic enclosure case.
Power Density: 3.14-3.27Watts. / Cubic inch.
Desktop Format.

NOTE: (1) All measurements are at nominal input, full load, and +25°C unless otherwise specified.
 (2) Load regulation is measured at 115Vac or 230Vac in percentage to indicate the change in output voltage as the load varied from half load to full load (±%).
 (3) The exact obtainable load regulation depends upon the output cord selected and load current.
 (4) Due to requests in market and advances in technology, specifications subject to change without notice.



For the details of safety approval, please consult the factory.

OUTPUT VOLTAGE / CURRENT RATINGS CHART

SINGLE OUTPUT

MODEL NO.	AC INLET	O/P VOLTAGE	O/P CURRENT
HEMG49-S120400-7	IEC320-C14(DT7)	12.0Vdc	4.0A
HEMG49-S120400-8	IEC320-C8(DT8)	12.0Vdc	4.0A
HEMG49-S150330-7	IEC320-C14(DT7)	15.0Vdc	3.3A
HEMG49-S150330-8	IEC320-C8(DT8)	15.0Vdc	3.3A
HEMG49-S240210-7	IEC320-C14(DT7)	24.0Vdc	2.1A
HEMG49-S240210-8	IEC320-C8(DT8)	24.0Vdc	2.1A

MECHANICAL DIMENSIONS: MM [INCHES]

WEIGHT: 373.0g (13.2 Oz.)

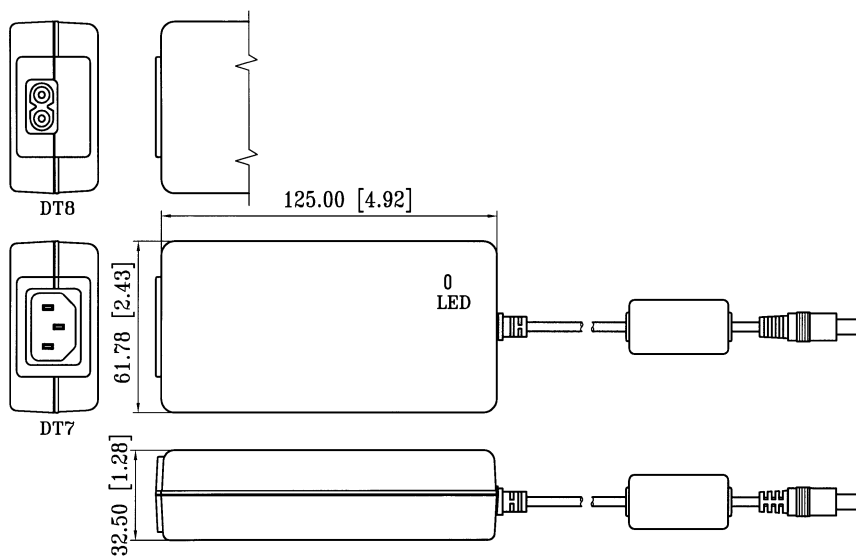

14.5 Instructions for integration into an IT-Network

The device, in conjunction with the connected computer and the device software running on it, forms a programmable electrical medical system (PEMS) according to IEC 60601-1.

It is essential that you follow the chap. "2.3 Instructions on Cyber Security" on page 16 of "Safety Instructions for Use" (page 13) in the device Instructions for Use.

Please note the following information for implementing an integration of the PEMS into an IT-Network:

The purpose of integrating the PEMS into an IT-Network can be:

- Licensing by local license server
- Storage and retrieval of the examination data on a local network drive
- Printing
- Data export
- DICOM workflow

Required characteristics of the IT-Network into which the PEMS is to be integrated:

- Prefer wired LAN connection
- IPv4 network
- Fast-Ethernet (100 Mbit/s minimum)

Required configuration of the IT-Network into which the PEMS is to be integrated:

- Licensing: required opened ports: 3968 TCP; 51371 - 51372 UDP
- Storage, printing, data export: File and Printer Sharing for Microsoft Networks (SMB 3.0 or higher - required opened port: 445]
- DICOM Storage Service Class = PACS
- DICOM Worklist Management Service Class (Modality Worklist Server)

Technical specifications of the network connection with the PEMS, including the specifications of data security:

- Refer to the „Instructions on Cyber Security" section (chap. "2.3 Instructions on Cyber Security" on page 16).
- Refer to the "Floating License Key - License management for software options" Instructions for Use (if applicable)
- Refer to device specific DICOM interface description (if applicable)

The intended flow of information between PEMS, the IT-Network and other devices in the IT-Network and the intended routing through the IT-Network

- License handling from local license server to PEMS and vice versa
- Storage and data export to local network storage and loading from local network storage
- Printout to local printer

List of hazard situations that result from the IT-Network being unable to provide the features that are required to fulfill the purpose of integrating the PEMS into to meet the IT-Network:

- Loss of data
- unsuitable data exchange
- Data corruption
- unsuitable temporal data allocation
- unexpected data reception
- unauthorized access to data



Connection of the PEMS to an IT-Network that includes other equipment could result in previously unidentified risks to patients, operators or third parties. The responsible organization should identify, analyze, evaluate and control these risks.

Subsequent changes to the IT-Network could introduce new risks and require additional analysis.

Changes to the IT-Network include:

- changes in IT-Network configuration
- connection of additional items to the IT-Network
- disconnecting items from the IT-Network
- update of equipment connected to the IT-Network

WWW.OCULUS.DE

OCULUS Optikgeräte GmbH

Münchholzhäuser Str. 29 • 35582 Wetzlar • GERMANY

Phone +49 641 2005-0 • Fax +49 641 2005-255

E-mail: sales@oculus.de • www.oculus.de

OCULUS Inc.

17721 59th Avenue NE • Arlington • WA 98223

Phone +1 425 670 9977 • Fax +1 425 670 0742

E-mail: sales@oculususa.com • www.oculususa.com

10039981 / US / Rev04
Lot:

