

OCULUS Keratograph 5M



INSTRUCTION MANUAL

Measurement and Evaluation System for Corneal Topography

Notes on this Instruction Manual

The Keratograph 5M was manufactured and tested under strict quality criteria. To ensure safe operation, it is essential that you use the device correctly. For this reason, you should thoroughly familiarize yourself with the contents of this instruction manual before operating the device. Pay attention to the safety instructions!

This instruction manual describes how to manage the patient data and the procedures for conducting measuring operations with the Keratograph 5M.

Additional information that goes beyond the scope of this manual can be found in the Keratograph 5M user manual.

Due to ongoing development, the diagrams shown here may vary slightly from the actual software delivered.

If you have any questions or would like additional information about your device, please do not hesitate to contact us by mail or fax. Our team will be happy to assist you.

Item Number: G/77000/XXXX/EN

Release: 13.07.2022

Revision: 03

Table of Contents

1	Delivery and Deliverables	1
1.1	Software Version	2
2	Symbols	3
3	Structure of the Documentation.....	4
4	Safety Instructions.....	5
4.1	About this Manual	5
4.1.1	Pictograms Used in this Manual.....	5
4.2	Safety Instructions for Use	6
4.3	Cybersecurity Instructions	10
5	Intended Use.....	13
6	Device Description.....	14
6.1	Keratograph 5M Functionality.....	15
7	Set up and Connection	17
7.1	Connect the Foot Switch.....	17
7.2	Electrical Connection	18
8	Initial Operation.....	19
8.1	Switching On	19
8.2	Switching Off.....	19
8.3	Using the wireless joystick.....	20
9	Preparing for Measurements.....	21
9.1	Starting Patient Data Management.....	21
9.1.1	Entering a New Patient	22
9.1.2	Selecting an Existing Patient.....	22
10	Keratograph Software	24
10.1	Starting the Keratograph 5M Software	24
10.1.1	Performing a Reference Measurement	25
10.2	Loading an Existing Examination.....	26
10.2.1	Print Screen	26
10.3	Preparing the Examination	27
10.3.1	Checking the Examination Conditions.....	27
10.3.2	Preliminary Adjustment.....	27
10.4	Starting the Examination	30
10.5	Camera Alignment	31
10.6	Image Capture with the Foot Switch.....	32
10.7	Completing a Measurement.....	32
10.8	Performing a "Topography" Examination	33
10.8.1	New Measurement	34
10.8.2	Measuring the Back Surface of a Contact Lens.....	36
10.9	Performing a "TF-Scan" Examination	39
10.9.1	Examination of the Lipid Layer	40
10.9.2	TF-Dynamic Examination.....	41
10.9.3	Measuring the Tear Meniscus Height	42
10.9.4	Measuring NIKBUT.....	43

10.10	Performing an "R-Scan" Examination	44
10.11	Performing a "Meibo-Scan" Examination	45
10.12	Performing a "Pupillometry" Examination	47
10.12.1	Adjustment.....	48
10.12.2	Diagram	48
10.12.3	Pupillogram.....	49
10.12.4	Asymmetric Test	49
10.12.5	Manual	49
10.13	Imaging.....	50
10.13.1	Recording a Fluo Image.....	51
10.13.2	Near Portion Height Measurement.....	52
10.13.3	Eyelid Angle Measurement.....	53
10.13.4	New Recording.....	54
10.13.5	Adjusting Illumination, Magnification Changer and Camera	55
10.14	Performing Dry Eye Examinations JENVIS Dry Eye Report	58
10.14.1	Selecting the Exam Type	59
10.14.2	Performing the selected examination.....	60
10.14.3	Filling in the „Recommendation" field.....	61
10.14.4	Printing the JENVIS Dry Eye Report.....	61
10.14.5	DEQ OSDI.....	62
10.14.6	LIPCOF	63
10.15	Performing a JENVIS Pro Dry Eye Report.....	64
10.15.1	Perform the capture plan based on the worklist	65
10.15.2	Additional supporting information	66
10.15.3	Adjusting Illumination, Magnification Changer and Camera (7).....	67
10.15.4	Printing a JENVIS Pro Dry Eye Report	72
11	Managing Patient Data	73
11.1	Rename Patient Data	73
11.2	Exporting Patient Data	73
11.3	Importing Patient Data.....	74
11.4	Data Backup.....	76
11.4.1	Backup Data	76
11.4.2	Reconstructing Data	77
11.4.3	Automatic Backup	77
12	Reference Measurement	78
13	Maintenance, Cleaning and Repair.....	80
13.1	Cleaning.....	81
13.2	Disinfection.....	82
13.3	Maintenance.....	82
13.4	Attaching Paper to the Chin Rest.....	83
14	Troubleshooting.....	84
15	Transport and Storage.....	85
15.1	Transport and Storage Information.....	85
15.2	Disassembly.....	86

15.3	Transport and Storage.....	86
16	Disposal	87
17	Terms of Warranty and Servicing	87
17.1	Terms of Warranty.....	87
17.2	Assumption of Liability for Functions and Damage	88
17.3	Manufacturer and Service Address	88
18	Technical Data.....	89
19	Annex	92
19.1	Electromagnetic Compatibility.....	92
19.2	Guidance and Manufacturer's Declaration - Electromagnetic Emmissions and Immunity for the Keratograph 5M	93
19.3	Description of the Connection.....	97
19.4	Data Sheet HEMG 49-S240210-7 (05150150)	98
19.5	Instructions for integration into an IT-Network	100

1 Delivery and Deliverables

Products and accessories	Order number
Keratograph 5M (measuring device) multiple versions	77000
Imaging Software	77130
OCULUS wireless joystick	18200
Keratograph 5M accessories	77001
■ Power adapter 24 V	05150150
■ Dust cover	02 60100 05 001
■ Reference sphere	77007
■ Contact lens holder	70512
Keratograph 5M user package	77002
■ Instruction Manual	G/77000/XXXX/EN
■ User Guide	UG/77000/XXXX/EN
■ Software installation	SI/50000/XXXX/EN
■ Power cord	
USA	05200210
England	05200211
Australia	05200212
EU	05200320
Switzerland	05200322
Argentina	05200323
■ Connection cable	
Med. secure Isolator + USB Connection acc.	70002
Extension cable for Med. secure Isolator length 4 m	10002173
■ Floating License Key with OcuLicenseServer-Software and manual	77900
	SI/77900/XXXX/EN
Optional:	
■ JENVIS Pro Dry Eye Report	77250
- R-Scan	77110
- TF-Scan	77120
- Meibo Scan	77140
■ Pupillography	70542
■ DICOM/PACS Interface	70681
■ OxiMap®	70679
■ Hard drive, package	70005
■ USB Foot switch	77006

Products and accessories	Order number
■ Support plate (size 360 mm)	78060
■ Long support plate (size 490 mm)	78030
■ Long support plate adjustable for OCVLUS rack wheels (size 360 – 460 mm) without chin rest	78070
■ Long support plate adjustable for OCVLUS rack wheels (size 360 – 460 mm) with chin rest	78080

We reserve the right to change the scope of delivery in line with ongoing technical development.

- ➔ If you find transport damage upon delivery, immediately file a claim with the transport company.
- ➔ Have the damages noted on the bill of lading, so that your claim for damages can be handled properly.

For more information regarding shipping and handling, see [sec. 15, page 85](#).

1.1 Software Version

- Patient data management: from version 6.09
- Keratograph software: from version V2.14r7



- The software version of the patient data management appears on the "Settings - Main" screen page (patient data management).
 - The software version of the Keratograph 5M program appears in the Help menu.
-

2 Symbols

Symbols on the device		Symbols, packaging			
	Manufacturer		Protection class		Keep dry
	Date of manufacture	IP XX	Type of protection		This way up
	Conformité européenne		Article number		Fragile
	Follow instruction for use		Serial number		Transport Limit of temperature for transport
	Disposal in household trash is prohibited		Medical device		Storage Limit of temperature for storage
	Applied part Type B		Caution		Limit of humidity
(21) ABCDEFG123456789 (01) 04049584000040	Example: UDI number, consisting UDI-DI (Device-Identification) UDI-PI (Product Identifier) machine-readable matrix code				Limit of air pressure

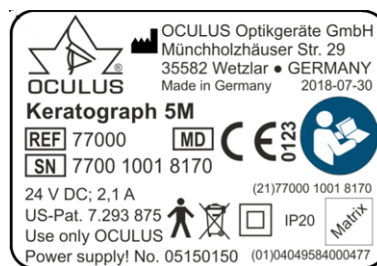

Fig. 2-1: Name plate (example)

3 Structure of the Documentation

A folder containing documentation is supplied with your Keratograph 5M:

- **Instruction Manual:** The design of the unit is described in detail in this document. The instruction manual also gives you general information about working with the Patient Data Management system and all safety-related instructions for use of the Keratograph 5M.



Attention

All safety-related instructions for use of the Keratograph 5M are given in the Instruction Manual for the unit. It is imperative that you read and understand the whole Instruction Manual before you use the Keratograph 5M.

- **User Guide:** All features of the examination and analysis software are described in the User Guide, along with detailed information about the Patient Data Management system.
- **Software Installation:** The introduction to the Software Installation describes how to install the Keratograph 5M software and the associated drivers.

Manual Floating License Key: information on the use of the Keratograph 5M within networks.

External software: „Description of external Software data interface“ describes settings and data formats.

4 Safety Instructions

4.1 About this Manual

- ➔ Carefully read through the Instruction Manual.
- ➔ Keep the Instruction Manual in good condition near the device.
- ➔ Observe the legal regulations with regard to accident prevention.

If standards are named without an issue date, the current version always applies.

4.1.1 Pictograms Used in this Manual



Attention

Identifies a potentially dangerous situation which may cause minor injury or damage to property.



Note

Denotes situations which could result in incorrect findings, denotes user instructions and useful or other important information.



Identifies important information about the product and its use which require special attention.

- > This symbol denotes menu paths and screenshots. Example for starting a new examination:
Keratograph 5M > Examination > New
which means:
 - ➔ Select the "Examination" menu from the menu bar.
 - ➔ Select the menu item "New".

4.2 Safety Instructions for Use



Attention

Personal injury or property damage due to improper operation

→ Observe the following safety instructions.

Personal injury or property damage due to equipment modifications that could jeopardize safety

- No modifications may be made to this device without the permission of the manufacturer. Only the OCULUS service are allowed
- to modify the device or the associated lifting table
 - to install software and software updates.
-

Any serious-incident that has occurred in relation to the device should be reported to the manufacturer (vigilance@oculus.de) and the competent authority of the region in which the user and/or patient is established.

Instructions for Operating Personnel

- Make certain that the Keratograph 5M is used exclusively in clinics and by eye specialists and opticians (trained staff etc.).
For this reason the device may only be operated by personnel instructed to do so, who, with appropriate training, knowledge and practical experience, are able to ensure proper handling of the device.

Transport and Storage Instructions

Refer to the notes in *sec. 15, page 85*.

Instructions for Setup and Connection

- Only OCULUS or an authorized dealer is allowed to set up and to connect the Keratograph 5M.
- Do not use or store the Keratograph 5M in rooms that are humid, see *sec. 15, page 85*.
- Keep the Keratograph 5M away from water that may drip, splash or spray on it, and make sure that no liquids can get into the Keratograph 5M. Do not place any containers holding liquids in the vicinity of the Keratograph 5M.
- Germany: Only operate the Keratograph 5M in rooms used for medical purposes after they have been set up according to the VDE Regulation 0100-710.
- Do not operate the devices included in the delivery in areas where explosions may occur, or in proximity to flammable anesthetics or volatile substances such as alcohol, benzine or similar products.

- ➔ Set up the Keratograph 5M so that the power plug is easy to access. That way, you can easily disconnect it from the power supply for any repairs or maintenance work.
- ➔ Do not force any plug connections.
If you are unable to make a plug connection, check whether the plug fits the socket.
If you detect damage to the connection, you should let authorized dealer repair the damage.
- ➔ Only use a device which is mounted at the lifting table properly.

Patient environment information

Patient environment is the area where patients can come into contact with any part of a medical electrical equipment (ME equipment) or with another person being in contact with the ME equipment.



Attention

In the patient environment, use devices that conform to IEC 60601-1. If a multiple power socket is to be used, or if a device is to be used that does not meet the IEC 60601-1 standard, use an isolating transformer.

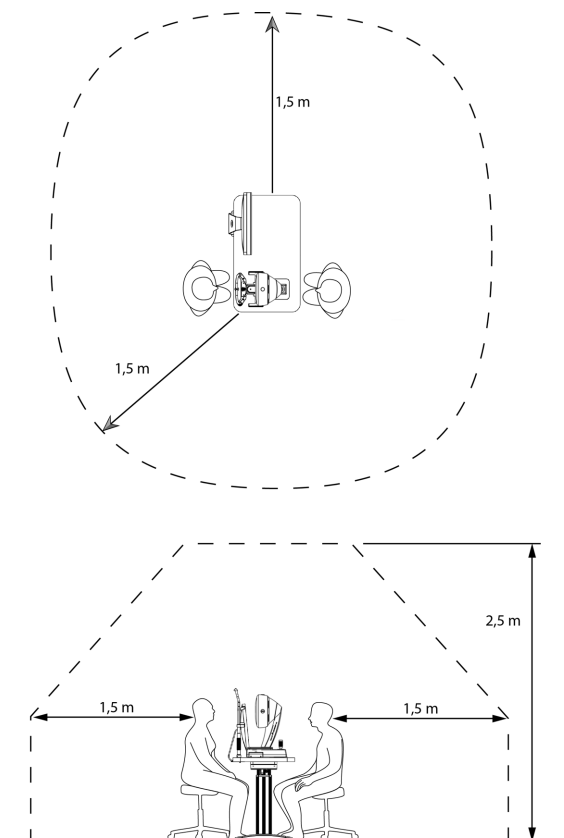

Fig. 4-1: Patient environment

Information about the operation of an ME system

The Keratograph 5M and a connected computer form a medical electrical system (ME system) according to IEC 60601-1. If you connect additional devices, such as, for example a printer, those devices become part of the ME system.

- Make sure that all devices of the ME system meet the requirements of IEC 60601-1 or IEC 60950-1/IEC 62368-1.

Instructions for Operation

- Before first use: Let OCVLUS or an authorized dealer train you in the operation of the Keratograph 5M.
- Never operate a damaged Keratograph 5M.
- Only operate the Keratograph 5M with the original accessories supplied by us and only when the unit is in technically perfect condition. Use only the power supply unit specified in the scope of delivery.
- Do not cover the ventilation openings.
- Do not touch the patient and the device at the same time.
- Make sure that the device cannot tip over by leaning against it or sitting on it.
- Do not put the Keratograph 5M including rechargeable battery or cable, down onto devices that produce heat, heaters (for example radiators), microwaves or similar.
- Only operate the device if you have understood the operating instructions.

Instructions for Maintenance

To ensure satisfactory and reliable operation, we recommend that you have the Keratograph 5M checked every two years by our service department or an authorized dealer. If an error occurs which you cannot correct, label the Keratograph 5M as being "out-of-order" and contact our service department see [fig. 17.3, page 88](#).

Instructions for Disassembly and Disposal

- When disconnecting electrical connections, pull on the respective plug and not on the cable itself.
- Dispose of the device according to legal regulations.

Instructions on Electrical Safety



Attention

Risk of personal injury or damage to property due to an incorrect level of safety

Connecting the Keratograph 5M with its non-medical electrical equipment (e.g. data processing equipment) to a medical electrical system must not result in a patient safety level below that prescribed by IEC 60601-1. If making this connection leads to the leakage current threshold being exceeded, protective measures including a circuit breaker must be in place.

- Ensure that connections with non-medical devices are made correctly.
- Only use the power adapter listed in the packing list.
- Use only a computer that meets the specifications given in this instruction manual, [sec. 18, page 89](#).

Use of a multiple socket extension cord

Risk of personal injury or material damage caused by unsafe multiple socket extension cord

If you use a multiple socket extension cord to connect the Keratograph 5M to the power supply, you must heed the following information:

- Use an extension cord that complies with the requirements of IEC 60601-1, section 16.
- Do not place the multiple socket extension cord on the floor.
- Do not use more than one multiple socket extension cord.
- Plug only the Keratograph 5M and the computer that is being used with the unit (if applicable) into the multiple socket extension cord.

If you are using a multiple socket extension chord it has to be supplied with a isolation transformer.

If you are using a new computer for the Keratograph 5M, you must have the electrical safety checked. Call OCULUS Service for this purpose.



Attention

Electromagnetic Compatibility (EMC) / Cables

Risk of personal injury or damage to property due to electromagnetic interference

Portable and mobile RF communications equipment can affect medical electrical equipment [sec. 19.1, page 92](#).

- ➔ Make sure that portable and mobile RF communications equipment do not cause interference.
- ➔ Recommendation: Maintain a minimum distance of 4 m. If the distance is shorter, you must ensure that the Keratograph 5M functions correctly.

4.3 Cybersecurity Instructions



The device itself was not designed to connect via a coupled computer to the internet or other network, or to portable media, as the device does not require a network or internet connection to function.

User who elect to connect the device coupled computer to the internet or other network for other purposes are responsible for ensuring that it is done so in a controlled manner.

Data responsibility:

The device itself is not designed to connect with the internet, but only with a computer. It does not require Internet access for regular use.

Do not connect with the internet while using the device. It is considered misuse.

If you elect to connect the computer to the internet for other purposes you are responsible for ensuring data security.

Device Security

It is the responsibility of the authorized user to ensure that the Keratograph 5M device is not left unlocked, or otherwise unsecured when not in use, to ensure that non-authorized medical, professional, or otherwise unapproved personnel are not exposed to, or gain access to, ePHI.

User Responsibility

User names or passwords must not be shared with colleagues or others, even if they are permitted by law and provider policy to view the same type of information (e.g. two operators reviewing the same patient samples).

Operators have access to patients' ePHI and must not take snap-shots, screenshots or pictures (e.g. using another device) of any information viewed through the device.

Operators should not enter identifying data into the device. All the data on the device should be de-identified and relate to the sample id and not to the patient.

Reporting Device Security or Privacy Breaches

Operators must contact their local IT department and disclose any suspected or confirmed compromised user accounts, and any other privacy or security breaches.

Recovering from Compromised Accounts or Devices

When accounts are considered compromised, devices are lost, or unauthorized access is discovered or suspected, the Healthcare Organization's IT network administrators suspend and modify the user login criteria and issue new login credentials for the user to access their account securely.

Unavailable Service

Users should report unavailable service or prohibited access to information to their local Healthcare Organization's IT department.

Precautions

→ To ensure cyber security in order to the usage of the device, the following security measures should be considered. Contact your computer administrator:

Precautions for access control of the computer

- Secure the computer with a password (for example at Windows start up).
- Choose a complex password: A good password should be at least eight characters long and are not in the dictionary. In addition to letters, it should also include numbers and special characters.
- Do not choose a name or device name for a password (for example "Keratograph").
- Change the password regularly.
- Do not note the password in an accessible location.
- Use different passwords for different users.
- Enable the screen saver and use the option for the necessity of reentering the password when exit the screen saver.
- Choose an adequate time setting for starting the screen saver if software session is inactive (e.g. 10 minutes). Adequate time setting should consider duration of examination, number of patients, time between examinations, use of other devices in the examination room, several user, etc.
- Lock the computer if you are leaving the workstation (shortcut: 'windows logo key' + 'L').

Precautions if the computer is connected to a LAN or internet network

- If you elect to connect the computer to the LAN or internet, you are responsible for ensuring data security.
- Prefer wired connections of the computer to the network.
- If you are using Wi-Fi connections nevertheless, please ensure the usage of adequate security methods (for example WPA2/AES – Wi-Fi Protected Access / Advanced Encryption Standard – with a strong network key).
- The usage of a firewall (software or hardware) is recommended.

Heed the instructions for integration into an IT-Network [sec. 19.5, page 100](#)



Do not use the Keratograph 5M with wireless technology, for example with wireless USB (connection between device and computer)

5 Intended Use

The OCULUS Keratograph 5M is a measuring instrument for examination of the eyes and must only be used for the purpose specified in this instruction manual.

The instrument is used to measure corneal topography and is designed for

the purpose of fitting contact lenses.

You can use this device for screening for dry eye.

The OCULUS Keratograph 5M is intended for use in optometrist practices,

in clinics and by opticians. It must be used with the examination station intended for that purpose or with an examination unit.

Intended medical indication

The Keratograph 5M can be used by clinicians and optometrists to examine the following points:

- corneal topography
- contact lens fitting
- dry eye screening

Intended medical indication

The Keratograph 5M may only be used for the purpose described in this instruction manual.

➔ Heed the safety instructions listed above.

Contraindication

none known

Possible side effects

none known

Intended users

Make certain that the Keratograph 5M is used exclusively in clinics and by clinical persons or eye specialists (trained staff etc.)

- who can guarantee proper handling due to their knowledge, training and practical experience.
- who have been instructed by OCULUS staff or an authorized dealer before the initial operation.

Patient group

Children from 3 years up to geriatric patients. No restrictions on weight, health and condition. Patient is awake and able to understand and to look on a fixation target.

6 Device Description



Fig. 6-1: Equipment overview of the Keratograph 5M

6.1 Keratograph 5M Functionality

The OCULUS Keratograph 5M combines the keratometric measuring process with topographic mapping.

Measurement of the corneal surface is done by means of a Placido ring system that is reflected off the cornea. These data are analyzed by the computer.



Note

Data misuse

OCULUS Optikgeräte GmbH shall not be liable in any form for further use of the data recorded with the Keratograph 5M or for any calculations based thereon.

Technical Principle

An illumination system with a special reflector illuminates a transparent Placido bowl from the rear which contains a series of concentric rings .

The image of this Placido bowl is reflected off the patient's eye.

This virtual image is captured by a precision objective and a connected high-resolution color camera.

All distortions due to the different radii of curvature of the patient's eye that become visible are available for the measuring process.

The analog image is first prepared for analysis in the measuring unit, i. e. it is digitized and compressed for processing in the computer.

When the computer has received the respective dataset for the measurement image, it develops a topographic map of the cornea based on that data.

It displays the measurement results on the monitor as a color map, a graph and as a spatial image.

Applied parts



1 Forehead rest

2 Chin rest

Abb. 6-2: Applied parts

7 Set up and Connection



Attention

Risk of incorrect measurements/equipment damage due to improper set-up

Before first use

- Make sure the installation and connection of the "Keratograph 5M" examination station are completed by our service or by a professional authorized by OCULUS.
 - Let OCULUS or an authorized dealer train you in the operation of the Keratograph 5M.
-



Note

- Do not expose the Keratograph 5M to any vibrations, shocks, contaminants, moisture, or high temperatures.
 - Handle the optical device with care.
-

You will find the operating conditions in [sec. 18, page 89](#).

- Set up the Keratograph 5M so that the power plug is easy to access. That way, you can easily disconnect it from the power supply for any repairs or maintenance work.
- Place the device so that direct light cannot affect the measurement.
- Make sure the examination is free from reflections. To achieve this, darken the examination room.

7.1 Connect the Foot Switch

You can connect a foot switch, if needed. With this, you can trigger the image capture. For a video, you can start and stop the recording by pressing this foot switch, [sec. 10.7, page 32](#).

Requirement: USB connection

- Plug the USB connector of the foot switch into a USB port at your computer.

The foot switch is active.

7.2 Electrical Connection



Attention

Electrical safety hazard

- ➔ Do not use the Keratograph 5M adjacent to or stacked with other equipment.
- ➔ If you have to use the Keratograph 5M adjacent to or stacked with other equipment, verify the correct operation of the Keratograph 5M.
- ➔ Only use the power adapter listed in the list, [sec. 19.1, page 92](#).
- ➔ Only use a power cord which meets the requirements of the standards IEC 60227-1, Type H03VH2-F, min. 0.75 m² and IEC 60320-1, Type C7.
- ➔ If you use a power strip to connect the Keratograph 5M: Use a power strip that complies with the requirements of DIN EN 60601-1.
- ➔ Do not place the multiple socket extension cord on the floor.
- ➔ Do not use more than one multiple socket extension cord.
- ➔ Plug only the Keratograph 5M and the computer that is being used with the unit (if applicable) into the multiple socket extension cord.
- ➔ Use a socket with a protective earth connection which is fully operating.



Fig. 7-1: Connecting

- ➔ Plug the connector of the Y cable into the jack and tighten the connection. Make sure that the plug is inserted in the correct position.



Note

Risk of equipment damage due to incorrect connection

If you do not connect the Keratograph 5M properly, and the connection is live, the unit can be damaged within a short period of time.

- Do not use excessive force when connecting the electrical plug.
- Pay attention to the specifications on the nameplate.

If the electrical plug is damaged, contact our service department or an authorized dealer to repair the damage.

- Firmly tighten the connection.
- Connect the Y-cable to the computer/laptop and the power adapter.

8 Initial Operation

- Wait approx. 3-4 hours after transport before operating the Keratograph 5M for the first time. Extreme temperature changes from cold areas to warm rooms can cause condensation on the optical components.

8.1 Switching On

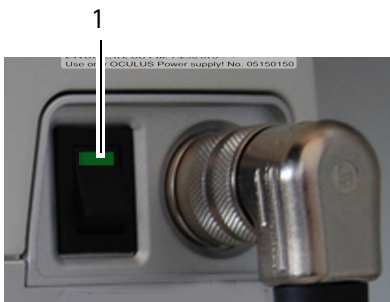

- The first step is to switch on the computer or laptop.
- Then turn on the Keratograph 5M with the on/off switch (position ON). The LED (1) on the switch lights up green.

8.2 Switching Off

- Close the Keratograph 5M program and close the Patient Data Management.
- Shut down the Windows operating system.
- Turn the Keratograph 5M off with the on/off switch (OFF position).



Attention

Risk of electric shock if the Keratograph 5M is not completely disconnected from the mains for transport, cleaning, maintenance, disinfection and repair.

- Turn the Keratograph 5M off.
- Pull the power plug before cleaning. When disconnecting electrical connections, pull on the respective plug and not on the cable itself.

8.3 Using the wireless joystick

If your device is equipped with a wireless joystick, you can use it to capture various images.



This is the joystick icon that appears on the screen.

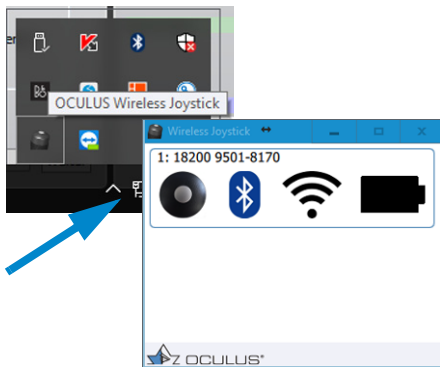

- ➔ Make sure that the wireless joystick has been selected. To do so, open the hidden icons in the task bar. In the system tray, you should see the icon for the OCULUS wireless joystick. Click it to see the joystick status, e.g. battery charge level.
- ➔ Touch the joystick to activate it. Within 2 seconds, it will establish communication with the computer and the examination software. The LED on the Bluetooth USB adapter will be red.



Fig. 8-1: Joystick with trigger button (arrow)

- ➔ To take a measurement: press the joystick button.
- ➔ To record video: press and hold the joystick button.

As long as the joystick button is held down, the LED on the Bluetooth USB adapter flashes red.

If the joystick is left idle for 90 seconds, the connection to the Bluetooth USB adapter will be dropped in order to conserve battery power. The red LED on the Bluetooth USB adapter will then turn off.



The battery lasts approx. one year on average. Once the battery has been used up, a battery change notification is displayed in the examination software.

9 Preparing for Measurements

9.1 Starting Patient Data Management

You can enter patient data in the Patient Data Management and then use it. After you have switched on the computer, it loads the operating system.

➔ If necessary, click on the Keratograph 5M icon:

The user interface for the Patient Data Management appears.

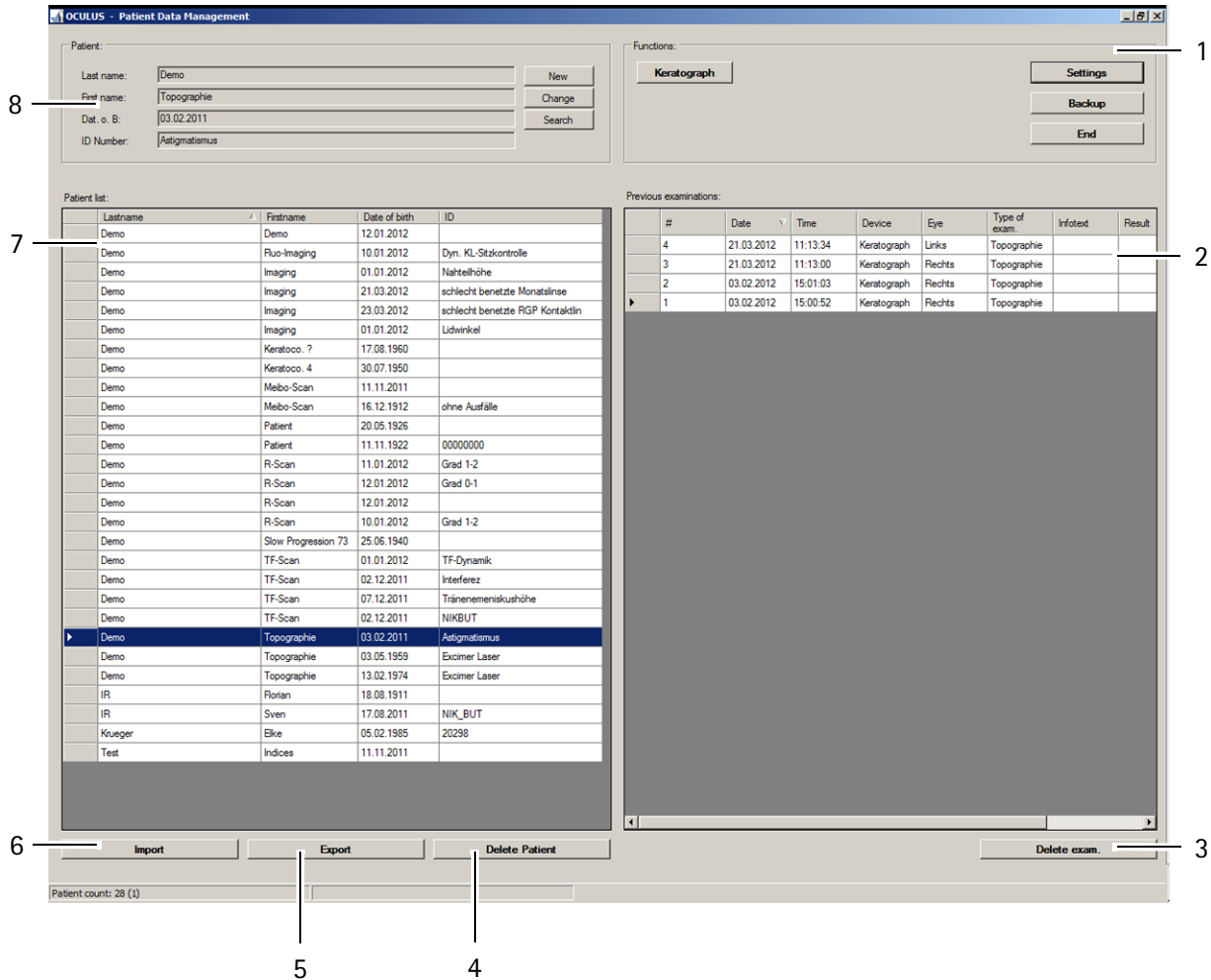

- 1 "Functions" group box
- 2 Previous examinations
- 3 [Delete exam.] button
- 4 [Delete Patient] button
- 5 [Export] button
- 6 [Import] button
- 7 Patient list
- 8 "Patient" group box

Fig. 9-1: Patient Data Management user interface

If the Windows desktop appears, you have to start the Patient Data Management program from there.



To get to the Keratograph 5M program, you must first enter a new patient (8) or select an existing patient from the examination list (2).

For more information on Patient Data Management, refer to the [sec. 11, page 73](#).

9.1.1 Entering a New Patient

- ➔ Press the [New] button to enter a new patient in the Patient Data Management system.
- ➔ Enter the patient's last name, first name and date of birth in the patient window.

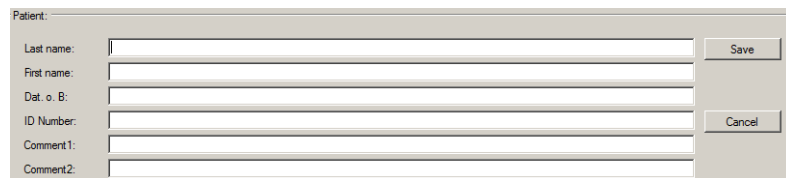

Fig. 9-2: Entering patients

Optionally you can enter an ID number for the patient.

- ➔ To save the data you entered, click [Save].
- The patient you have just entered now appears in the patient list.

9.1.2 Selecting an Existing Patient

The patient data list on the left-hand side of the screen displays all previously examined patients in alphabetical order.

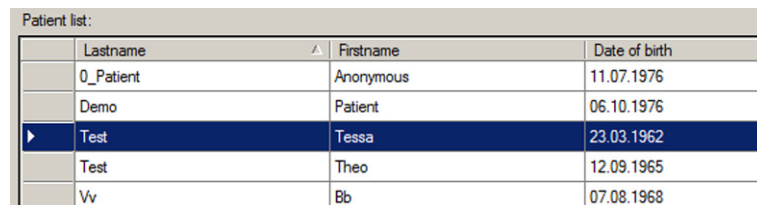

Patient list:		
Lastname	Firstname	Date of birth
0_Patient	Anonymous	11.07.1976
Demo	Patient	06.10.1976
Test	Tessa	23.03.1962
Test	Theo	12.09.1965
Vv	Bb	07.08.1968

Fig. 9-3: Patient list

- ➔ Choose [Search] to quickly find the patient you are looking for in the list.
- ➔ Enter the patient's name or the first letter of the name in the "Last name" field.
Alternatively, you can search for the patient using an ID number, first name or date of birth, assuming that one was assigned when the patient was first recorded.
- ➔ In the list that appears, click the entry you were searching for to transfer the patient's name to the patient window. This also brings up a list of any previous examinations for that patient in the examination window (bottom right side).

Extended Patient Search: [Extended] Checkbox

➔ Click on the [Extended] checkbox.

The screen displays additional search parameters which reference previous examinations. Proceed as for the input of a patient name.

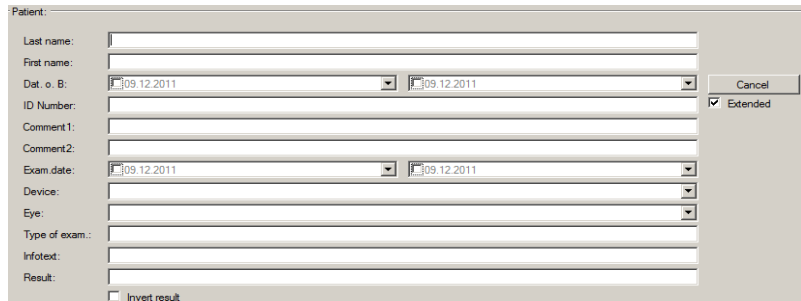

The screenshot shows a 'Patient:' dialog box with the following fields and controls:

- Last name:
- First name:
- Det. o. B.:
- ID Number:
- Comment 1:
- Comment 2:
- Exam date:
- Device:
- Eye:
- Type of exam.:
- Infotext:
- Result:
- Invert result
- Buttons: Cancel, Extended

Fig. 9-4: Advanced search

10 Keratograph Software



The Instruction Manual concentrates on how to operate the Keratograph 5M. The functional description of the Keratograph software is therefore limited to the respective measuring procedure and to loading existing examinations.

For detailed information about measurement evaluations, refer to the User Guide.

10.1 Starting the Keratograph 5M Software

Transition Patient Data Management > Keratograph 5M Program

- ➔ After selecting a patient: Double click on an examination from the examination list to start the Keratograph 5M program.

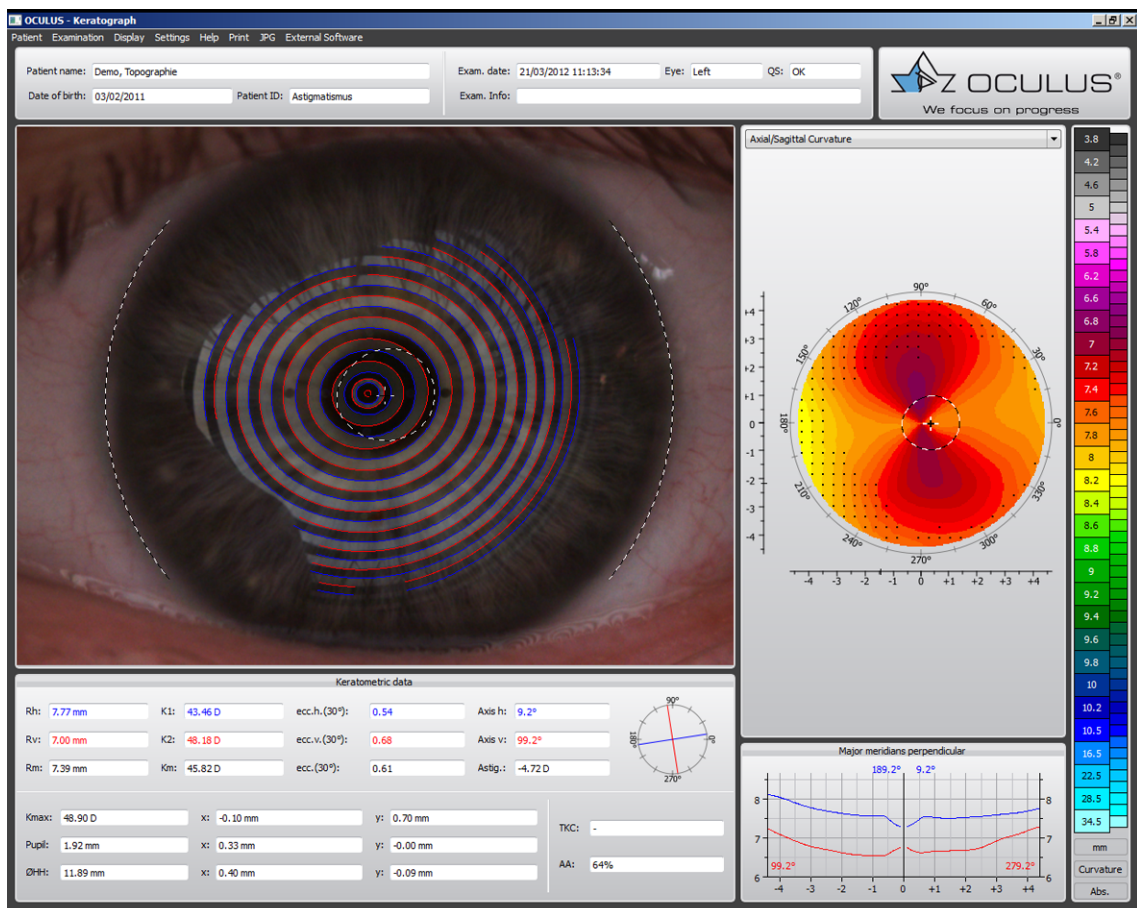

Fig. 10-1: Overview example with a topographic examination

or

- ➔ After selecting a patient: Press the [Keratograph] button to start the Keratograph 5M program.

or

- ➔ Double-click the selected patient name to start the Keratograph 5M program.

The following items appear on every screen.

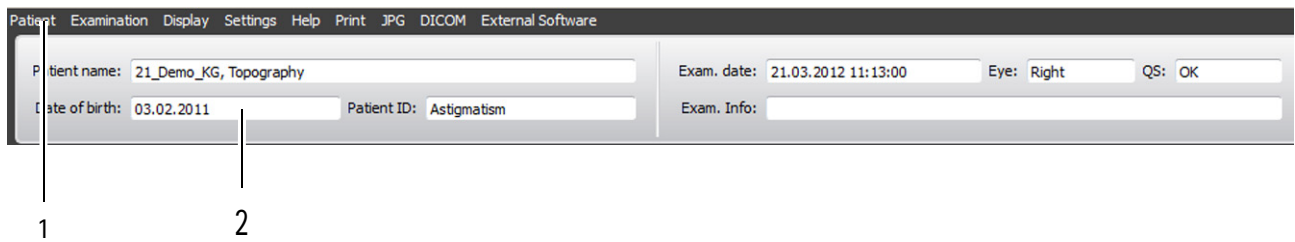

1 Menu bar

2 Examination and patient data

Fig. 10-2: Keratograph 5M program menu bar

10.1.1 Performing a Reference Measurement



Before the first measurement you need to perform a reference measurement.

- ➔ Select the menu item [Settings].
- ➔ Choose [Reference Measure].

For how to perform a reference measurement see [sec. 12, page 78](#).

10.2 Loading an Existing Examination

- ➔ Select the [Examination] menu item and click on [Load]
The "Examination Explorer" screen opens.

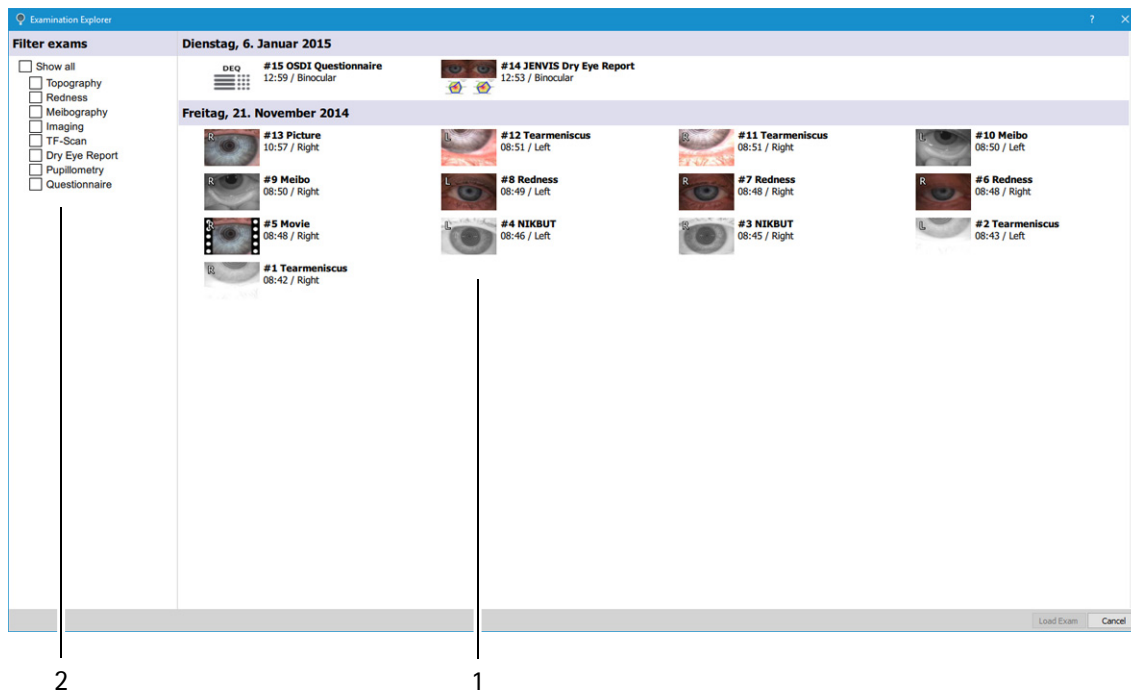

- 1 Filter exams
- 2 Preview of examinations

Fig. 10-3: Selecting and loading examination

- ➔ If necessary, select an examination filter, for example "Topography". Only the topography examinations will appear in the preview.
- ➔ Select the desired examination by clicking on it.
- ➔ Confirm with [Load Exam] or double click.
The desired examination is loaded in the Keratograph 5M program.



When performing certain measurements e.g. tear meniscus height measurement, you are led directly to the evaluation menu by pressing the [Image] button.

10.2.1 Print Screen

- ➔ Select the menu item [Print].
The Print menu appears.
- ➔ Select the desired printer and enter the settings.
- ➔ Press the [Print] button.
The currently displayed screen is printed.

10.3 Preparing the Examination



Attention

Risk of incorrect measurement due to incorrect use

Before first use

- Make sure the installation and connection of the "Keratograph 5M" examination station are completed by our service or by a professional authorized by OCULUS.
 - Let OCULUS or an authorized dealer train you in the operation of the Keratograph 5M.
-



Recommended for beginners: Practice the entire measurement process a few times using the supplied reference sphere ([sec. 12, page 78](#)).

10.3.1 Checking the Examination Conditions

- Make sure that no interfering light gets into the viewer of the Keratograph 5M.
If necessary, darken the room.

10.3.2 Preliminary Adjustment

- Check that fresh paper has been put onto the chin rest, [sec. 13.1, page 81](#). If you do not use chin rest paper: Disinfect the chin rest after each examination.
- Check that the forehead rest has been cleaned and disinfected after each examination, [sec. 13.2, page 82](#).
- Ask the patient to put his chin on the chin rest.
- Do not touch the patient and the Keratograph 5M simultaneously.
- Adjust the height of the table so that the patient's head rests comfortably on the chin-forehead rests.

- ➔ Adjust the chin rest so that the patient's eyes are approximately at the level of the black ring on the chin-forehead rest (1).

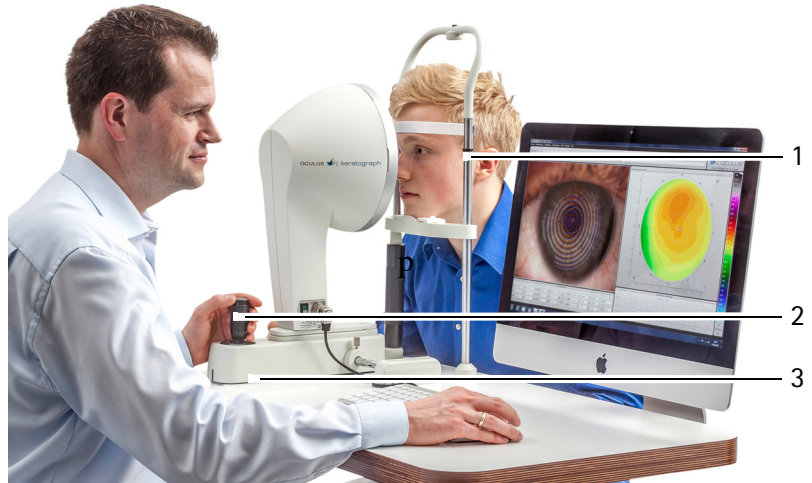

1 Chin-forehead rest with marking 3 Adjusting base
 2 Joystick with twist handle
 Fig. 10-4: Patient positioning

- ➔ Example of preliminary adjustment for the right eye: To do this, move the adjusting base (1). The marking on the back of the adjusting base (3) must roughly coincide with the circle R (5).

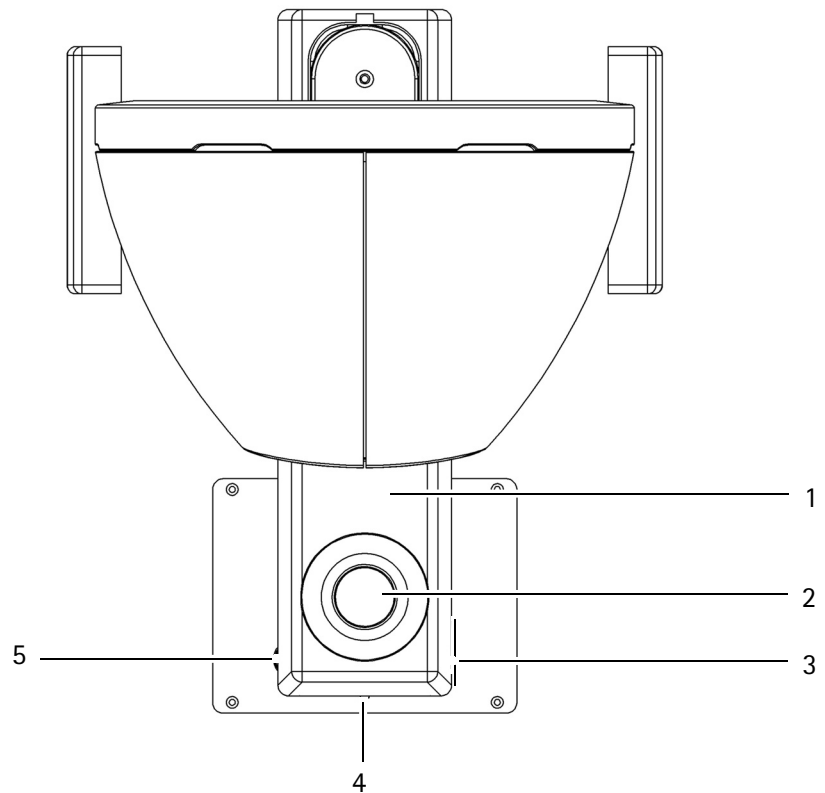

- | | |
|-------------------------------|---------------------------------|
| 1 Adjusting base | 4 Marking on the adjusting base |
| 2 Joystick | 5 Circular mark right (hidden) |
| 3 Circular mark left (hidden) | |

Fig. 10-5: Preliminary adjustment

- ➔ If necessary, correct the position of the adjusting base.
- ➔ Instruct the patient to focus on the red light in the center of the rings during the entire measurement.

10.4 Starting the Examination

- ➔ In the "Examination" menu, select [New].
The following screen will appear:

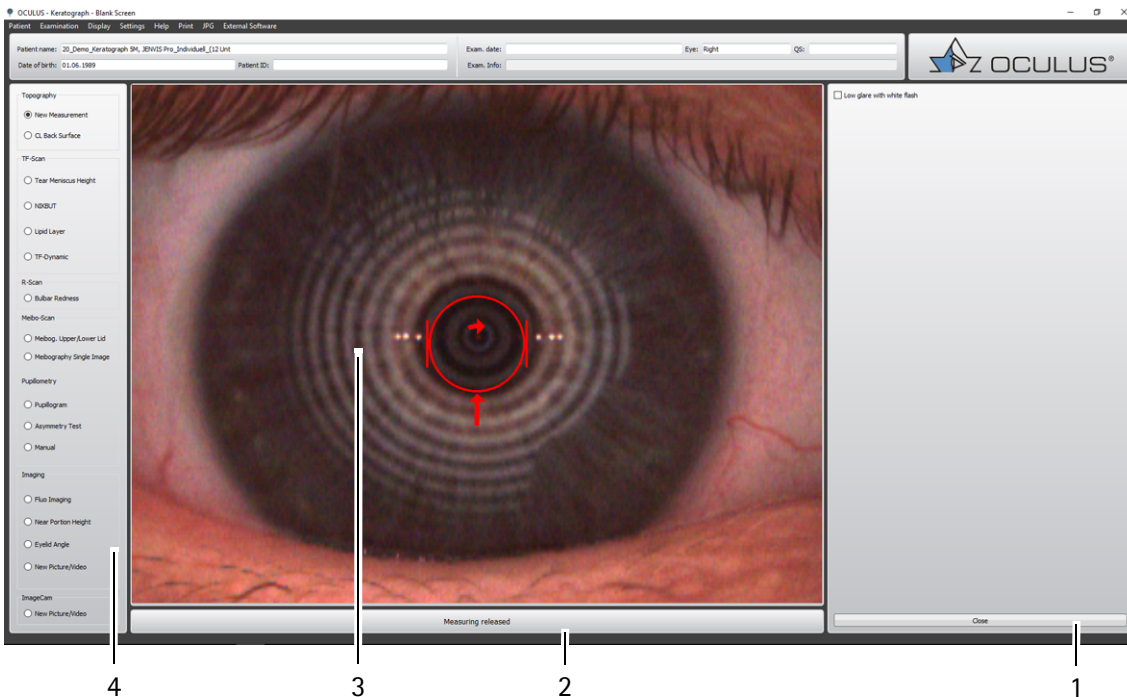

- | | |
|---|---|
| 1 [Close] button
2 [Measuring released] button | 3 Current camera image with cross hair
4 Examination bar |
|---|---|

Fig. 10-6: Overview of the exams, topography example

The examinations are listed in the examination bar (4). Examinations that are not enabled are grayed out.



See the User Guide for information about the evaluation of the examinations.

- ➔ Enable the radio button for the desired examination.

10.5 Camera Alignment

In the measuring functions „Topography“ and „NIK BUT“, the measurements are triggered automatically. The camera must be accurately aligned for this purpose.

- ➔ Position the measuring head in front of the eye so that the keratometry marks are in focus (see figure).
- ➔ Precisely align the camera. To do so, move or turn the joystick in the specified directions:



Example:

- ➔ Move the joystick to the right.
- ➔ Rotate the joystick clockwise.

Arrow	Camera movement	Joystick movement
➔	right	Move the joystick to the right
➜	left	Move the joystick to the left
➕	forward	Move the joystick toward the patient
➖	back	Move the joystick away from the patient
➡	up	Rotate the joystick clockwise
➠	down	Rotate the joystick counter-clockwise



When the position has been approximately reached, a cross appears in the center of the ring that is bordered by four bars.

The Keratograph 5M will automatically begin measuring.



Note

For some measurements, the „Illumination“, „Magnification Changer“ and „Camera“ groupboxes appear. You can set values for illumination, magnification changer and camera. You can save the settings as a program.

- ➔ Proceed according to [sec. 10.13.5, page 55](#)

Manual Measurement

In rare cases, for example when highly irregular corneas are present, the measurement cannot be triggered automatically.

- ➔ Press the spacer bar to disable the automatic triggered measurement.
- ➔ Press the Enter key to trigger the measurement manually.

Or

- ➔ Press the spacer bar and then the foot switch.

The measurement is triggered manually.

A manually triggered measurement may not be reproducible.

10.6 Image Capture with the Foot Switch

For measuring functions in which a single image is to be captured (snap shot), or a video is to be recorded (e.g. measurement of the tear meniscus height, R-Scan, Meibo-Scan, etc.) for the purpose of documenting the findings, you can simplify the process by using the foot switch.

- ➔ Capture image: Press the foot switch briefly.
- ➔ Record video: Press the foot switch and hold it down for the duration you want to record the video.

To end the video recording, take your foot off the foot switch.

10.7 Completing a Measurement

- ➔ Ask the patient to remove his head from the chin-forehead rest.
- ➔ If necessary, make preparations to examine another patient.
- ➔ Disinfect the forehead rest after each patient, [sec. 13.2, page 82](#).
- ➔ In the menu bar select the "Patient" menu and click on [New Patient/End].

10.8 Performing a "Topography" Examination

- ➔ Start the Keratograph 5M software, [sec. 10.1, page 24](#).
- ➔ Select "Examination" from the menu bar and click on the [New] item. The following screen page appears:

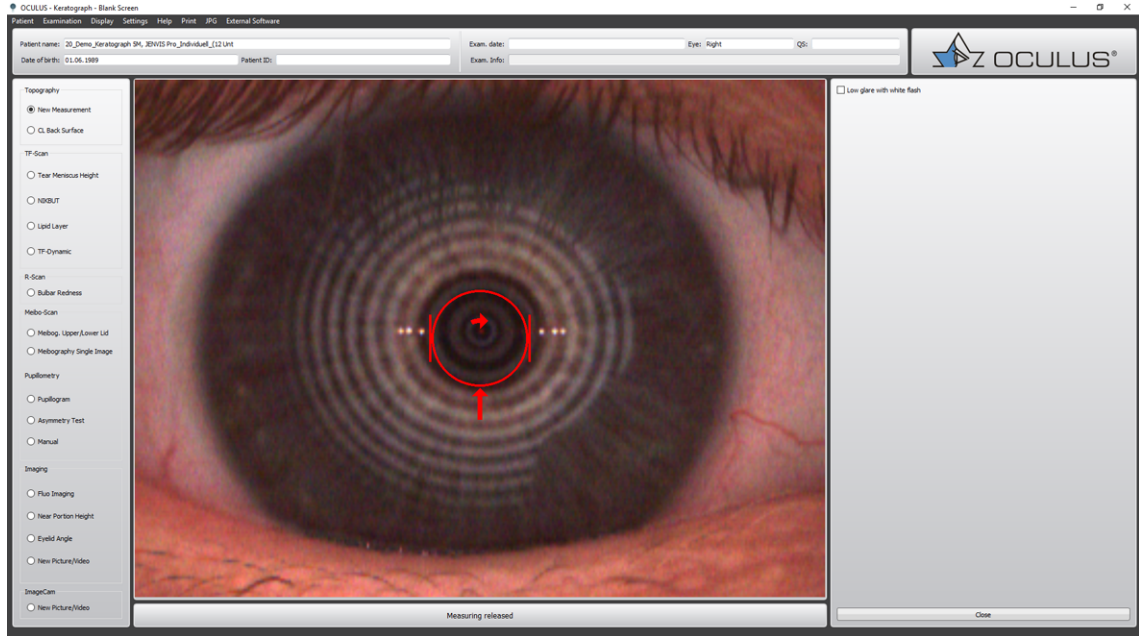
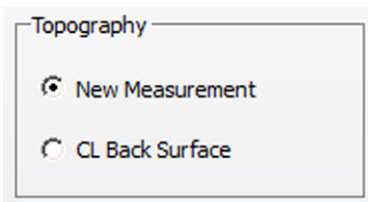

Fig. 10-7: Topography examination



10.8.1 New Measurement

- ➔ Enable the radio button [New Measurement].
- ➔ Align the camera, [sec. 10.5, page 31](#).



If your patients are sensitive to glare activate the function: Low glare with white flash.

The complete aligning process between Keratograph and the patient's eye is performed under infrared light. Just the capturing process itself is conducted with white light. So the patient is able to open his/her eyes wider than under white light conditions which leads to a bigger corneal coverage.

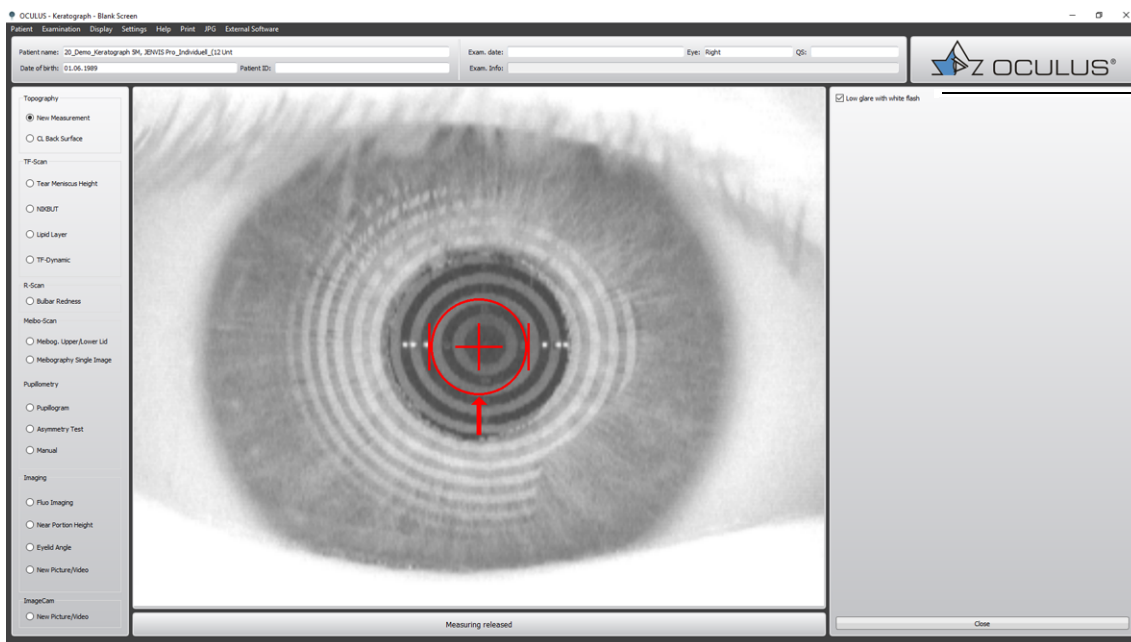

1 Function „Low glare with white flash“
 Abb. 10-8: Topography examination with white flash

Marking the Placido Rings Manually

If considerable corneal irregularities are present, the keratometry marks may not be on a plane with the center point of the Placido rings. Automatic analysis of the topography data is then not possible. In that case, you will be prompted to manually mark the center of the Placido rings (*"Manual Measurement" page 32*).

- Click with the left mouse button on the center point of the rings projected on the cornea.

The topography of the cornea is then calculated.

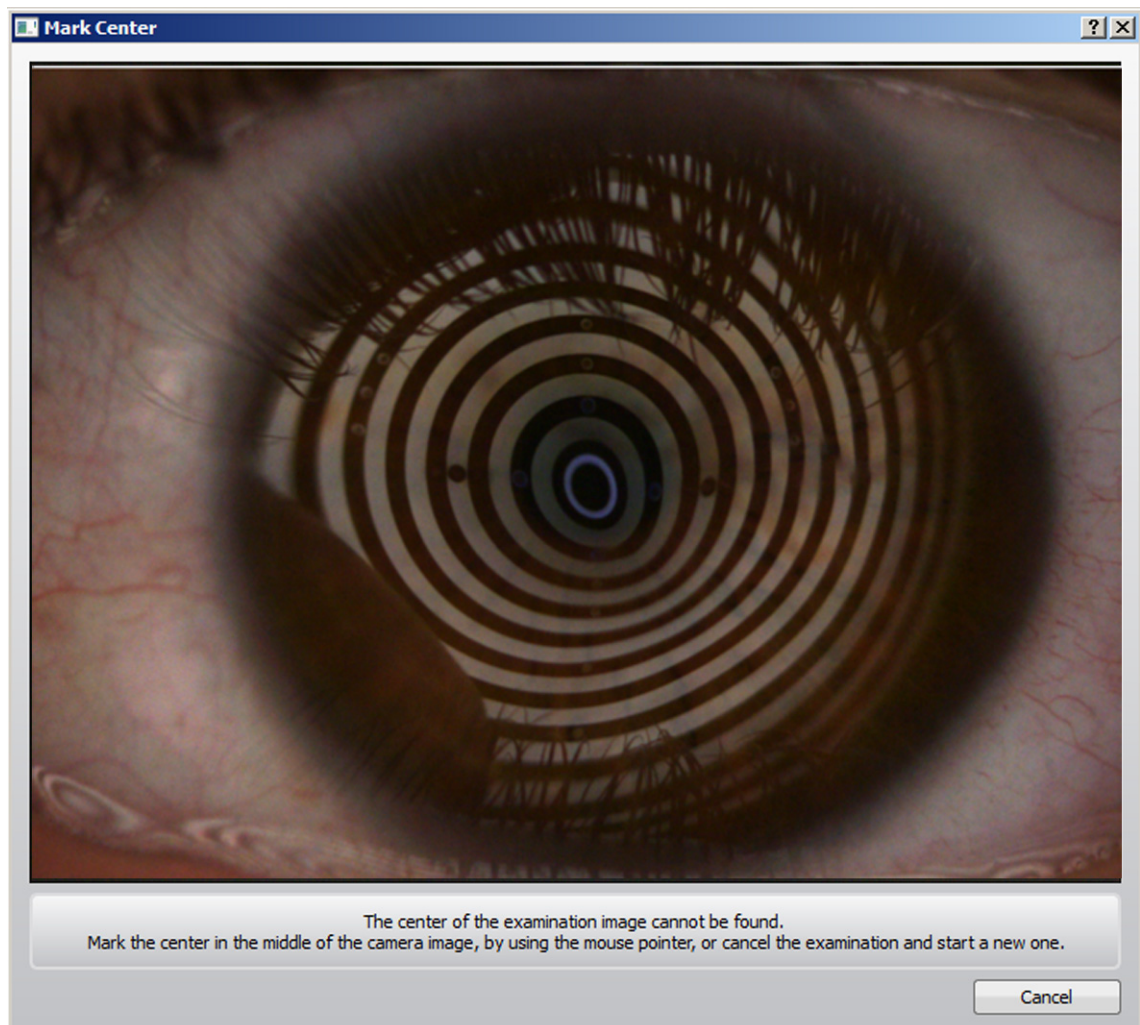

Fig. 10-9: Marking the Placido rings manually

10.8.2 Measuring the Back Surface of a Contact Lens

The procedure for measuring the back surfaces of contact lenses is similar to that for measuring corneas.

After the contact lens has been secured into place in the contact lens holder, the latter can be put onto the fixation clip (see below).

Mounting Parts

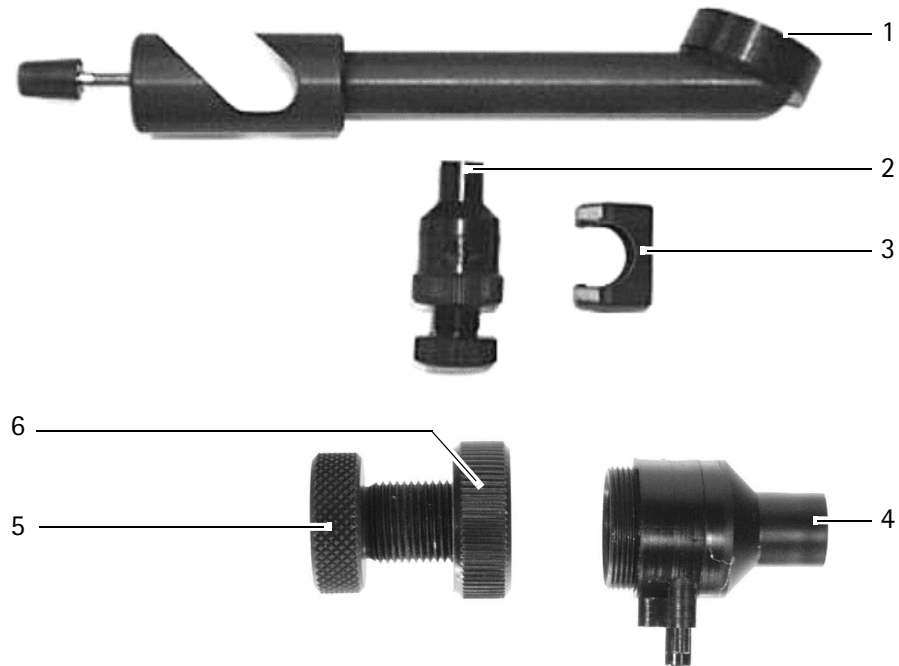

- | | |
|---------------------------|---|
| 1 Reference sphere holder | 4 Magnified view of CL holder (top part) |
| 2 Contact lens holder | 5 Magnified view of CL holder (union nut) |
| 3 Fixation clip | 6 Magnified view of CL holder (adjusting screw) |

Fig. 10-10: Mounting parts for measuring the back surfaces of contact lenses

Fill the Contact Lens Holder with Water

- ➔ Unscrew the union nut to open the contact lens holder.
- ➔ Fill the contact lens holder with water and then close it again with the union nut. Ensure that as little air as possible is trapped inside.
- ➔ Hold the contact lens holder with the adjusting screw pointing downwards.
- ➔ Screw the adjusting screw further into the contact lens holder until the top part of the contact lens holder is completely covered with water.
- ➔ Then unscrew the adjusting screw again until the surface of the water takes on a slightly concave curvature.

Measure the Back Surface of the Dry Contact Lens

- Clean and dry the contact lens that is to be measured with a soft cloth.
- Make sure that there is no moisture, dust or fingerprints on the concave inner surface.

Fixating the Contact Lens

- Pick up the contact lens between your thumb and index finger and carefully place it on the surface of the water in the contact lens holder.
- Unscrew the adjusting screw at the contact lens holder until the contact lens sits securely in the holder.
When doing so, no air bubbles must form and water must not get onto the back surface that is to be measured.

Fasten the Mounted Contact Lens Holder into Place

- Screw the reference sphere into place at the chin rest.
- Put the contact lens holder onto the fixation clip.
- Align the fastening arm so that the optical axes of the contact lens and of the keratograph roughly coincide.

Fully Mounted Contact Lens Holder

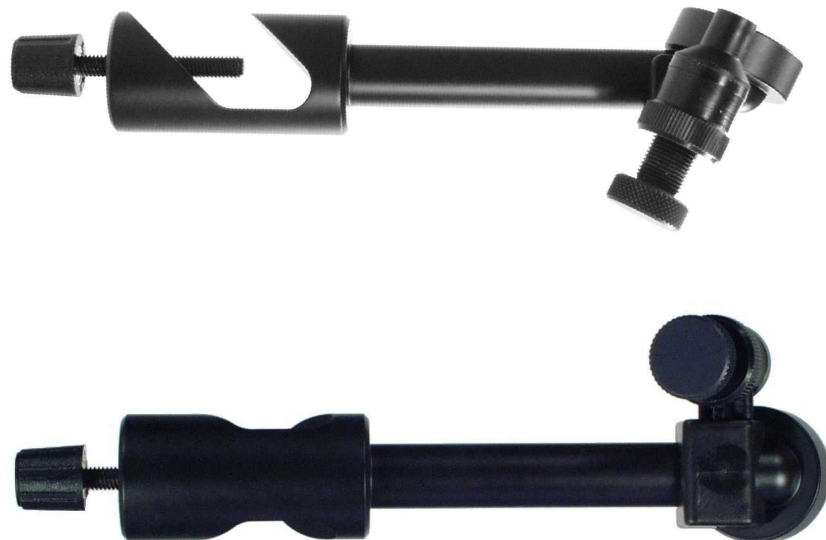
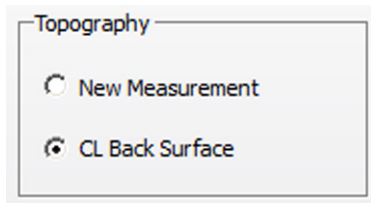

Fig. 10-11: Mounted contact lens holder

Conducting the Measurement with the Keratograph 5M-Software



- ➔ Start the Keratograph 5M-Software ([sec. 10.1, page 24](#)).
- ➔ In the „Examination“ menu, select the menu item [New].
- ➔ Enable the radio button [CL Back Surface].
Measuring now takes place in the same way as the topography measurement ([sec. 10.8, page 33](#)).

10.9 Performing a "TF-Scan" Examination

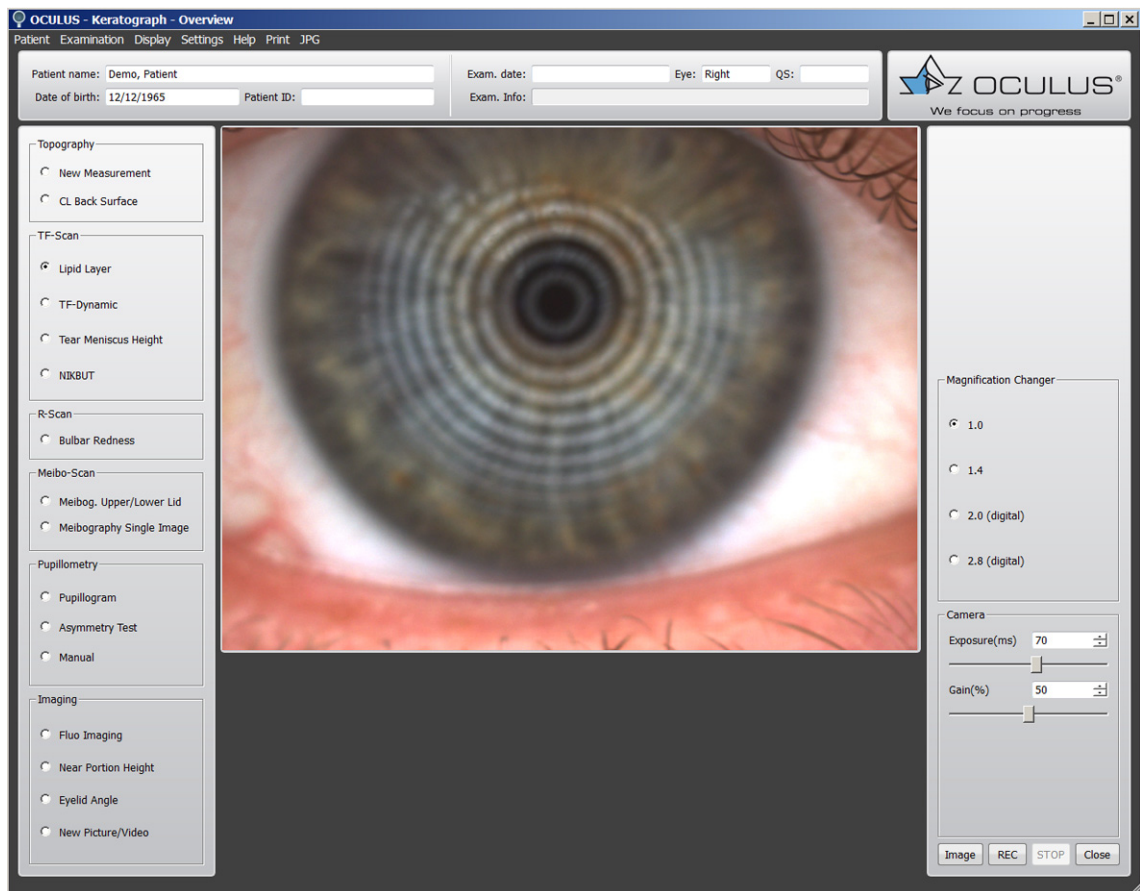
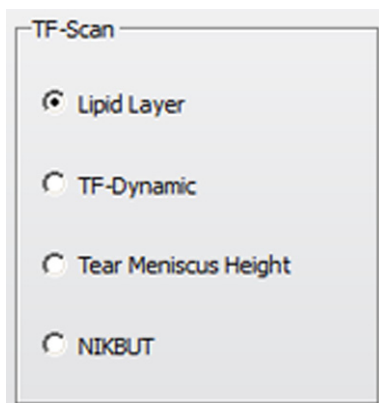

Fig. 10-12: TF-Scan examination, lipid layer example



The TF scan offers the following possibilities, with which you can examine the tear film:

- Lipid layer, [sec. 10.9.1, page 40](#)
- TF dynamic, [sec. 10.9.2, page 41](#)
- Tear meniscus height, [sec. 10.9.3, page 42](#)
- NIKBUT, [sec. 10.9.4, page 43](#)

You can find instructions on the magnification changer in [sec. 10.13.5, page 55](#).

10.9.1 Examination of the Lipid Layer

The interference colors of the lipid layer and its structure are visible and can be recorded.

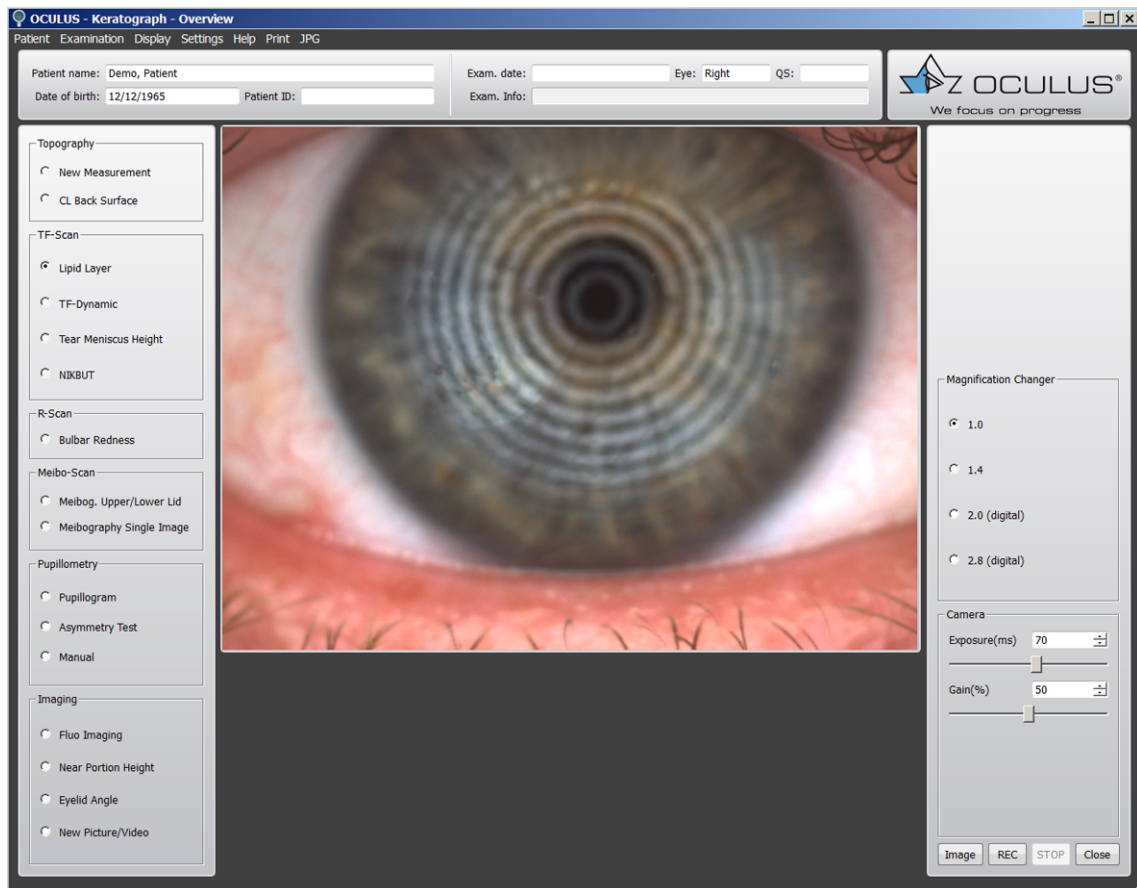

Fig. 10-13: Assessment of the lipid layer

- ➔ Enable the [Lipid Layer] radio button.
- ➔ Move the Keratograph 5M in small increments towards the patient's eye. Now properly focus the Placido rings.
- ➔ Pull the camera back a little and focus on the lipid layer.
- ➔ Press the [Image] button to take a snap shot of the lipid layer, or press the [REC] button to record a video. To stop recording, press the [STOP] button.

Use the foot switch alternatively, [\(sec. 10.6, page 32\)](#).

Recommendation: A video recording is the best way to optimally document the lipid layer.

- ➔ To be able to optimally assess the distribution of the lipid on the surface of the tear film, record the lipid layer for the duration of two to three eyelid blinks.

You can find instructions on the magnification changer in [sec. 10.13.5, page 55](#).

10.9.2 TF-Dynamic Examination

With the video recording (up to 32 frames per second), you can observe the distribution of the particles in the tear film. Based on the flow properties, inferences can be made regarding the viscosity.

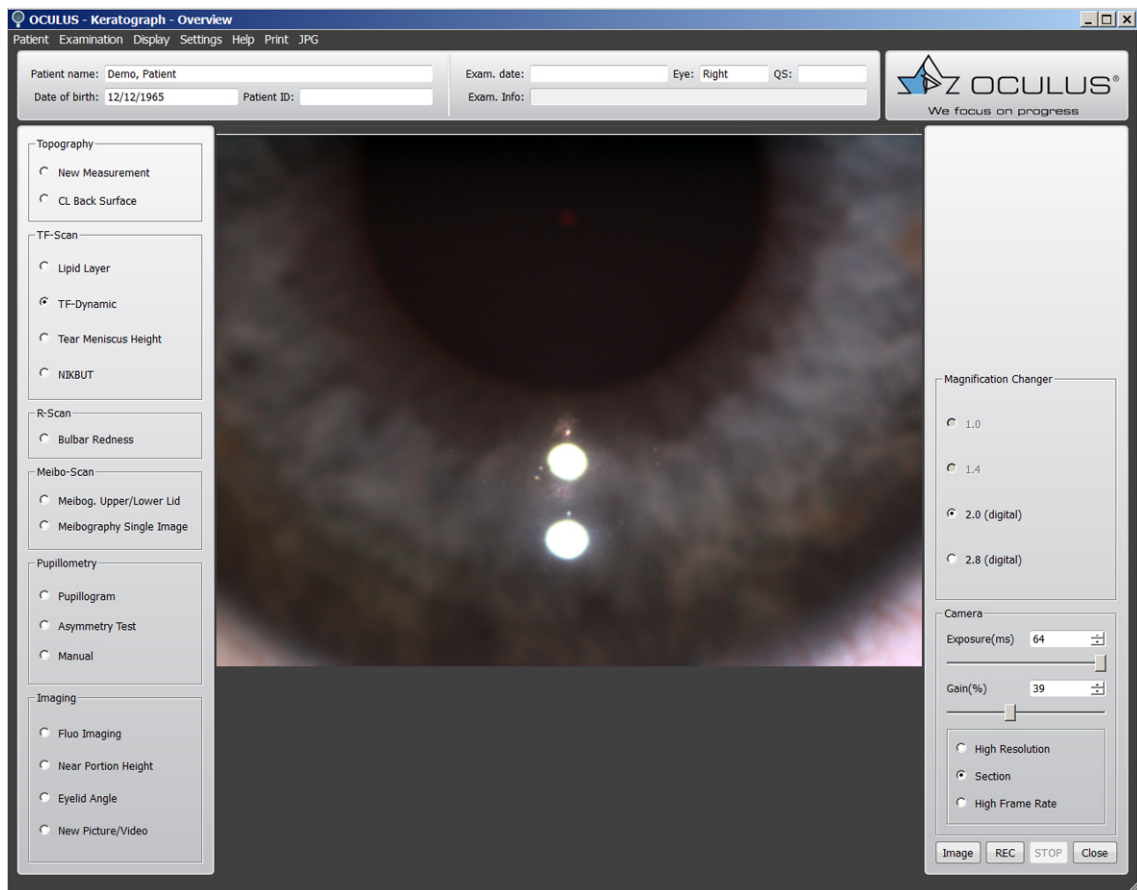

Fig. 10-14: TF-Dynamic assessment

- ➔ Enable the [TF-Dynamic] radio button.
- ➔ Adjust the camera if necessary, [sec. 10.13.5, page 55](#).
- ➔ Focus the light spots. The tear film must be clearly focused.
- ➔ Press the [Image] button to take a snap shot of the particles in the tear film, or press the [REC] button to record a video. To stop recording, press the [STOP] button.
Use the foot switch alternatively, ([sec. 10.6, page 32](#)).

Recommendation: A video recording is the best way to document the tear film dynamic.

- ➔ To be able to assess the flow rate and flow properties of the tear film, as well as the number of particles, record the video for the duration of two to three eyelid blinks.

You can find instructions on the magnification changer in [sec. 10.13.5, page 55](#).

10.9.3 Measuring the Tear Meniscus Height

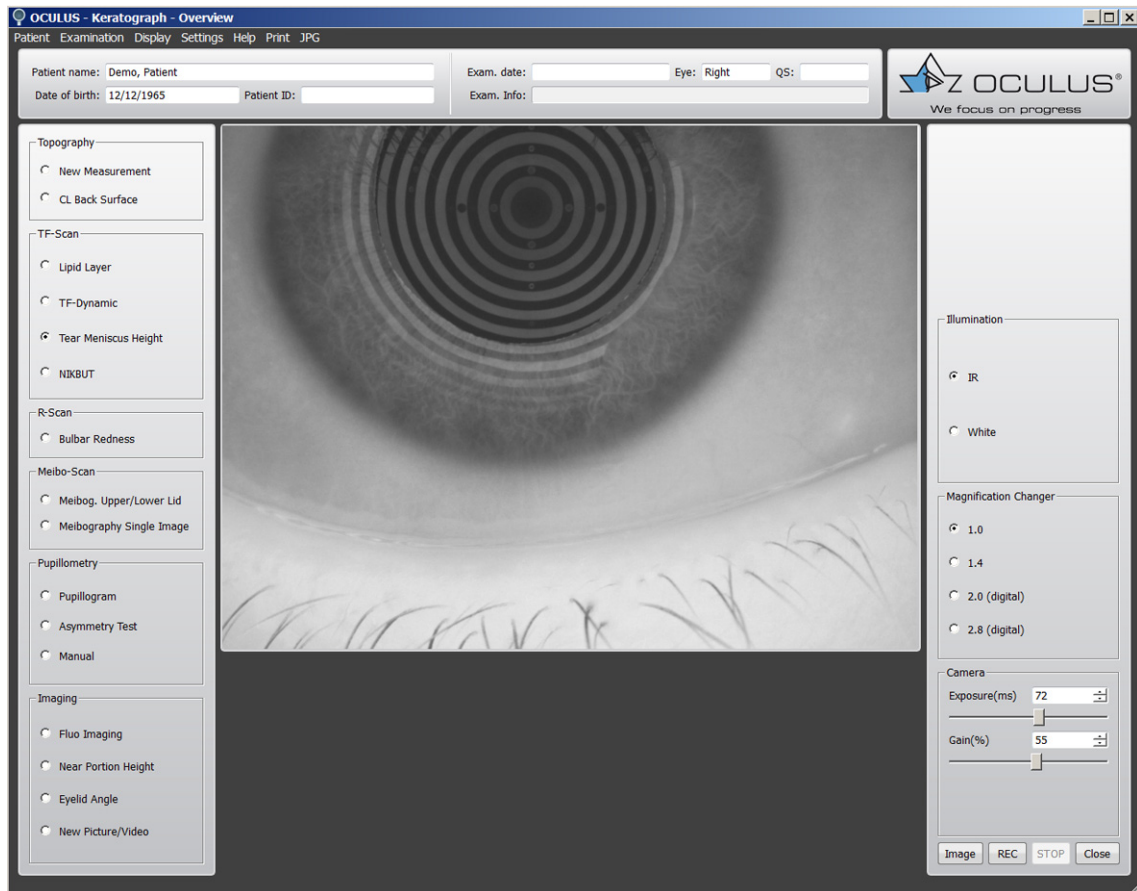

Fig. 10-15: Measurement of tear meniscus

To determine the height of the tear meniscus, it is necessary to measure the tear meniscus height.

- ➔ Enable the [Tear Meniscus Height] radio button.
- ➔ Select [IR] or [White] lighting in the group box on the right.



Infrared light (IR) is not visible to the human eye. The use of this type of illumination for measuring purposes prevents the patient's eye from being dazzled. This, in turn avoids falsification of the measuring results caused by an irritation secretion, which could occur in patients who are sensitive to light.

- ➔ Adjust the camera if necessary, [sec. 10.13.5, page 55](#).
- ➔ Adjust the camera image so that the tear meniscus is centrally displayed.
- ➔ Focus the reflected rings of the tear meniscus height.
- ➔ Press the [Image] button.

You can use the foot switch alternatively, ([sec. 10.6, page 32](#)).

Notes on the magnification changer can be found in [sec. 10.13.5, page 55](#).

10.9.4 Measuring NIKBUT

With the NIKBUT measurement (Non Invasive Keratograph Break-Up Time), the dissolution period of the tear film is determined. Infrared light or white light is used for illumination in this case.

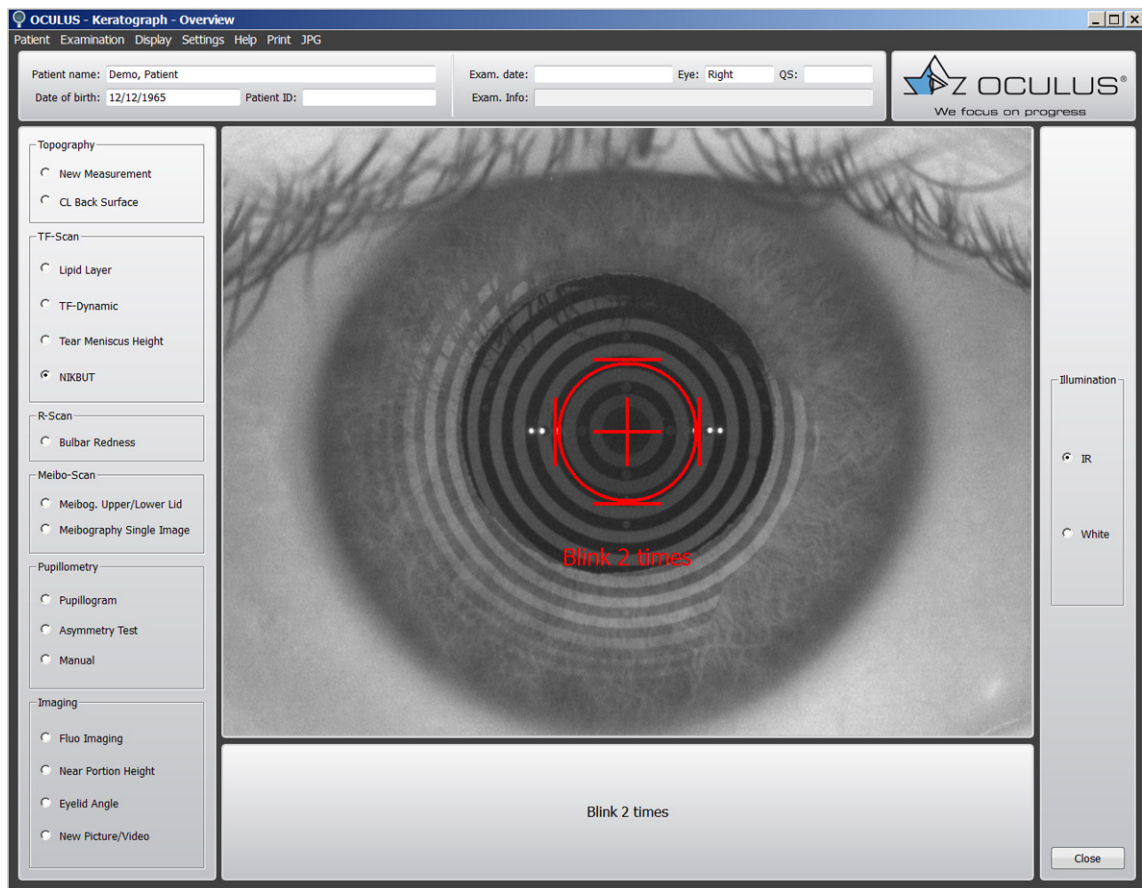

Fig. 10-16: NIKBUT examination

- ➔ Enable the [NIKBUT] radio button on the left in the examination bar.
- ➔ Select [IR] or [White] lighting in the group box on the right.



Infrared light (IR) is not visible to the human eye. The use of this type of illumination for measuring purposes prevents the patient's eye from being dazzled. This, in turn avoids falsification of the measuring results caused by an irritation secretion, which could occur in patients who are sensitive to light.

- ➔ Adjust the camera if necessary, [sec. 10.13.5, page 55](#).
After successful positioning and adjustment this prompt appears: „Blink 2 times“.
- ➔ Ask the patient to blink twice.
The measurement is performed.
- ➔ Please tell the patient to keep his eye open as long as it is comfortable.



Note

The measurement is automatically terminated if the patient blinks, moves strongly, or the tear film significantly breaks up.

10.10 Performing an "R-Scan" Examination

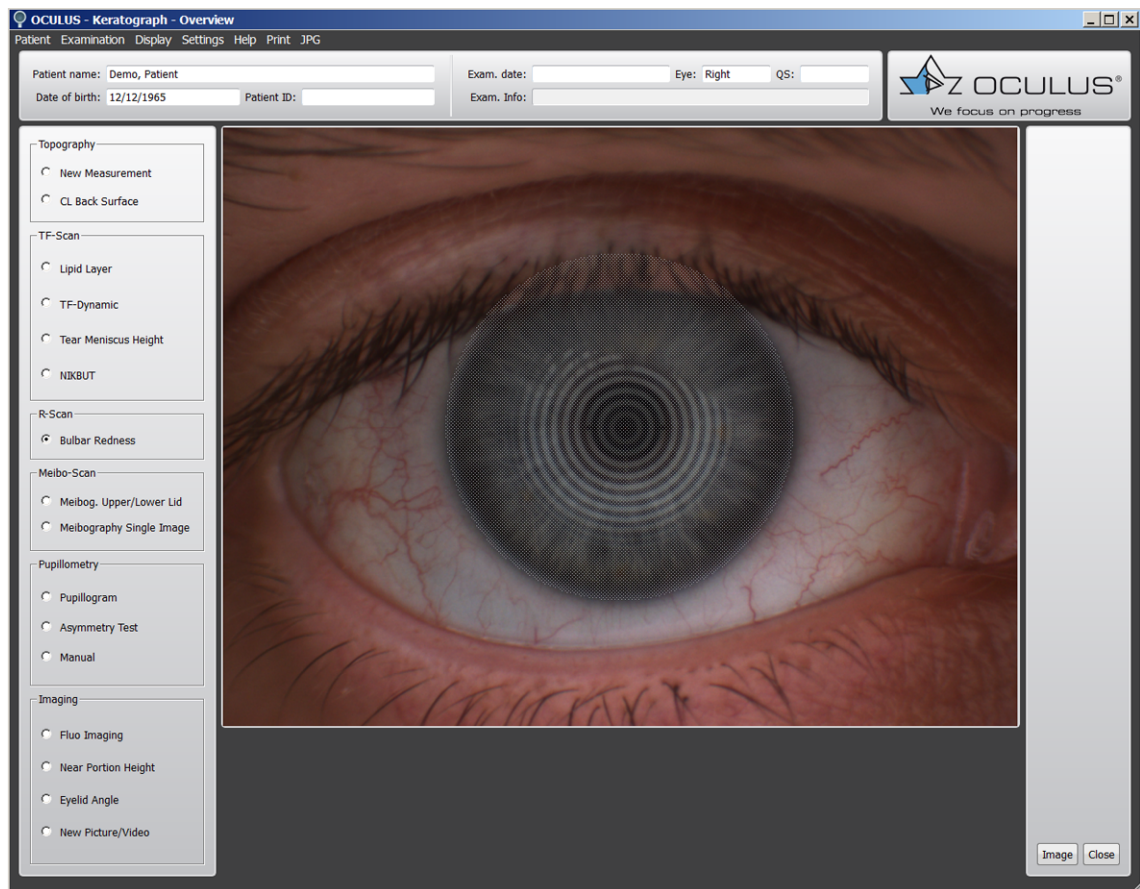
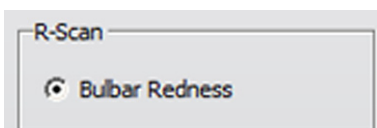

Fig. 10-17: R-Scan examination



With this examination, you can classify levels of redness.

- ➔ Enable the [Bulbar Redness] radio button.
- ➔ Align the camera so that the grey "disc" covers the iris and .
- ➔ Press the [Image] button.

Use the foot switch alternatively, ([sec. 10.6, page 32](#)).

10.11 Performing a "Meibo-Scan" Examination

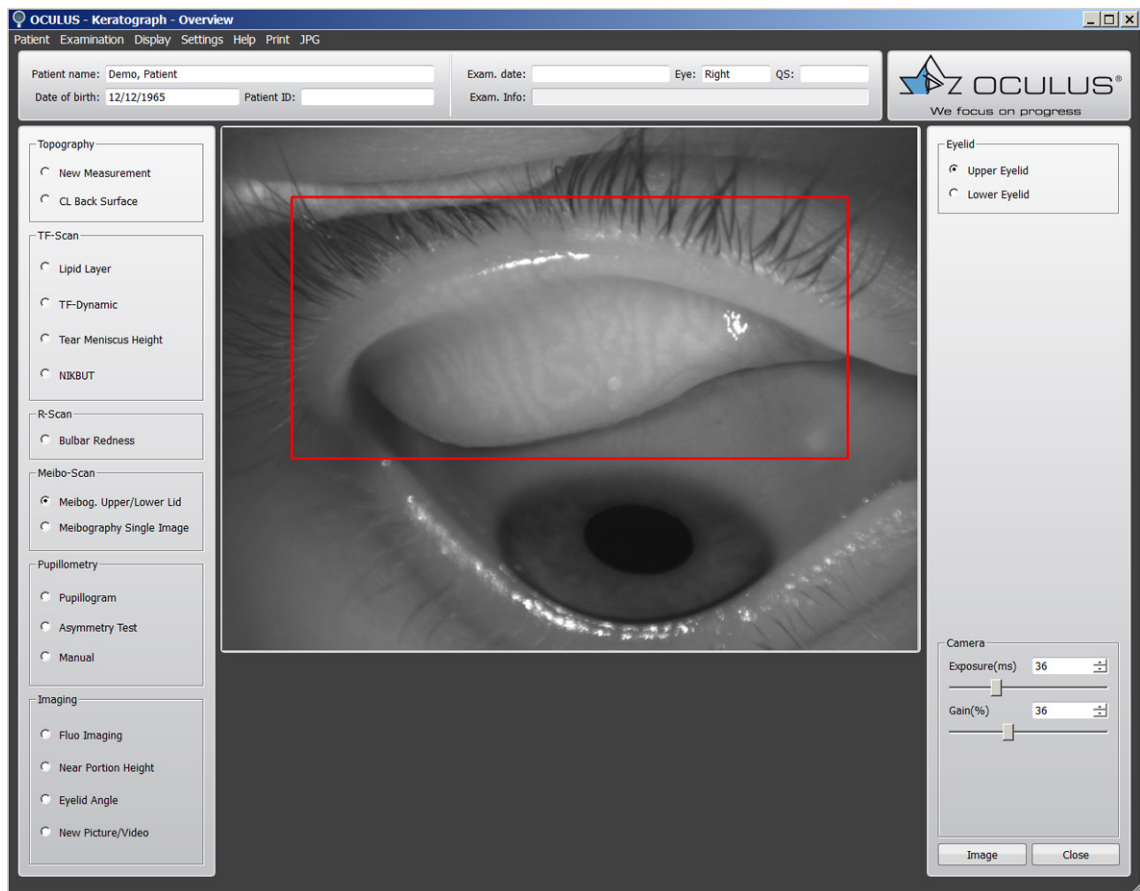
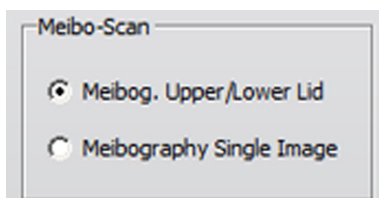

Fig. 10-18: Meibo-Scan examinations

This examination visualizes the meibomian glands. They are displayed three-dimensionally. You can make images of the upper and lower eyelid, as well as, individual images. Changes can be viewed and documented.

Upper and Lower Eyelid Image



- ➔ Enable the [Meibog. Upper/Lower Lid] radio button in the right group box [Meibo-Scan].
- ➔ Invert the upper eyelid first.
- ➔ Adjust the camera if necessary, [sec. 10.13.5, page 55](#).
- ➔ Position the camera so that the upper eyelid fits in the red-framed recording box.
- ➔ Focus on the meibomian glands.
- ➔ Start the recording of the upper eyelid. For this, press the [Image] button.
Use the foot switch alternatively, ([sec. 10.6, page 32](#)).
- ➔ Repeat the steps for the lower eyelid.

Recording a Single Image

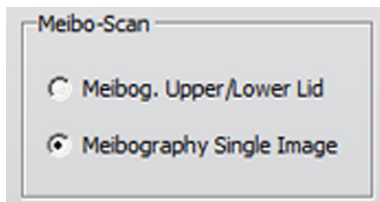

- ➔ Enable the [Meibography Single Image] radio button.
- ➔ Invert the upper or lower eyelid.
- ➔ Position the camera so that the upper or the lower eyelid fits in the red-framed recording box.
- ➔ Focus on the meibomian glands.
- ➔ Start the recording. For this, press the [Image] button. Use the foot switch alternatively, ([sec. 10.6, page 32](#)).

10.12 Performing a "Pupillometry" Examination

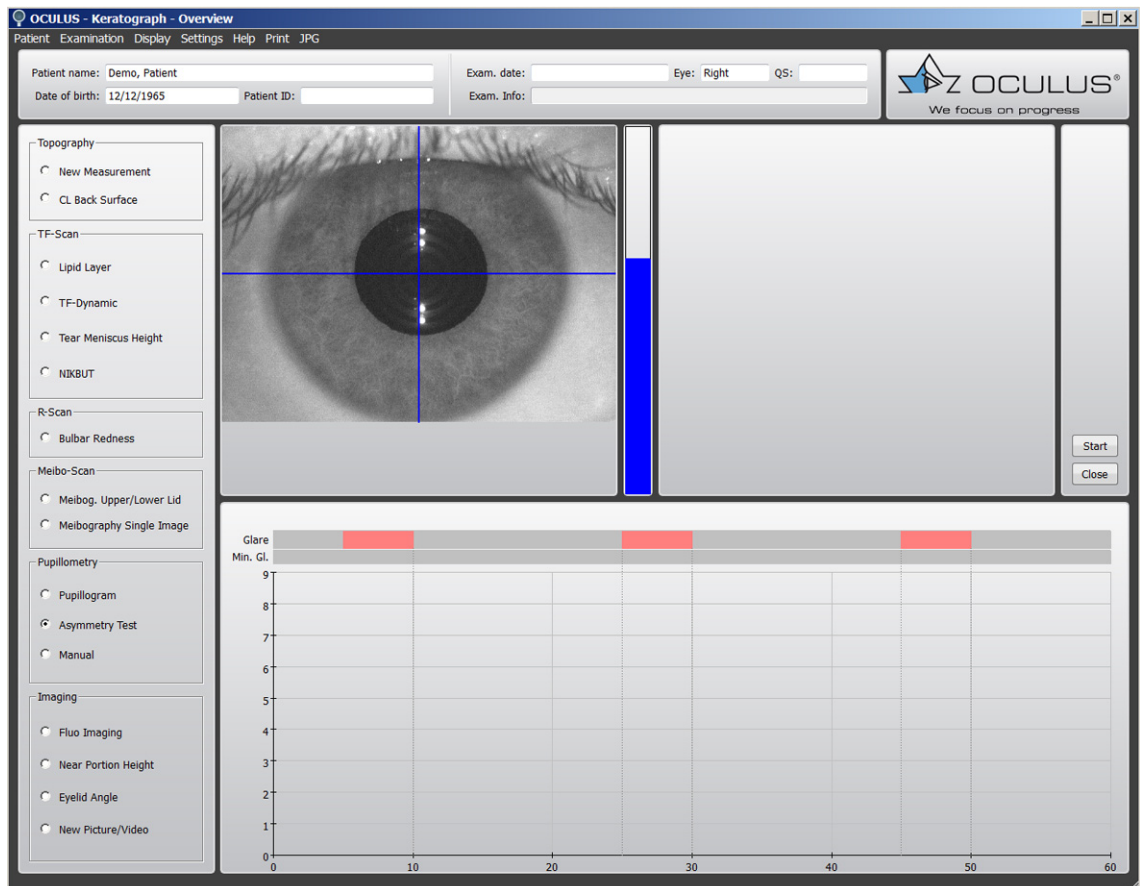
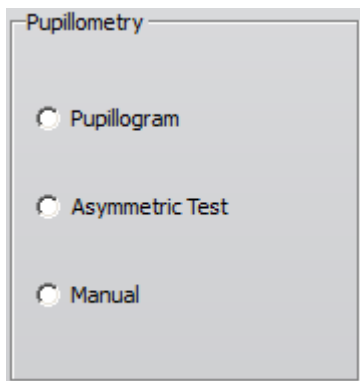

Fig. 10-19: Examination Pupillometry



With this function, you continuously examine the pupil size dependent on different glare states.

- ➔ Select the required measuring program. To do so, enable the appropriate radio button:
- Pupillogram, [sec. 10.12.3, page 49](#)
 - Asymmetric test, [sec. 10.12.4, page 49](#)
 - Manual, [sec. 10.12.5, page 49](#)

10.12.1 Adjustment

To use the pupillometry function, you must first focus the image.

- ➔ Use the adjusting base ([sec. 10.3.2, page 27](#)) and the joystick to focus on the center of the pupil.
- ➔ Use the image sharpness to adjust the distance.
To do so, sharply focus the image of the pupil by moving the x-y stage or the joystick towards the Keratograph or away from the Keratograph.

The blue bar gives an indication of the sharpness of the camera image. The higher the blue bar, the sharper the camera image is.

10.12.2 Diagram

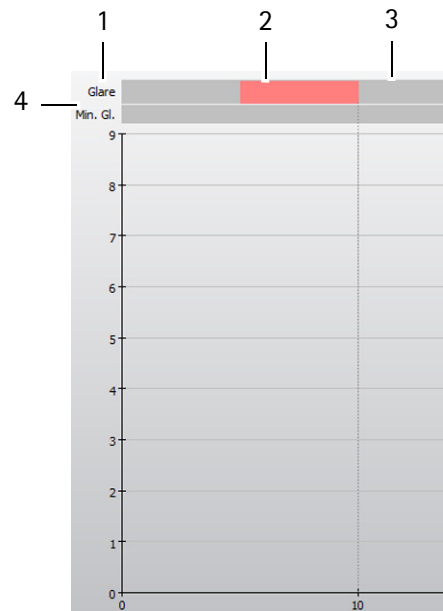

- 1 "Glare" bar
- 2 Red marker
- 3 Gray marker
- 4 "Min. Gl." bar

Fig. 10-20: Diagram

The measured values are displayed as a diagram.

Glare (1): Indicates the status of the ring illumination (Placido system).

Red markers (2): "Glare on",

Gray markers (3): "Glare off"

Min. Gl.: indicates the status of the inner ring. The glare intensity is much weaker.

10.12.3 Pupillogram

Automatic, standard pupillometry program.

0.2s Glare, then 9.8s rest period (5 times).

- ➔ Enable the radio button [Pupillogram].
- ➔ Focus the image.
- ➔ Press the [Start] button to start the measurement.

The measurement automatically comes to an end after 60 seconds. You can end the measurement manually by pressing the [Stop] button.

The measurement is saved and the next screen appears automatically, refer to the [User Guide](#).

10.12.4 Asymmetric Test

Automatic pupillometry program for detection of a pupillary difference.

5s Glare, then 15s rest period (3 times)

- ➔ Enable the radio button [Asymmetric Test].
- ➔ Focus the image.
- ➔ Press the [Start] button to start the measurement.

The measurement automatically comes to an end after 60 seconds. You can end the measurement manually by pressing the [Stop] button.

The measurement is saved and the next screen appears automatically, refer to the [User Guide](#).

10.12.5 Manual

The glare states are set manually.

- ➔ Adjust the glare intensity by pressing the [Glare] and [Min. glare] buttons accordingly. In this program, you set the glare manually (in contrast to the automatic programs).

[Glare] button: Switches the entire ring system on or off.

[Min. glare] button: Switches the inner ring of the ring system on or off.

The stimulus intensity of [Min. glare] is much lower than that of [Glare].

The measurement ends automatically when the measurement reaches the right side of the diagram.

Alternatively, you can end the measurement by pressing the [Stop] button.

When the measurement has ended, the Overview screen automatically opens.

10.13 Imaging

With the imaging software and the high-resolution color camera, you can record videos and create image files to document clinical findings of the eye, or you can conduct special measurements for the adaptation of contact lenses and for checking their proper fit, with or without fluorescein.

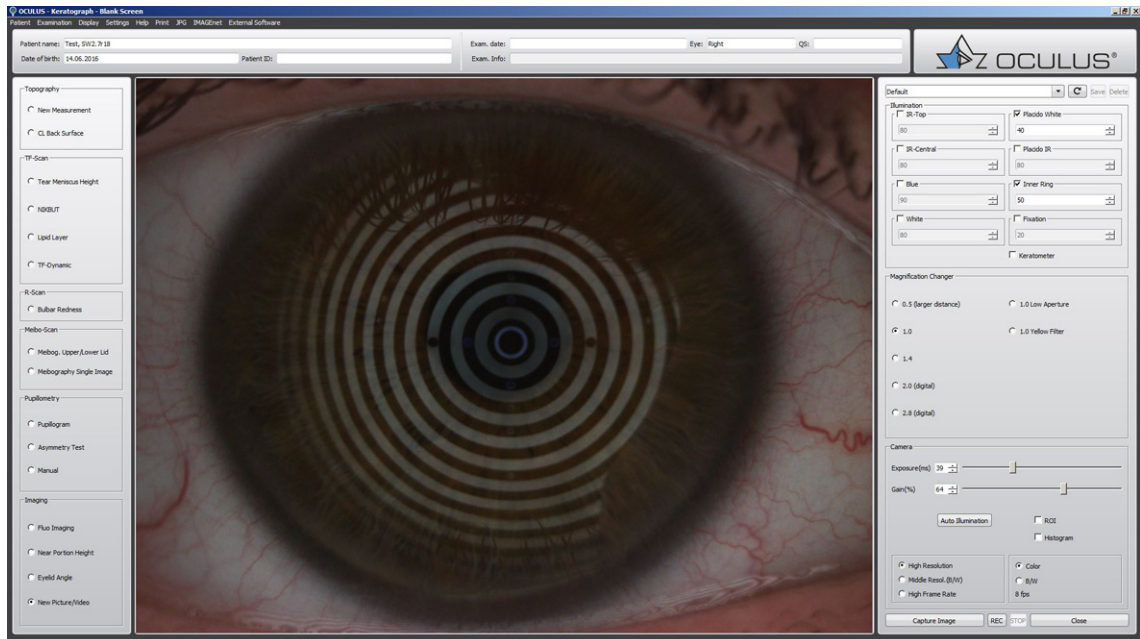
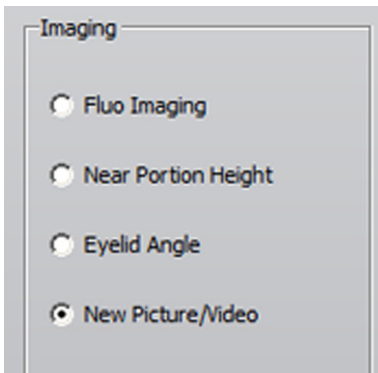

Fig. 10-21: Examinations with "Imaging"



➔ Select the desired recording type. To do this, enable the appropriate radio button:

- Record fluo image, [sec. 10.13.1, page 51](#)
- Measure near portion height, [sec. 10.13.2, page 52](#)
- Eyelid angle measure, [sec. 10.13.3, page 53](#)
- New recording, [sec. 10.13.4, page 54](#)

10.13.1 Recording a Fluo Image

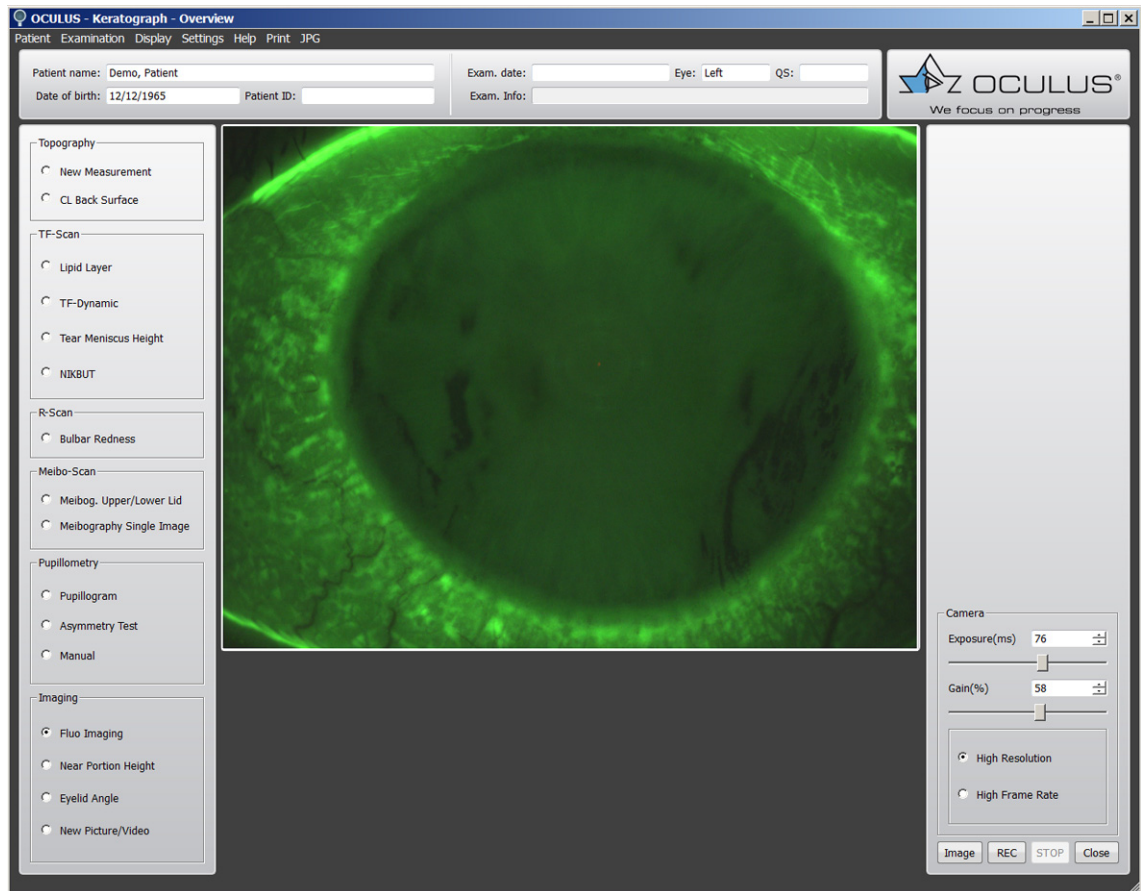

Fig. 10-22: "Fluo imaging" function

- ➔ Enable the [Fluo Imaging] radio button.
- ➔ Adjust the camera if necessary, [sec. 10.13.5, page 55](#).
- ➔ Align the camera to the center of the cornea or contact lens.
- ➔ Press the [Image] button for a static image.
Now you can use the fluo image for example for contact lens fitting, see [User Guide](#).
- ➔ Press the [REC] button to record a video to dynamically check the fit of the contact lens.
Click the [STOP] button to stop or pause the recording.
You can use the foot switch alternatively, ([sec. 10.6, page 32](#)).



The videos or images are stored automatically.

- ➔ Press the [Close] button and you will reach the overview display.
You can find more information in the [User Guide](#).

10.13.2 Near Portion Height Measurement

The near portion height measurement is used to determine separator positions for bifocals and rigid contact lenses.

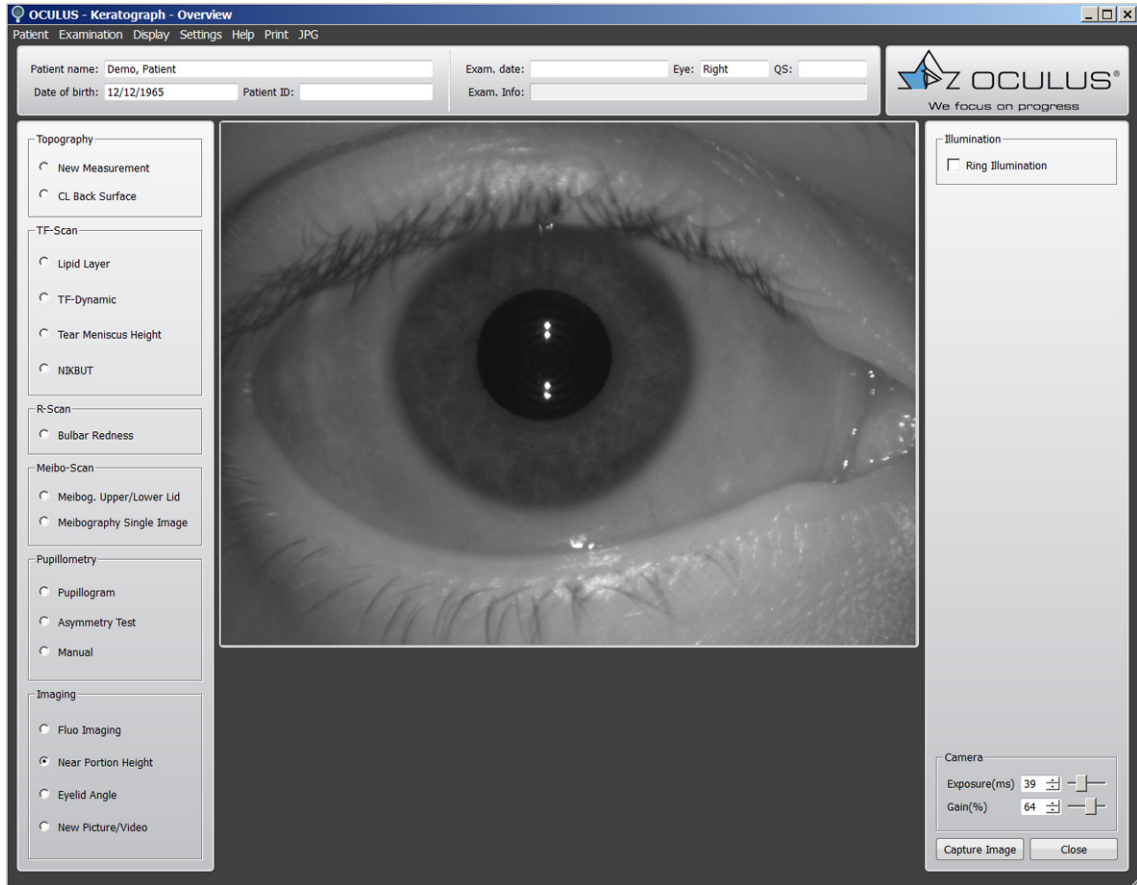

Fig. 10-23: "Near portion height measurement" imaging function

- ➔ Enable the [Near Portion Height] radio button.
- ➔ Adjust the camera if necessary, [sec. 10.13.5, page 55](#).
- ➔ Center and focus on the eye in the camera image.
- ➔ Enable the [Ring Illumination] radio button. The lightning will be brighter. The pupil will be smaller.
- ➔ Press the [Capture Image] button to trigger the recording.
Use the foot switch alternatively, ([sec. 10.6, page 32](#)).



The image is stored automatically.

Press the [Close] button and you will reach the next display.

Perform the near part height measurement and evaluation, see [User Guide](#).

10.13.3 Eyelid Angle Measurement

The measurement of the nasal lower lid angle is required for the fitting and accurate calculation of toric soft lenses.

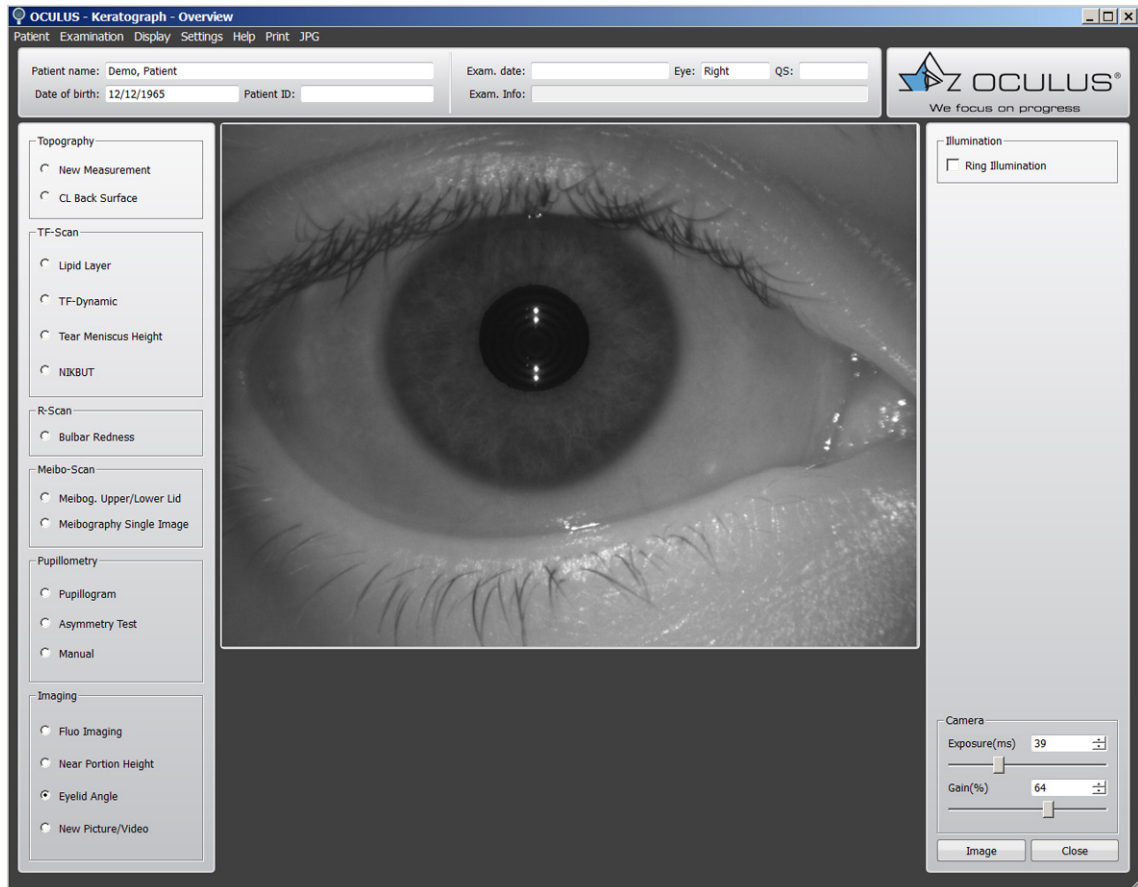

Fig. 10-24: "Eyelid angle measurement" imaging function

- ➔ Enable the [Eyelid Angle] radio button.
- ➔ Adjust the camera if necessary, [sec. 10.13.5, page 55](#).
- ➔ Center the eye in the camera image.
- ➔ Press the [Image] button to trigger the recording.
Use the foot switch alternatively, ([sec. 10.6, page 32](#)).

The image is stored automatically and you will reach the next display.

Perform the Eyelid angle measurement, see [User Guide](#).

10.13.4 New Recording

This allows you to make additional photos and videos for image documentation.

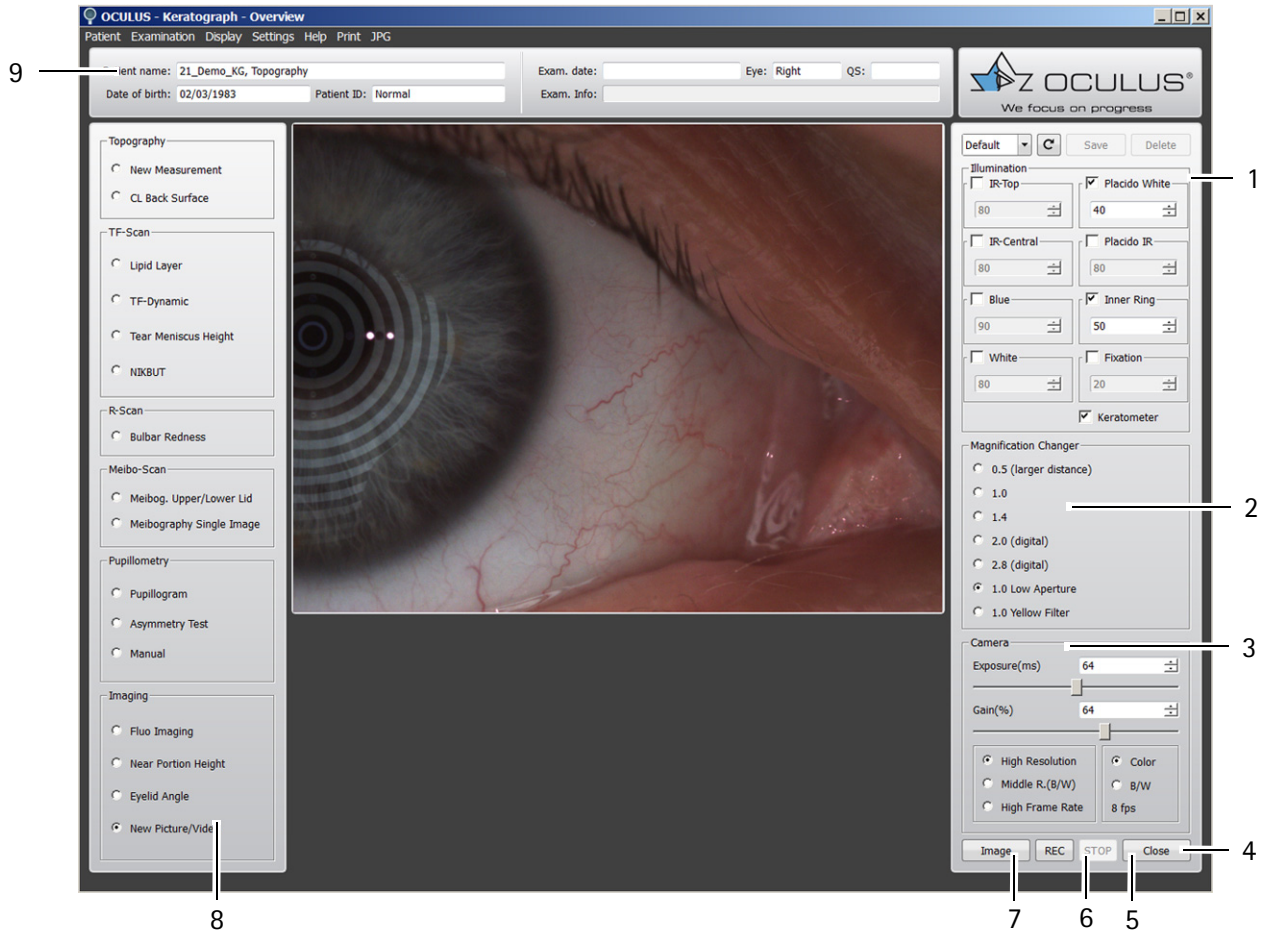

- 1 Illumination settings
- 2 Magnification changer
- 3 Camera settings
- 4 [Close] button
- 5 [STOP] button
- 6 [REC] button
- 7 [Image] button
- 8 Examination bar
- 9 Examination and patient data

Fig. 10-25: "New recording" overview

➔ Adjusting the camera see [sec. 10.13.5, page 55](#).

10.13.5 Adjusting Illumination, Magnification Changer and Camera

For some measurements, the "Illumination", "Magnification Changer" and "Camera" groupboxes appear. You can set values for illumination, magnification changer and camera. You can save the settings as a program.



The optimal camera and illumination settings have already been preset for the selectable measuring functions.

Adjust Illumination: Illumination groupbox

:

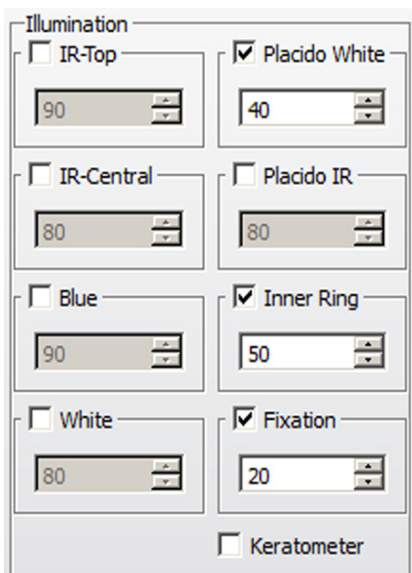

➔ Enable the corresponding radio button to set the desired value.

IR-Top/IR-Central: If only the "IR-Top" and "IR-Central" checkboxes are enabled (in a darkened room):

The fit of the contact lens can be evaluated with the pupil dilated (e.g. for fitting multi-focal lenses).

Blue: The blue light is used for excitation of the fluorescein to fluorescence.

White: TF-Dynamic: Two spots in the bottom segment of the Placido bowl are set to white.

Placido White: Topography and NIKBUT examination: The illumination of the Placido bowl is set to white.

Placido IR: The lighting of the Placido bowl is set to infrared.

Inner ring: The patient's eye is subjected to minimal glare.

Fixation: Used to assist the patient's fixation.

[Keratometer] checkbox: Keratometry marks for aligning the topography

Adjusting magnification: Magnification Changer groupbox

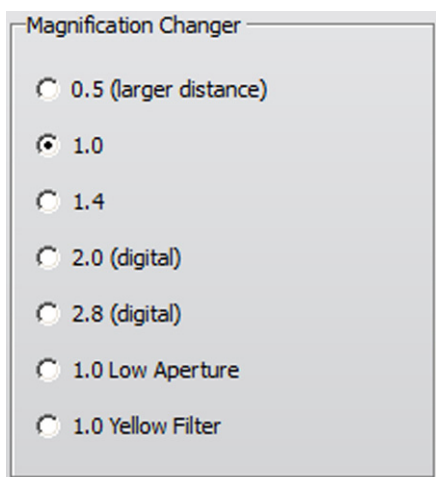

You can set the magnification in this group box. You have a choice of three optical and two digital zooms.

- 0.5 to 1.4
- 2.0 (digital)
- 2.8 (digital)
- 1.0 low aperture, for greater depth of field
- 1.0 yellow filter, for images taken with fluorescein

Adjusting the Camera: Camera groupbox

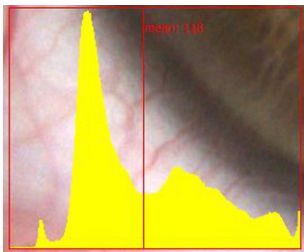
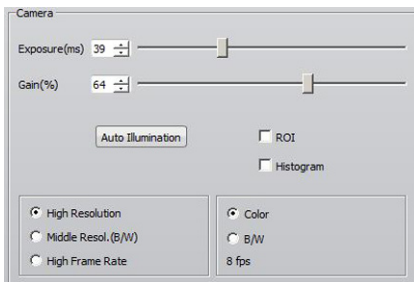

Exposure time: The longer the exposure time, the brighter the image will be. The image can, however, become less sharp as a result.

→ Change the exposure time using the slider control.

Gain: If you increase the gain value, the picture brightens. However, the image quality suffers as a result; too much gain results in grainy images.

→ Change the gain setting on the slider control.

Auto Illumination: You can adjust the illumination with this function, e.g. so as not to overexpose an image.

→ Press the button [Auto Illumination].

You can now adjust the illumination for the entire image capture.

ROI: (Region of Interest); the illumination for a defined region of the image is adjusted.

→ Activate the checkbox [ROI].

→ Move the cursor to the desired position and click on the left mouse button.

You can now adjust the illumination for the selected region.

Histogram: Depending on what has been selected, a histogram is displayed for the entire image or just for the ROI.

The illumination is properly adjusted when the peak on the graphic lies on the red centre line.

High Resolution, Middle R. (B/W) or High Frame Rate: Details will be more visible at a higher resolution, high frame rates provide "smooth" videos.

Color or B/W: Choose color or black and white display.

fps: frames per second

Buttons

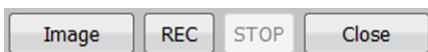

REC/STOP: You start or stop the video recording with these buttons.

Limit the duration of the recordings to maximum one minute, otherwise the volume of data on your computer will become too extensive.

Image: With this button you take a single image. You can, for example, record static fluo images.



Note

The video recordings and single images are saved automatically.

Selecting and saving settings

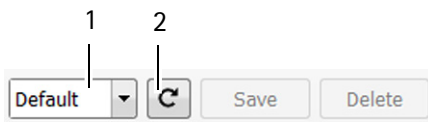

You can use default settings and you can save your own settings as an image program.

Using default settings

- ➔ In the drop down list select the „Default“ program (1).
Default: default settings
XXX: your own saved settings

Using your own settings for an image program

- ➔ Select the settings.
- ➔ Enter the name of the program.
- ➔ Press the [Save] button.

If you press the button (2), the image program uses the saved settings.

If you press the [Delete] button, you delete the image program. You cannot delete the default settings.

10.14 Performing Dry Eye Examinations JENVIS Dry Eye Report

You can perform Dry Eye examinations in the JENVIS Dry Eye Report. The results are summarised in a clear and understandable manner. You can also print a report with the results and explanations for the patient.

- ➔ Select the [New JENVIS Dry Eye Report] menu in the "Examination" menu bar.

The following screen page appears.

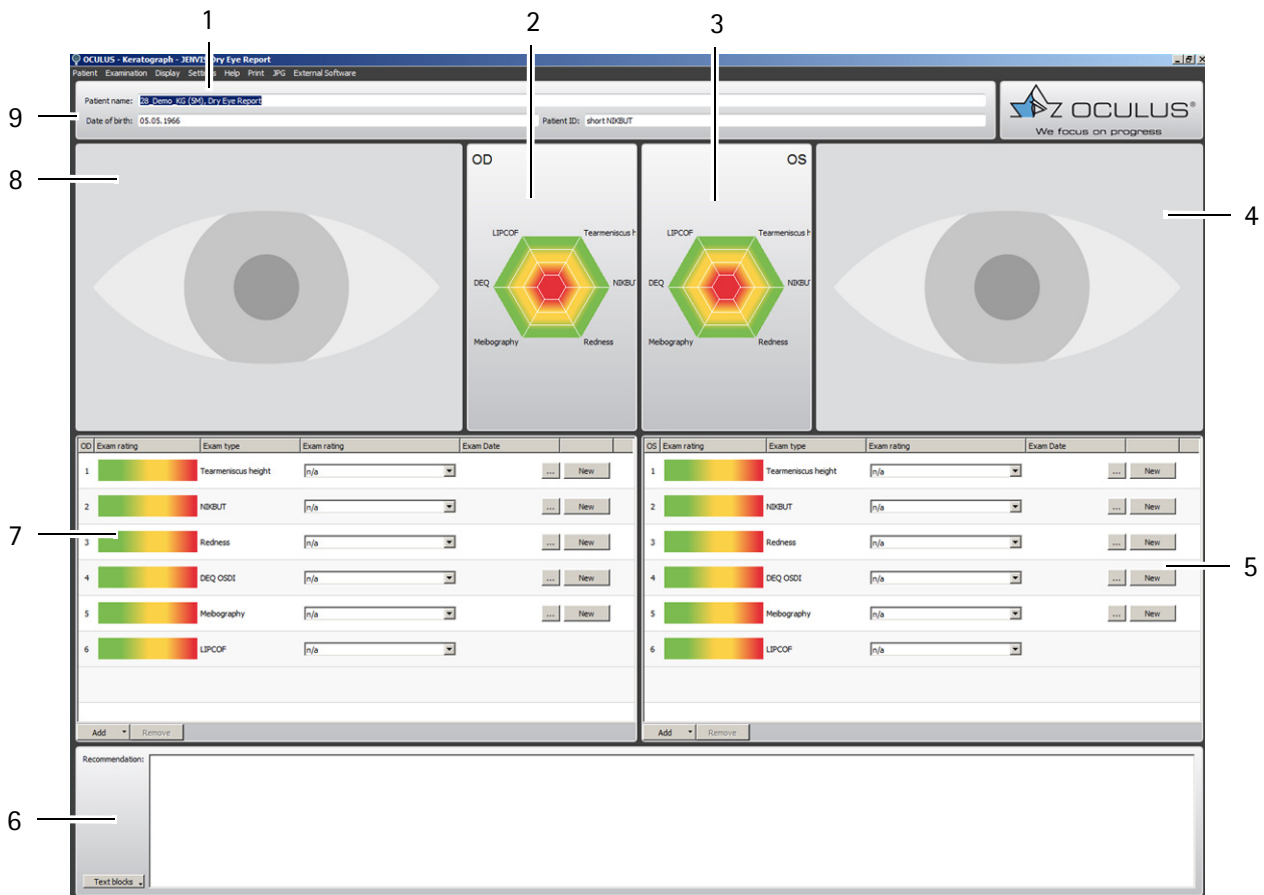

- | | |
|--|---|
| <ul style="list-style-type: none"> 1 JENVIS Dry Eye Report menu bar 2 Result diagram for right eye 3 Result diagram for left eye 4 Camera image for left eye (if available) 5 Exam types for left eye | <ul style="list-style-type: none"> 6 "Recommendation" field 7 Exam types for right eye 8 Camera image for right eye (if available) 9 Patient and examination data |
|--|---|

Abb. 10-26: Overview Display of Dry Eye examinations

10.14.1 Selecting the Exam Type

Exam type

Tearmeniscus height

NIK BUT

Redness

DEQ OSDI

DEQ McMonnies

Meibography

LIPCOF

You can choose from six standard exam types for the right and left eye respectively. Load the required examination or enter a value.

- ➔ Select the desired exam type by clicking on the [New] button or choosing a value from the drop down menu.

You can select further exam types. For more information, refer to the [User Guide](#).

10.14.2 Performing the selected examination

- ➔ Perform the selected examination. The respective examination is performed similar to the examinations already described.
 - Tear meniscus height, [sec. 10.9.3, page 42](#)
 - NIKBUT, [sec. 10.9.4, page 43](#)
 - Redness, [sec. 10.10, page 44](#)
 - DEQ OSDI, [sec. 10.14.5, page 62](#)
 - Meibo-Scan, [sec. 10.11, page 45](#)
 - LIPCOF, [sec. 10.14.6, page 63](#)

The latest measurement result is shown as a blue dot in the menu bar (2).

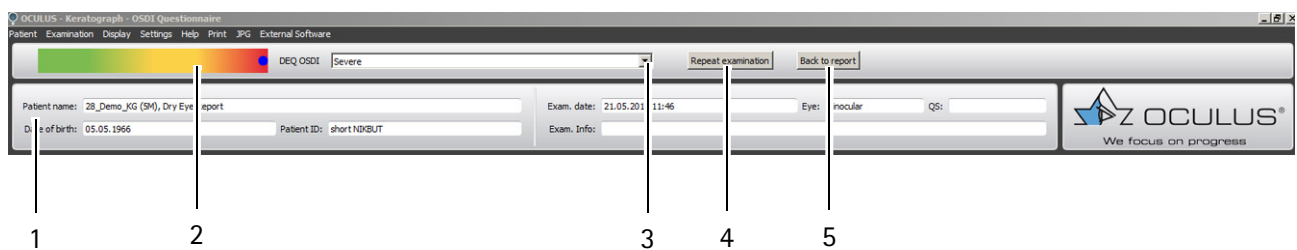

1 Patient and examination data

2 Color bar for measurement result

3 Drop down list for measurement result

4 [Repeat examination] button

5 [Back to report] button

Abb. 10-27: JENVIS Dry Eye Report menu bar

- ➔ If measurement was correct: Click on the [Back to report] button (5) to return to the overview display. After performing a redness examination, the image of the eye is shown in the overview display.
- ➔ If measurement has to be repeated: Press the [Repeat examination] button (4).



Recommendation:

- Always perform all given examinations to receive a complete hexagram.
- Fill in the "Recommendation" field so that the patient receives the respective information, [fig. 10.14.3, page 61](#).

For further information on the JENVIS Dry Eye Report and the examinations, refer to the [User Guide](#).

10.14.3 Filling in the „Recommendation“ field

In this field you can insert details which are later shown on the printout. You can use text components.

For more information, refer to the [User Guide](#).

Using Text Blocks

- Click the [Text blocks] button.
- Select the desired text component. This text will be added to the "Recommendation" field.
- Select further text components, if required.

Entering own Texts

- Move the cursor to the "Recommendation" field and enter your own text.

Deleting Texts

- Mark the text which should be deleted with the cursor.
- Press "Del" on the keyboard.
The text will be deleted permanently.

10.14.4 Printing the JENVIS Dry Eye Report

- Select the [Print] menu item.
The print dialog opens.
Select the desired printer.
- Press the [Print] button.
The results of the dry eye examinations will be printed in the JENVIS Dry Eye Report.
After printing, the JENVIS Dry Eye Report is in read-only mode.

For more detailed information on the printout, refer to the [User Guide](#).

10.14.5 DEQ OSDI

The DEQ OSDI (Dry Eye Questionnaire Ocular Surface Disease Index) is a standardised medical history form. The patient is asked about his/her subjective symptoms. The 12 answers result in an OSDI value.

For more information, refer to the [User Guide](#).

➔ Press the [New] button. The DEQ OSDI is displayed.

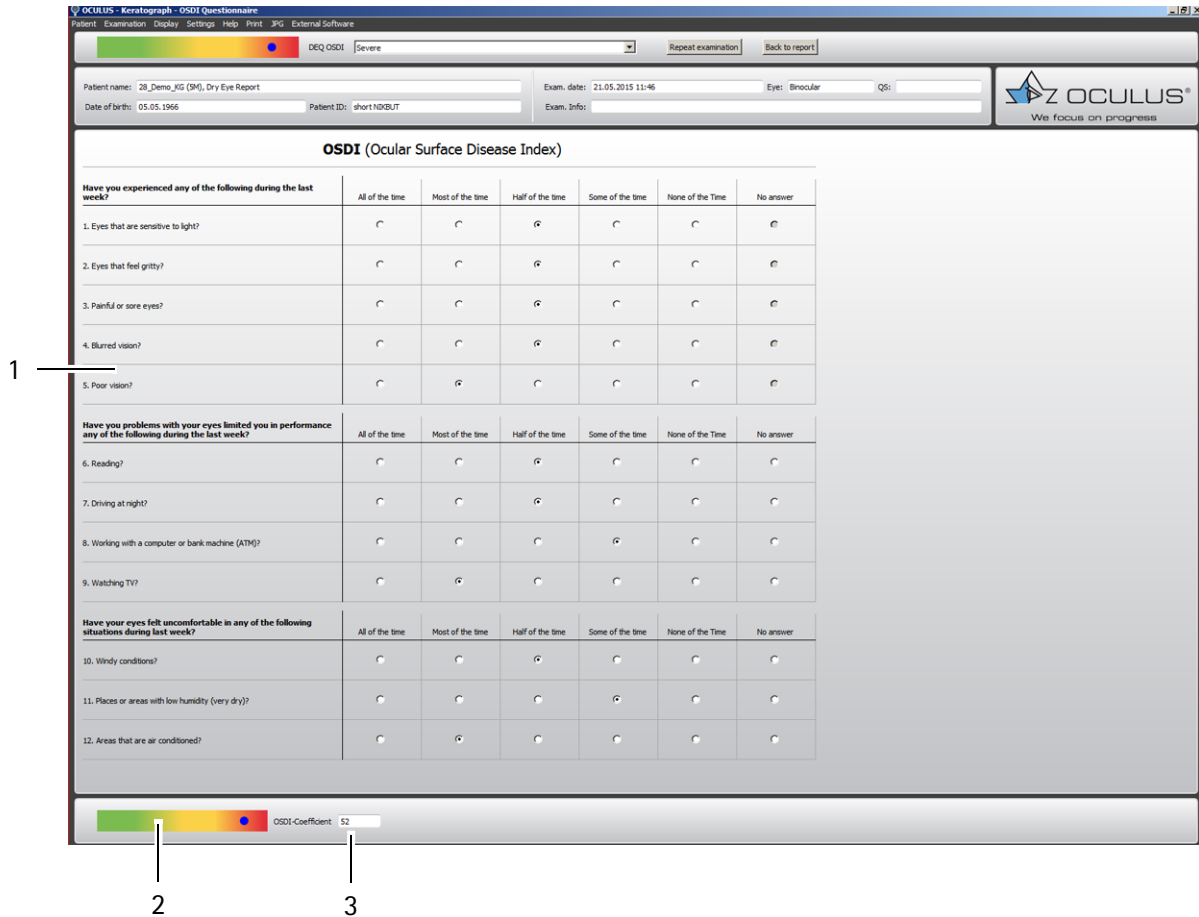

1 Questions

2 Diagram for measurement result

Abb. 10-28: DEQ OSDI screen

3 OSDI coefficient

- ➔ Go through the questions and ask the patient to select the respective answers. The results apply for both eyes.
- ➔ Go back to the overview display by pressing the [Back to report] button. The OSDI value is shown in the assessment field and the diagram.







You can also use the McMonnies Questionnaire instead of the DEQ OSDI. For this, change settings as shown in the [User Guide](#).

10.14.6 LIPCOF

If lid-parallel conjunctival folds (LIPCOF) are present, they can be seen in the vertical slit when examining the temporal lower lid area of the conjunctiva using a slit lamp. Please enter the results here. These results are a further parameter in the assessment of the Dry Eye.

→ Open the drop down list in the Exam rating column.

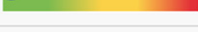
OD	Exam rating	Exam type	Exam rating
1		Tearmeniscus height	Very high (≥0.35 mm)
2		NIKBUT	Very short (<7 seconds)
3		Redness	Mild redness
4		DEQ OSDI	Moderate
5		Meibography	Grade 2: 33% - 67% drop-out
6		LIPCOF	Grade 0: No folds n/a Grade 0: No folds Grade 1: One permanent fold Grade 2: Multiple permanent folds <0.2mm Grade 3: Multiple permanent folds ≥0.2mm

Add Remove

Fig. 10-29: Entering the examination result

→ Select the grade or text which corresponds to the result.

For more information on LIPCOF, refer to the [User Guide](#).

10.15 Performing a JENVIS Pro Dry Eye Report

With the JENVIS Pro Dry Eye Report you perform a complete dry eye workup. It is possible to choose from different worklists like:

- Screening
- Individualized
- Follow-Up
- by DEWS

In every worklist you have a structured workflow which saves time and lets you work more efficiently. You have the liberty however to skip to any position within the worklist.

For each examination the software provides to you additional, supportive information regarding the capturing process (on which area to focus, light adjustment, camera settings etc.).

After you have conducted dry eye workup with a capture worklist, for example Individualized Dry Eye Report, you can evaluate the results in the assessment worklist. In the assessment display the causes of dry eye disease are sorted in sub-categories. You can evaluate every single picture/examination separately, or if you click on a sub headline for example Lid/Margin, all respective examinations pop up on the screen. Based on the assessments which were made it is possible to create a treatment plan with different options to cure the causes of the dry eye disease.

Finally you can create a comprehensive print out (JENVIS Pro Dry Eye Report) which contains all results of the tests, the treatment options and extensive glossary, where all examinations are explained.

- ➔ Select > Examination > New Dry Eye Report > JENVIS Pro > Individualized

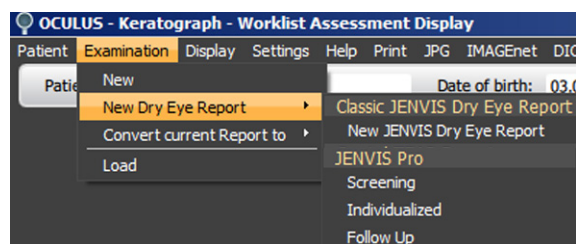
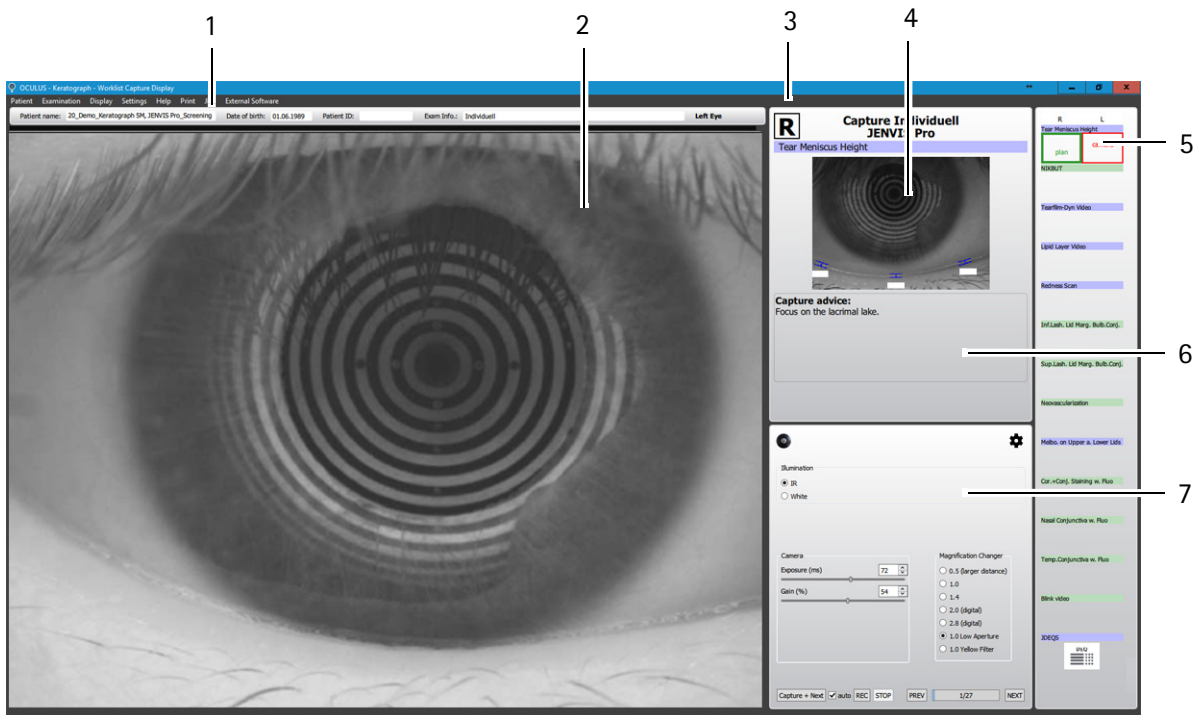

Fig. 10-30: Select Dry Eye report

The following screen appears:



1 Patient/Exam Info

2 Camera live image

3 Currently examined eye

4 Additional supportive information for capturing process

5 Pre-defined examinations

6 Information on measurement

7 Camera/illumination settings

Abb. 10-31: Capture session JENVIS Pro Individualized report

10.15.1 Perform the capture plan based on the worklist

The worklist shows you the first step of the capture plan with the aid of a green and red box. The red box shows the actual camera position and requests you to capture a photo or video.

- ➔ Click on the [Capture] button to perform the requested examination. If the [auto] button is enabled then the [Capture] button is transformed to [Capture + Next]. This means, that after the capturing, the software moves automatically to the next step in the worklist. If you do not want to capture the image you have to click on [Next]. The green box indicates which type of examination will be administered and which of either eyes will be tested.

To work most efficiently the software recommends in which order to capture/examine the right and the left eye consecutively.

It is suggested to start for the Tear Meniscus Height with the right eye and switch then to the left eye. For the NIKBUT the software recommends to start with the left eye and follow with the right eye. For the next three exams you are advised to do all captures of the right eye and switch then to the left eye. If vital dyes like fluorecein have to be instilled contribute all capture items first for one eye and then for the other eye.

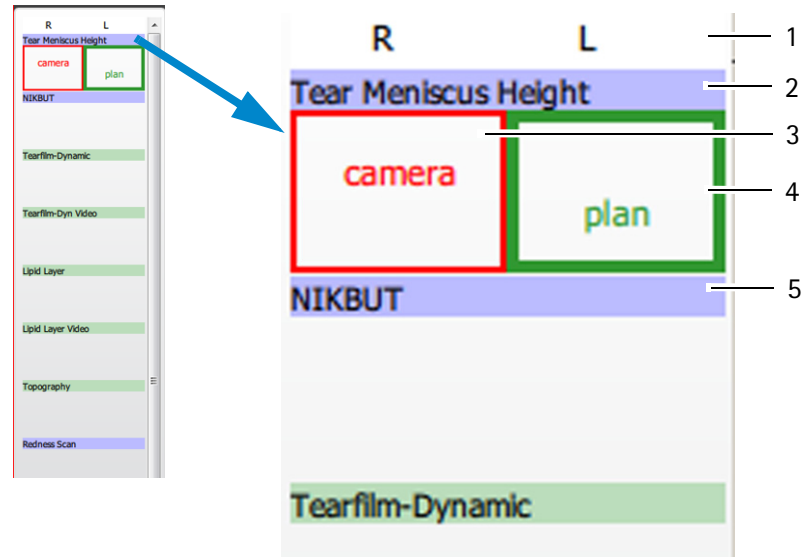

- 1 Right eye/left eye
- 2 Examination
- 3 Current camera position
- 4 Next camera position
- 5 Following examination

Abb. 10-32: Software recommendations

10.15.2 Additional supporting information

This part of the screen supports you in getting the best images for your assessment. The preview picture shows the area of interest for the respective examination. In the field below some capture advices are given for example where to focus the camera, if to use vital dyes or not, how to position the eyelid etc.

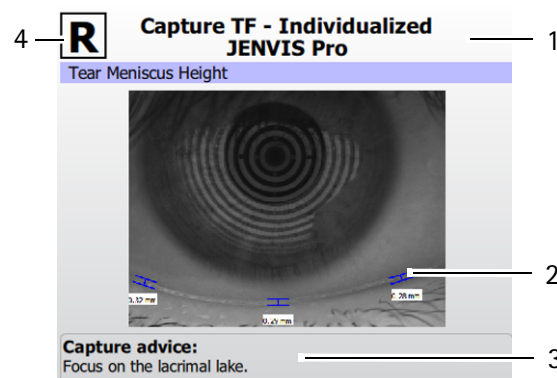

- 1 Capture element of the examination (area of interest)
- 2 Preview picture
- 3 Capture advices
- 4 Right eye/left eye

Fig. 10-33: Additional supporting information

10.15.3 Adjusting Illumination, Magnification Changer and Camera [7]

For some measurements, the "Illumination", "Magnification Changer" and "Camera" groupboxes appear. You can set values for illumination, magnification changer and camera. You can save the settings as a program.



The optimal camera and illumination settings have already been preset for the selectable measuring functions.



Abb. 10-34: Overview illumination and camera settings

Selecting and saving settings

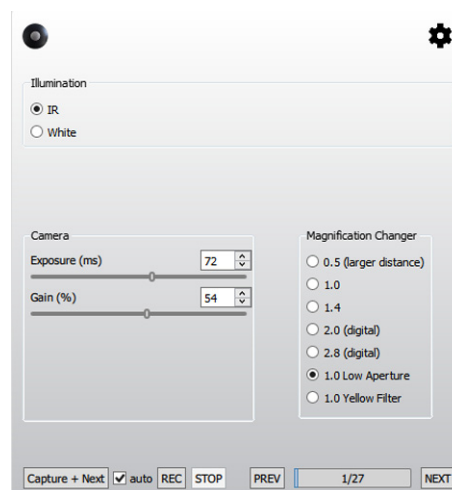
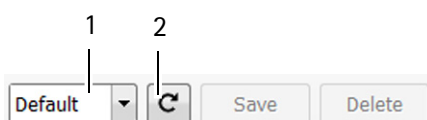

You can use default settings and you can save your own settings as an image program.

Using default settings

- ➔ In the drop down list select the "Default" program (1).
 Default: default settings
 XXX: your own saved settings

Using your own settings for an image program

- ➔ Select the settings.
- ➔ Enter the name of the program.
- ➔ Press the [Save] button.

If you press the button (2), the image program uses the saved settings.

If you press the [Delete] button, you delete the image program. You cannot delete the default settings.

Adjust Illumination: Illumination groupbox

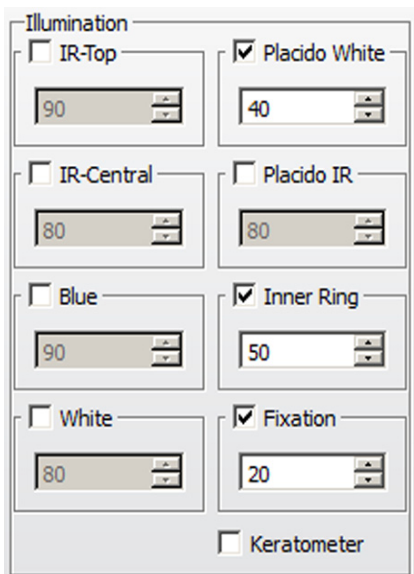

➔ Enable the corresponding radio button to set the desired value.

IR-Top/IR-Central: If only the "IR-Top" and "IR-Central" checkboxes are enabled (in a darkened room):

The fit of the contact lens can be evaluated with the pupil dilated (e.g. for fitting multi-focal lenses).

Blue: The blue light is used for excitation of the fluorescein to fluorescence.

White: TF-Dynamic: Two spots in the bottom segment of the Placido bowl are set to white.

Placido White: Topography and NIKBUT examination: The illumination of the Placido bowl is set to white.

Placido IR: The lighting of the Placido bowl is set to infrared.

Inner ring: The patient's eye is subjected to minimal glare.

Fixation: Used to assist the patient's fixation.

[Keratometer] checkbox: Keratometry marks for aligning the topography

Adjusting magnification: Magnification Changer groupbox

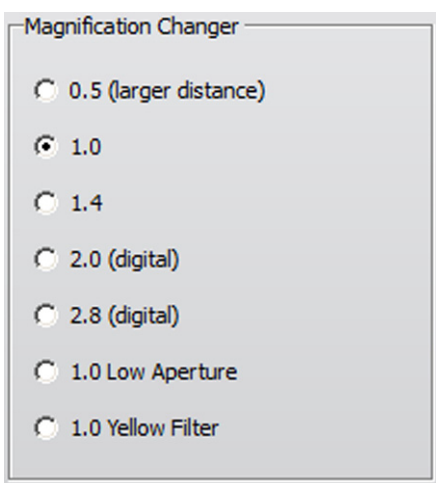

You can set the magnification in this groupbox. You have a choice of three optical and two digital zooms.

- 0.5 to 1.4
- 2.0 (digital)
- 2.8 (digital)
- 1.0 low aperture, for greater depth of field
- 1.0 yellow filter, for images taken with fluorescein

If your device is equipped with a wireless joystick, you can use the joystick to trigger different images.

Modifying Dry Eye Report capture settings: cog icon groupbox



Click this icon to open the "Dry Eye Report Capture Settings" window.

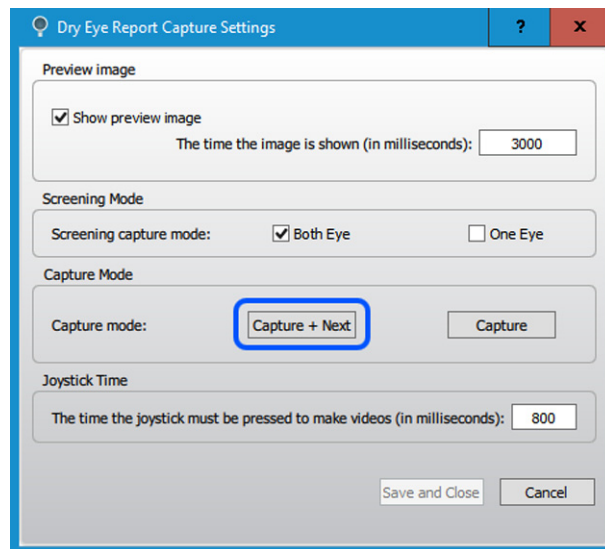

Fig. 10-35: Dry Eye Report capture settings

Preview: Click to enable or disable the preview image and set the display duration time.

Screening mode: Click to determine if both eyes or just one eye should be examined in screening mode. If you select "one eye", the screening will be done on the eye that the Keratograph 5M is currently facing.

Capture mode: Click to decide if the software should automatically go on to the next examination step (other eye or next examination) after completing a measurement/image.

Joystick time: Define the length of time that the joystick button must be held down to initiate video recording.

Adjusting the Camera: Camera groupbox

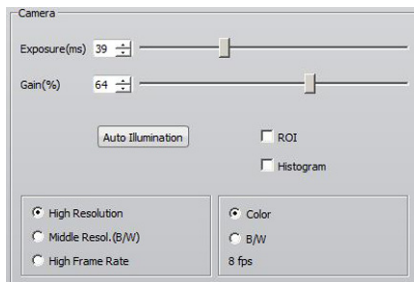

Exposure time: The longer the exposure time, the brighter the image will be. The image can, however, become less sharp as a result.

→ Change the exposure time using the slider control.

Gain: If you increase the gain value, the picture brightens. However, the image quality suffers as a result; too much gain results in grainy images.

→ Change the gain setting on the slider control.

Auto Illumination: You can adjust the illumination with this function, e.g. so as not to overexpose an image.

→ Press the button [Auto Illumination].

You can now adjust the illumination for the entire image capture.

High Resolution, Middle R. (B/W) or High Frame Rate: Details will be more visible at a higher resolution, high frame rates provide "smooth" videos.

Color or B/W: Choose colour or black and white display.

fps: frames per second

Buttons and Checkboxes

Start, stop or save your images or skip to the next examination step with the following buttons.



Abb. 10-36: Displayed buttons during an examination

[auto] checkbox: Changes the [Capture] button into [Capture+Next] button.

Capture + Next: Checkbox [auto] is enabled. If you click this button the image is captured. The software then skips to the next step in the worklist automatically.

Capture: [auto] checkbox is disabled. Capture an image or video.

REC/STOP: You start or stop the video recording with these buttons.

PREV: Click [PREV] to go back to the previous work step.

0/50: Progress bar of the worklist

NEXT: Click [NEXT] to go to the following work step.

Check quality of images

Show preview

If the checkbox is enabled after every captured image the user sees a little preview of the captured image. He can decide if he/she wants to keep or delete the image.

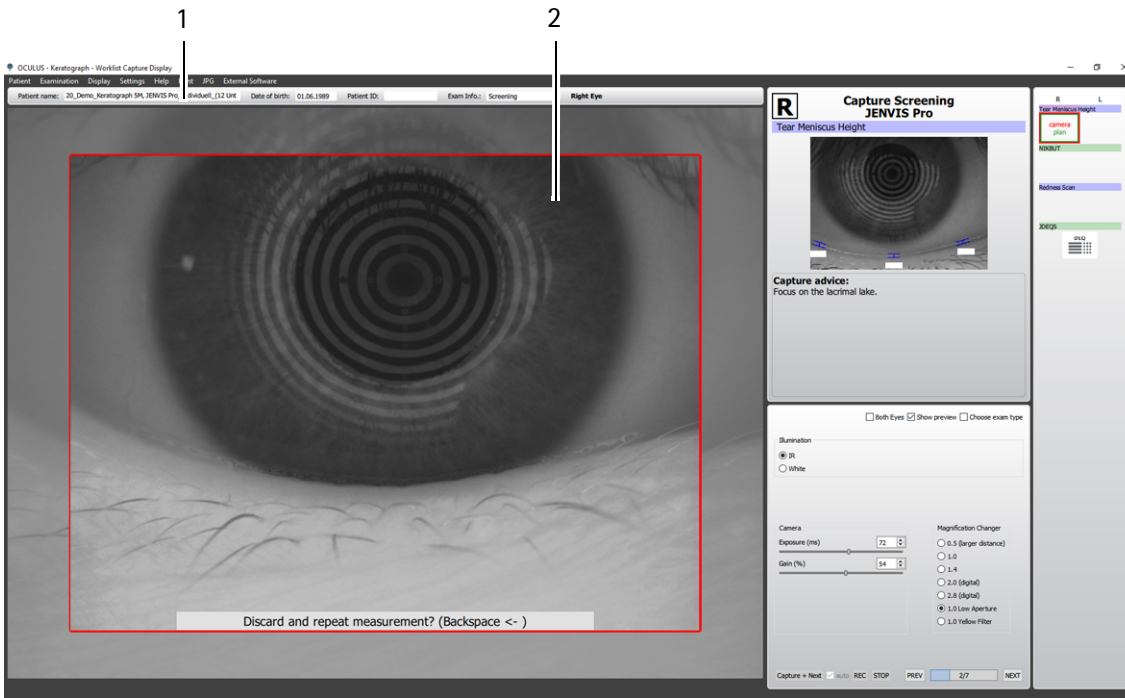

1 Patient/Exam Info

2 Preview

Abb. 10-37: Overview with preview

10.15.4 Printing a JENVIS Pro Dry Eye Report

Depending which type of the JENVIS Pro Dry Eye Report is used two layouts are available. You can print

- JENVIS Pro Dry Eye Screening
The Screening printout contains the results and description of the three screening tests.
- JENVIS Pro Dry Eye Report
The Report print out shows all assessed categories.

Using the Print button in the menu bar, the corresponding type can be send to a printer or printed as a PDF file. You can select between an entire print or a Recommendation Summary only.

➔ Select the [Print] menu item.

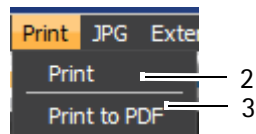

- 1 [Print] button
- 2 [Print to PDF] button

Fig. 10-38: [Print] menu item

Using the first entry you can physically print the JENVIS Pro Dry Eye Report (1).

The second entry enables to print the report as a PDF file (2).

The results of the dry eye examinations are shown on the printout of the JENVIS Pro Dry Eye Report. The JENVIS Pro Dry Eye Report includes a glossary of relevant terms for the patient.

11 Managing Patient Data

Once you have completed an examination, you can do the following with the patient data:

- Rename it, [sec. 11.1, page 73](#)
- Export it, [sec. 11.2, page 73](#)
- Import it, [sec. 11.3, page 74](#)
- Save it, [sec. 11.4, page 76](#)



For more information on Patient Data Management, refer to the [User Guide](#).

11.1 Rename Patient Data

After creating of the patient data, you can edit it.

- ➔ Press the [Change] button.
The input boxes for patient data are now enabled, and the cursor jumps to the "Last name" field.
- ➔ Change the entries in the individual boxes.
- ➔ Press the [Save] button.

11.2 Exporting Patient Data

Patient and examination data can be exported, for example, for forwarding to another clinic.

- ➔ Select the patient and also one of the examinations in the respective list as required.
- ➔ Press the [Export] button below the patient list. The following dialog will be displayed:

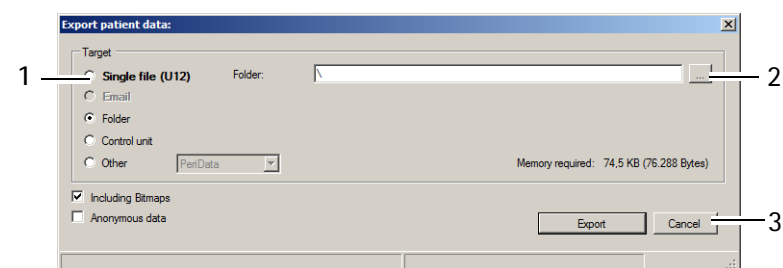

- 1 Saving destination selection
- 2 [...] button
- 3 [Cancel] and [Export] buttons

Fig. 11-1: "Export patient data" dialog



The default options for import and export of data are configured in the "Settings" field, see also the [User Guide](#).

Depending on the settings, you may not have to perform all of the following steps (e.g. selection of the directory).

- ➔ Select the "Target" (1) where you would like to export the data.



Recommendation: Export the patient data using the "Single file (U12)" option.

- ➔ Press the [...] button. (2).
- ➔ In the dialog that appears, select the folder or the file to which the patient data should be exported.
- ➔ Confirm your selection with [OK] or [Open].
- ➔ To export the data, press the [Export] button (3).

11.3 Importing Patient Data

If you receive patient data, for example, on a USB stick, you can import these data.



Note

Risk of loss of data due to computer viruses

Computer viruses can cause loss of data.

- ➔ Run a virus check before importing data from the USB flash drive.

➔ Press the [Import] button. The following dialog appears:

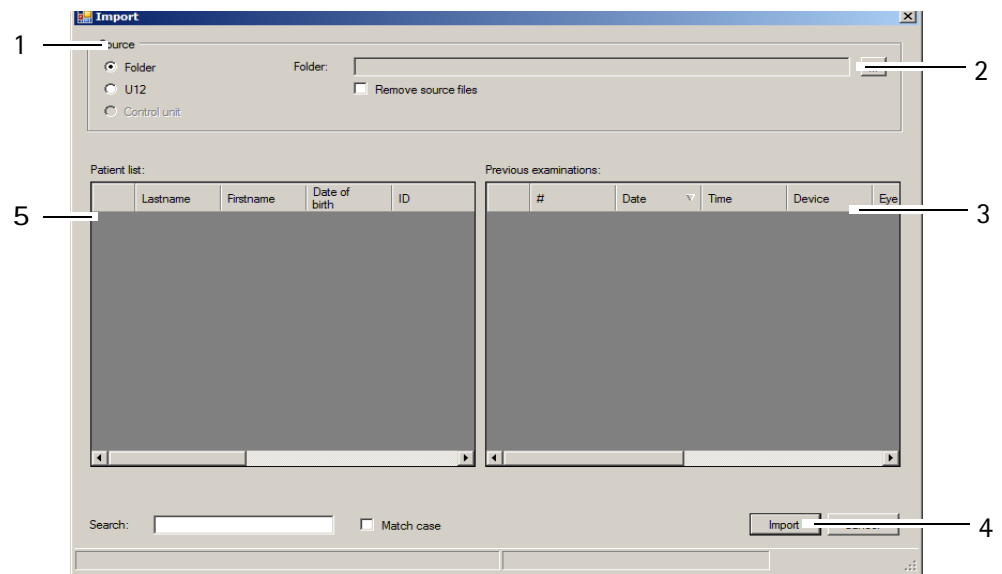

1 Select data source

2 [...] button

3 Previous examinations

4 [Import] button

5 Patient list

Fig. 11-2: "Import" dialog



The default options for import and export of data are configured in the "Settings" field, see also the [User Guide](#).

➔ Depending on the settings, you may not have to perform all of the following steps (e.g. selection of the directory).

➔ Select the option (1) where the source data are contained ("Folder" or "U12" (single file)).



Recommendation: Import the patient data using the "Single file (U12)" option.

➔ Press the [...] button. (2).

➔ In the dialog box, select the directory or the file where the patient data are located.

➔ Confirm your selection with [OK] or [Open].

The patients and the associated examinations that are found are displayed in the lower part of the dialog.

➔ To import the data, press the [Import] button (4).

The data will then be available in the Patient Data Management system.

11.4 Data Backup

You should make a backup copy of patient and examination data at regular intervals. In case of loss of data, you can reconstruct the data from a previously created backup with the help of this function. Since data backup takes several minutes, depending on the scope of the database and the data to be backed up, a backup should be carried out when the computer and the device are not in use.



Note

Risk of loss of data due to computer viruses
Computer viruses can cause loss of data.

➔ Run a virus check before making a backup to a USB flash drive.



The general rules for security backups apply to the creation of backup copies created with the help of the Patient Data Management system. Storage of backup files should always be done on a separate system (e.g. on a USB flash drive with adequate capacity).

11.4.1 Backup Data

➔ Press the [Backup] button at the top right of the Patient Data Management system. The following dialog appears:

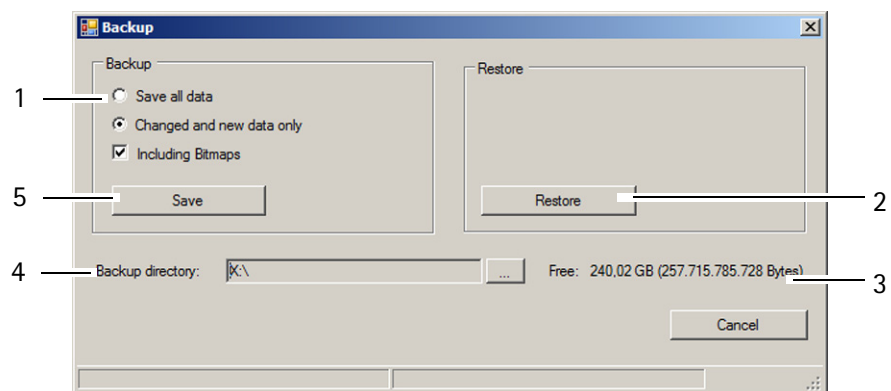

- | | |
|------------------------------|-------------------------------------|
| 1 Backup data selection | 4 Backup directory and button [...] |
| 2 [Restore] button | 5 [Save] button |
| 3 Display free storage space | |

Fig. 11-3: "Backup" dialog

➔ Select whether all of the data or only changed data should be backed up.



The Patient Data Management system internally tags all saved data records.

If you select the option "Changed and new data only", only the data records that were not saved will be backed up.

- Press the [...] button to the right of the "Backup directory" box (4).
- In the dialog that appears, select the folder to which the data should be backed up.
- Confirm your selection with [OK].
- To back up the data, press the [Save] button (5). The previously selected data will then be backed up to the corresponding folder.

11.4.2 Reconstructing Data

If a loss of data occurs, the data from a previous backup can be re-imported into the Patient Data Management system.

- Press the [...] button.
- In the dialog that appears, select the folder which contains the backup data.
- Confirm your selection with [OK].
- To import the data, press the [Restore] button (2). All data in the appropriate directory are copied to the Patient Data Management system.

11.4.3 Automatic Backup

In addition to the manually performed backup, it is also possible to automatically run a backup when exiting the Patient Data Management system. The settings required for this can be made in the "Settings" area, see [User Guide](#).

12 Reference Measurement

To achieve a high measuring accuracy, the Keratograph must be set up

- before conducting the first examination on a patient
- after changing the position of the Keratograph 5M

The first reference measurement is performed during setup by OCULUS or an authorized dealer. OCULUS recommends performing a reference measurement once each month.

The reference measurement can be performed easily and quickly using the reference sphere ($r = 8,000$ mm).

Required Materials

- Reference sphere ($r=8,000$ mm), provided
- Cleaning alcohol

Measuring With The Reference Sphere

Prerequisite: the Keratograph 5M must be turned on for at least 15 minutes.

For the reference measurement, proceed as follows:

- ➔ Thoroughly clean the reference sphere before saving reference values (e.g. with cleaning alcohol).
- ➔ Fasten the sphere holder to the chin-forehead rest.

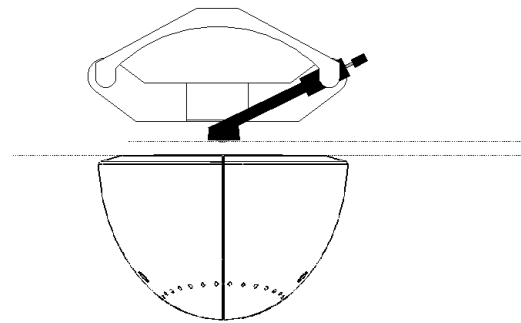

Fig. 12-1: Parallel alignment of the reference sphere

- ➔ Align the height based on the marks.
- ➔ In the [Settings] menu, select the [Reference Measure] menu item.
- ➔ Perform a measuring operation with the reference sphere ([sec. 10.4, page 30](#)).
- ➔ Confirm the question "Calibration done" with [OK].

The system is now ready for operation.

**Note**

If the error message "Reference sphere not completely measured!" appears, the sphere must be carefully cleaned and the measuring operation repeated.

The system is now ready for operation. The reference data is stored directly on the device, so that the measuring head is not dependent on a particular computer or laptop.

13 Maintenance, Cleaning and Repair

Cleaning of the Keratograph 5M is described in this chapter.

Sterilization is not required.

- ➔ Heed the product descriptions and instruction manuals of products and equipment you use to care for, clean, and disinfect the unit and/or its accessories.
- ➔ Do not clean the Keratograph 5M with aggressive, chlorine-containing, abrasive or sharp cleaning agents.



Note

Equipment damage due to penetration of moisture

- ➔ Make sure that no moisture can penetrate into the Keratograph 5M.



1 Placido bowl

2 Housing

3 Chinrest

4 Forehead rest

Abb. 13-1: Components for cleaning and disinfection

13.1 Cleaning



Attention

Risk of electric shock if the Keratograph 5M is not completely disconnected from the mains for these jobs.

- Turn the Keratograph 5M off, [sec. 8.2, page 19](#).
 - Pull the power plug before cleaning. When disconnecting electrical connections, pull on the respective plug and not on the cable itself.
-

Required materials:

- Cleaner with anti-static effect for plastic surfaces
- Cleaner for painted surfaces: Mixture of equal parts of alcohol and distilled water, possibly with a few drops of household detergent
- Soft, lint-free cloth

Cleaning intervals

- Clean the components of the Keratograph 5M once a month or if necessary.

Cleaning the Housing (2)

- It is best to clean the housing surfaces with a soft cloth and an anti-static cleaning agent.
- Wipe off any residue from painted surfaces with the mixture for painted surfaces.

Cleaning the Chin-Forehead Rest (3 and 4)

- Make sure that no liquid gets into any of the openings of the Keratograph 5M.
- Clean the chin-forehead rest with a soap solution (or with alcohol, if very dirty).
- Use a lint-free, damp cloth.

Cleaning the Placido Bowl (1)

The Placido bowl is a precision component and is pressure-sensitive. The surfaces of these components are susceptible to scratching.

- Take special care when cleaning the surface of the Placido bowl. Use a lint-free, dry cloth.
- Make sure that no dust gets into the little holes.
- If necessary, carefully clean the Placido bowl with a barely damp cloth.

13.2 Disinfection



Attention

Risk of electric shock if the Keratograph 5M is not completely disconnected from the mains for these jobs.

- Turn the Keratograph 5M off, [sec. 8.2, page 19](#).
 - Pull the power plug before cleaning. When disconnecting electrical connections, pull on the respective plug and not on the cable itself.
-

- Recommendation: Use disinfection wipes suitable for medical devices., for example:
 Mikrozyd sensitive wipes premium
 Fa. Schülke & Mayr
 Softpack 48 pieces
 Art.Nr. 165711
 Schülke & Mayr GmbH
 Telefon: +4940521000
 Telefax: +494052100318
 mail@schuelke.com
 www.schuelke.com
-



Note

Equipment damage caused by disinfectant solution

The disinfectant solution may damage the surface of the device if it is sprayed directly on it.

- Spray the disinfectant solution onto a cleaning cloth, do not spray it directly on the device.
-
- Turn the Keratograph 5M off, [sec. 8.2, page 19](#).
 - Disinfect the forehead rest after each examination, disinfect the housing if necessary.
 - If you do not use chin rest paper: Disinfect the chin rest after each examination.

13.3 Maintenance

The Keratograph 5M is designed so that no special maintenance is necessary. For safety reasons, we recommend that the illumination and electrical values be checked every two years.

- Please contact OCULUS Service for this.

13.4 Attaching Paper to the Chin Rest

If you want to attach new chin rest paper, follow these instructions:

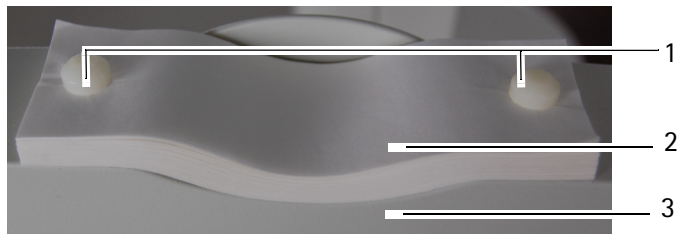

1 Pins

2 Paper for chin support

3 Chin rest

Fig. 13-2: Fasten chin rest paper

- ➔ Pull the two pins (1) out of the chin rest.
- ➔ Place the chin rest paper (2) in such a way that the holes of the paper and those in the chin rest (3) are aligned.
- ➔ Insert the two pins (1) in the chin rest.

14 Troubleshooting



Attention

Risk of personal injury or equipment damage due to improper troubleshooting

- ➔ If an error occurs which you are unable to correct by following the instructions below, label the device as "out-of-order" and contact our service department or an authorized dealer.

Error	Possible Cause	Remedy
After starting the Keratograph 5M program the dialog box opens: "No communication with the Keratograph 5M!".	No power to the power adapter.	Check whether the indicator light on the power adapter is on. If not, connect the power adapter to the mains.
	Connection cable (Y cable) Keratograph 5M/Power Adapter/ computer/Laptop are not plugged in properly.	Check whether <ul style="list-style-type: none"> ■ the connector is properly plugged into the Keratograph 5M ■ the USB connector is correctly plugged into the computer/laptop the connector for the low voltage side of the power adapter is plugged in
	Software/Hardware problems.	Switch off the Keratograph 5M and restart the computer. Switch on the Keratograph 5M as soon as the Patient Data Management becomes active. When you start the Keratograph 5M program, the message "Load Bootloader" must appear.

15 Transport and Storage

The Keratograph 5M, must be properly dismantled and packed before being transported or stored.

15.1 Transport and Storage Information

Storage

Ambient temperature range	-10 – +55°C
Relative humidity, including condensation	10 – 95%
Air pressure range	700 – 1060 hPa

Transport

Ambient temperature range	-40 – +70°C
Relative humidity, including condensation	10 – 100%
Air pressure range	500 – 1060 hPa

After transport and/or storage

- ➔ Wait approx. 3-4 hours after transport before putting the Keratograph 5M into initial operation. Extreme temperature changes from cold areas to warm rooms can cause condensation on the optical components.

15.2 Disassembly

- End the current session.



Fig. 15-1: Disassembly

- Disconnect the cable from the computer/laptop and the power adapter.
- Loosen the screw connection of the Y cable and pull it out. When disconnecting electrical connections, pull on the respective plug and not on the cable itself.

15.3 Transport and Storage



Attention

Risk of equipment damage due to incorrect shipment or from improper storage

- Avoid shocks, vibrations, and contamination.
 - Avoid high temperatures and humidity.
-
- Transport the Keratograph 5M carefully.
 - Do not hold the device by the joystick to carry it.
 - Store the Keratograph 5M in compliance with the storage conditions.
 - Avoid placing near heaters and moisture.

16 Disposal

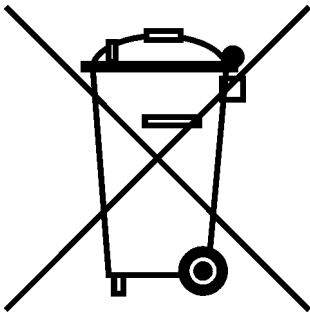

In accordance with Directive 2012/19/EC of the European Parliament and the Council and in accordance with German law governing the marketing, return and environmentally compatible disposal of used electrical and electronic devices, such appliances must be recycled and may not be discarded as household waste.

→ Dispose the Keratograph 5M in a compliant manner.

17 Terms of Warranty and Servicing

17.1 Terms of Warranty

Please note the following warranty provisions:

- Prior to and while operating the device it is important that you heed the instruction manual and safety instructions.
- In accordance with legal regulations, you are entitled to a warranty for the Keratograph 5M.
- If modifications are made to the Keratograph 5M by unauthorized persons, all warranty claims shall be voided. Improper modifications and repairs may result in considerable hazards to users and patients.
- Any entitlement to a warranty shall also be void if unauthorized persons interfere with the supplied computer hardware and software.
- Any transport damage must be reported immediately to the shipping company. Have the transport damage noted on the bill of lading so that complaint handling and compensation of damages can proceed in an orderly manner.
- In general, our Business and Shipping Terms on the date of purchase apply.

17.2 Assumption of Liability for Functions and Damage

OCULUS will only accept responsibility for the safety, reliability and serviceability of the Keratograph 5M if the unit is used in compliance with the following terms:

- Only use the equipment in conformance with this instruction manual.
- There are no parts either on or inside the Keratograph 5M that require maintenance or repair by the user. If assembly work, modifications, adjustments, repairs, changes or service are performed by unauthorized personnel, or if the Keratograph 5M is improperly maintained or handled, then any liability by OCULUS is voided.
- If the above-referenced work is performed by authorized persons, request a certification of the scope and type of repair, and, if necessary, the changes to the standard values or to the operating range from the service technician. This certification must contain the date of performance and statement of the performing firm, with signature.
- If requested, OCULUS will provide the service technician with a list of spare parts and additional descriptive material for this purpose.
- Make certain that only original OCULUS parts are used.

17.3 Manufacturer and Service Address

Supplemental information is available from our Service Department or from our authorized representatives.

Manufacturer and Service address:

OCULUS Optikgeräte GmbH
Münchholzhäuser Straße 29
35582 Wetzlar
GERMANY
Tel.: +49 641 2005-0
Fax: +49 641 2005-295
E-mail: export@oculus.de
www.oculus.de



USA:

OCULUS, Inc.
17721 59th Avenue NE
Arlington
WA 98223-1337
Tel. +1 425-670-9977
Fax +1 425-670-0742
e-mail: sales@oculususa.com
<http://www.oculususa.com>



18 Technical Data

Measuring Equipment

Measuring range	3 to 38 mm (0.1 to 1.5 in) 9 to 99 D
Accuracy	± 0.1 D
Reproducibility	± 0.1 D
Number of rings	22
Working distance	78 to 100 mm (3.1 - 3.9 in)
Number of analyzed data points	22000
Camera	digital CCD colour camera
Dimensions W x D x H	275 x 320 - 400 x 480 - 510 mm (10.8 x 12.6 - 15.7 x 18.9 - 20.2 in)
Weights	measuring equipment: 3.2 kg (7.1 lbs) with X-Y stage: 6.1 kg (13.5 lbs)
Interface	USB
Power supply	24 V DC; 2.1 A
Voltage	90 – 264 V AC
Max. power consumption	18 W
Life expectancy	10 years

LED illumination

Illumination	Colour	Wave length
Fluo	Blue	465 nm
Ring illumination	Infrared	810 nm
Meibo	Infrared	840 nm
Fixation	Red	660 nm
Anti-glare ring	White	-
Tear Film	White	-
Ring illumination	White	-

Power adapter

Power adapter HMEG49-S240210-7 (05150150)	
AC input	90 – 264 V AC
Frequency	47 – 63 Hz
DC output	24 V 2,1 A max. 50.5 W
Power consumption	131.1 VA
Fuses	Integrated overcurrent shut-off

Classification according to IEC 60601 - 1

Type of protection against electric shock	Protection class 2
Level of protection against electric shock	Type B
Level of protection against harmful penetration of water	IP20

Operating Conditions

Temperature	+10 – +35°C
Humidity	30 – 75%,
Air pressure	800 hPa – 1060 hPa

Storage conditions

Ambient temperature range	-10 – +55°C
Relative humidity, including condensation	10 – 95%
Air pressure range	700 – 1060 hPa

Transport conditions

Ambient temperature range	-40 – +70°C
Relative humidity, including condensation	10 – 95%
Air pressure range	500 – 1060 hPa

Computer

Use a computer which is in conformity with the DIN EN 62368-1 or DIN EN 60950 standard.

Recommended computer specifications	Intel® Core™ i5, 500 GB SSD, 8 GB RAM, Windows® 10, Intel® HD Graphics
The IT equipment (computer, monitor, etc.) must meet the requirements of IEC 62368-1 or IEC 60950	
Recommended screen size	24"
Recommended screen resolution	1920 x 1080 Pixel (Full HD)

CE in accordance with Regulation (EU) 2017/745 on Medical Devices



The unit is a class IIa product.

Conformity assessment procedure: (EU) 2017/745 MDR, Annex IX, Chapters I and III

19 Annex

19.1 Electromagnetic Compatibility

Medical electrical equipment is subject to special precautionary requirements with respect to EMC, and must be installed and operated according to the EMC-Instructions contained in the accompanying paperwork.

No special measures need be observed in respect of OCULUS devices and systems.

Portable and mobile RF-communications devices can interfere with electrically operated medical devices.

Environments for which the device is suitable:

- Professional healthcare facilities: Doctors' offices, clinics (not in MRI rooms or nearby HF surgical devices), optometrists, opticians or similar)

Produced in consideration of permissible deterioration during or caused by the EMC testing without affecting the essential performance criteria

- A short interruption of the USB connection during the examination is permissible because it will not affect the diagnosis, treatment and observation.

The essential performance of the Keratograph 5M besides basic safety is defined as:

- No essential performances present



Attention

The use of accessories, transducers and cables not specified by OCULUS (for example as replacement parts) may result in increased emissions or decreased immunity of the Keratograph 5M.

- ➔ Use only the original accessories, transducers and cables specified by OCULUS.

The use of accessories, transducers and cables specified by OCULUS with devices other than the Keratograph 5M may result in increased emissions or decreased immunity of the other device.

- ➔ Do not use the accessories, transducers and cables specified by OCULUS with devices other than the Keratograph 5M.

To be in compliance with the requirements of the IEC 60601-1-2. 6.1 and 6.2 the following types of equipment, accessories, power adapters and cables must be used.

Order number	Description	
77000	Keratograph 5M	
05200320	Cable with connector plug, EU standard	2.5 m (8.2021 feet)
05200210 (110 Volt)	Cable with connector plug, US standard	2.5 m (8.2021 feet)
05150150	Power adapter HMEG 49	24 V, 2.1A
70002	Med. secure Isolator + USB Connection acc.	2 m

19.2 Guidance and Manufacturer's Declaration - Electromagnetic Emissions and Immunity for the Keratograph 5M

Guidance and manufacturer's declaration electromagnetic emissions IEC 60601-1-2: 2015, based to table 1

The OCULUS Keratograph 5M is intended for operation in the electromagnetic environment specified below. The user of the Keratograph 5M should ensure that it is being used in such an environment.

Emissions test	Compliance	Electromagnetic environment – guidance
RF emissions CISPR 11	Group 1	The Keratograph 5M uses RF energy only for its internal function. Therefore, its RF emissions are very low and are not likely to cause any interference in nearby electronic equipment.
HF-emissions CISPR 11	Class B	
Harmonics emissions IEC 61000-3-2	Class A	
Voltage fluctuations / flicker emissions IEC 61000-3-3	complies	

Electromagnetic immunity, IEC 60601-1-2: 2015, based on table 4			
Immunity test	IEC 60601 test level	Compliance level	Electromagnetic environment - guidance
Electrostatic discharge (ESD) IEC 61000-4-2	± 8 kV contact ± 15 kV air	± 8 kV ± 15 kV	Floors should be made of wood or concrete or covered with ceramic tiles. If the floor is covered with synthetic material, the relative humidity must be at least 30%.
Power frequency (50/60Hz) magnetic field IEC 61000-4-8	30 A/m 50 Hz or 60 Hz	30 A/m 50 Hz or 60 Hz	Power frequency magnetic fields should be at levels characteristic of a typical location in a typical commercial or hospital environment.
Electromagnetic immunity, IEC 60601-1-2: 2015, based on table 5, 8			
Electrical Fast transient/bursts IEC 61000-4-4	± 2 kV for power supply lines 100 kHz repetition frequency ± 1 kV for input/output lines	± 2 kV ----- ± 1 kV	Mains power quality should be that of a typical commercial or hospital environment.
Surge IEC 6100-4-5	± 1 kV line(s) to line(s) ± 2 kV line(s) to earth	± 1 kV differential mode ± 2 kV line(s) to earth	Mains power quality should be that of a typical commercial or hospital environment.
Voltage dips, short interruptions, and voltage variations on power supply input lines IEC 61000-4-11	0% U_T ; 1/2 period at 0, 45, 90, 135, 180, 225, 270 and 315 degree 0% U_T ; 1 period and 70% U_T ; 25/30 periods Single-phase: at 0 degree 0% U_T ; 250/300 periods	0% U_T ; 1/2 period at 0, 45, 90, 135, 180, 225, 270 and 315 degree 0% U_T ; 1 period and 70% U_T ; 25/30 periods Single-phase: at 0 degree 0% U_T ; 250/300 periods	Mains power quality should be that of a typical commercial or hospital environment. If the user of the Keratograph 5M requires continued operation during power mains interruptions, it is recommended that the Keratograph 5M be powered from an uninterruptible power supply or battery.
Note: U_T is the a.c. mains voltage prior to application of the test level.			

Electromagnetic immunity, IEC 60601-1-2: 2015, based on table 4, 5			
Immunity test	IEC 60601 test level	Compliance level	Electromagnetic environment - Guidelines
<p>Conducted RF IEC 61000-4-6</p>	<p>3 V_{eff} 150 KHz to 80 Mhz</p> <p>6 V in ISM- and amateur radio frequency bands between 150 kHz and 80 MHz</p> <p>80% AM to 1 kHz</p>	V _{eff} = 3 V	<p>Portable and mobile RF communications equipment should be used no closer to any part of Keratograph 5M, including cables, than the recommended separation distance calculated from the equation applicable to the frequency of the transmitter.</p> <p>Recommended separation distance</p> $d = \left[\frac{3,5}{(V_1)} \right] \sqrt{P}$ $d = \left[\frac{3,5}{(E_1)} \right] \sqrt{P} \quad 80\text{MHz to } 800 \text{ MHz}$ $d = \left[\frac{7}{(E_1)} \right] \sqrt{P} \quad 800 \text{ MHz to } 2.5 \text{ GHz}$ <p>where P is the maximum output power rating of the transmitter in watts (W) according to the transmitter manufacturer and d is the recommended separation distance in metres (m).</p> <p>Field strength from fixed RF transmitters, as determined by an electromagnetic site survey (a), should be less than the compliance level in each frequency range (b).</p> <p>Interface may occur in the vicinity of equipment marked with the following symbol:</p> 
<p>Radiated RF IEC 61000-4-3</p>	<p>3 V/m 80 MHz to 2,7 GHz</p> <p>80% AM at 1 kHz</p>		
<p>Note 1:</p>	At 80 Hz and 800 MHz, the higher frequency range applies.		
<p>Note 2:</p>	These guidelines may not apply in all situations. Electromagnetic propagation is affected by absorption and reflection from structures, objects and people.		
<p>a. Field strengths from fixed transmitters, such as base stations for radio (cellular/cordless) telephones and land mobile radios, amateur radios, AM and FM radio broadcast, and TV broadcast cannot be predicted theoretically with accuracy. To assess the electromagnetic environment due to fixed RF transmitters, and electromagnetic site survey should be considered. If the measured field strength in the location in which the Keratograph 5M is used exceeds the applicable RF compliance level above, the Keratograph 5M should be observed to verify normal operation. If abnormal performance is observed, additional measures may be necessary, such as re-orienting or relocating the Keratograph 5M.</p> <p>b. Over the frequency range 150 KHz to 80 MHz, field strengths should be less than 3 V/m.</p>			

Recommended separation distances between portable and mobile RF communications equipment and the Keratograph 5M

The Keratograph 5M is intended for use in an electromagnetic environment in which radiated RF disturbances are controlled. The customer or the user of the Keratograph 5M can help prevent electromagnetic interference by maintaining a minimum distance between portable and mobile RF communications equipment (transmitters) and the Keratograph 5M as recommended below, according to the maximum output power of the communications equipment.

Rated maximum output power of transmitter W	Separation distance according to frequency of transmitter m		
	150 KHz to 80 Mhz $d= 1.2 \sqrt{P}$	80 MHz to 800 MHz $d= 1.2 \sqrt{P}$	800 MHz to 2.5 GHz $d= 2.3 \sqrt{P}$
0.01	0.12	0.12	0.23
0.1	0.38	0.38	0.73
1	1.2	1.2	2.3
10	3.80	3.80	7.3
100	12	12	23

For transmitters rated at a maximum output power not listed above, the recommended separation distance d in metres (m) can be estimated using the equation applicable to the frequency of the transmitter, where P is the maximum output power rating of the transmitter in watts (W) according to the transmitter manufacturer.

NOTE 1: At 80 MHz and 800 MHz, the separation distance for the higher frequency range applies.

NOTE 2: These guidelines may not apply in all situations. Electromagnetic propagation is affected by absorption and reflection from structures, objects and people.

19.3 Description of the Connection

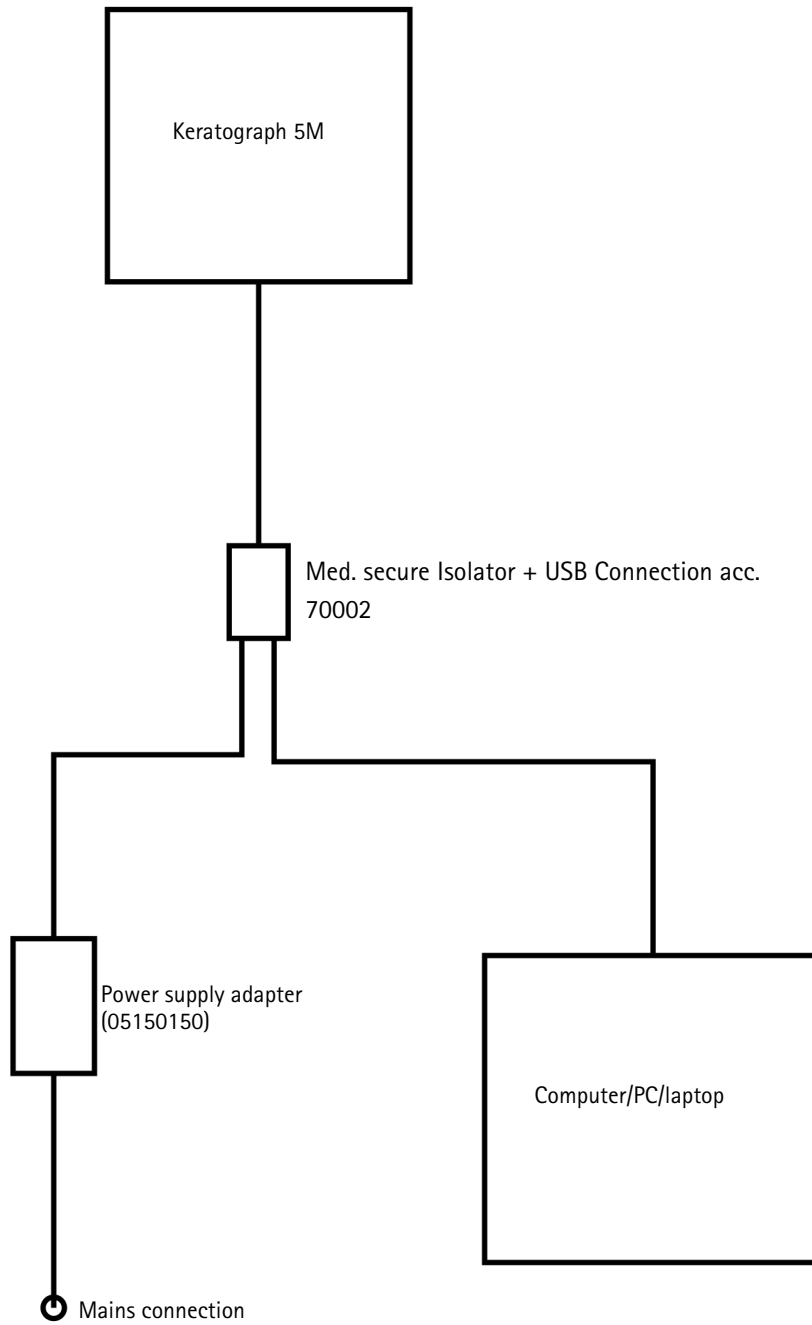

19.4 Data Sheet HEMG 49-S240210-7 [05150150]

HiTRON

UNIVERSAL INPUT AC-DC MEDICAL & ITE APPLICATION EXTERNAL DESKTOP SWITCHING ADAPTER 48-50 WATTS GREEN POWER SINGLE OUTPUT HEMG49 SERIES



FEATURES:

- ACCOMMODATE UNIVERSAL AC INPUT
- MEET MEDICAL STANDARDS IEC60601-1 & ITE STANDARDS IEC60950-1
- EMI MEET EN 55011 & EN55022 / FCC CLASS B
- MEET ENERGY STAR LEVEL V & CEC LEVEL IV
- CE MARKING COMPLIANCE

SPECIFICATION

INPUT SPECIFICATION

Input Voltage: Typical 90-264Vac.
Input Connector: 3 pole AC inlet IEC320-C14(DT7) / 2 pole AC inlet IEC320-C8(DT8).
Input Frequency: 47-63Hz.
Inrush Current: 12Arms (52Apk) at 230Vac.
Input Current: Typical 0.91A at 115Vac/ 0.57A at 230Vac.
Dielectric Withstand: Meet IEC60601-1 & IEC60950-1.
EMI: Meet EN55011 & EN55022 / FCC Class B.
Hold-up Time: Typical 12mS at 115Vac. Typical 70mS at 230Vac.
Over Temp. Protection: Optional (NTC circuit).
Earth Leakage Current (Class I) : Less than 0.3 mA.
Touch Leakage Current (Class I & II) : Less than 0.1mA.
No Load Power: Less than 0.3W at 230Vac

OUTPUT SPECIFICATION

Output Voltage: See Ratings Chart.
Output Current: See Ratings Chart.
Output Wattage: Typical 48-50Watts.
Output Connector & Cord: Optional.
Line Regulation: Typical 0.1%.
Load Regulation: Typical $\pm 1.5-3.0\%$.
Noise & Ripple: 1.0% peak to peak.
OVP: Built-in by latch circuit.
Adjustability: Factory set.
Over Current Protection (OCP):
 Fully protected against output overload and short circuit. The PSU will shut down after OCP is activated. Consult the factory for OCP setting.

GENERAL SPECIFICATION

Efficiency: Typical 87%-88% (various with the output voltage)
Switching Frequency: Typical 65KHz.
Circuit Topology: Fixed Frequency Flyback circuit.
Transient Response: Output voltage returns in less than 5.5mS following a 50% load change.
Safety Standard: Meet Medical IEC60601-1 & ITE IEC60950-1, Class I for DT7(C14) or Class II for DT8(C8)
Operating Temperature: 0°C to +40°C.
Storage Temperature: -20 to +85°C.
Cooling: Free air convection.
Construction: Impact resistant thermo-plastic enclosure case.
Power Density: 3.14-3.27Watts. / Cubic inch.
Desktop Format.

NOTE: (1) All measurements are at nominal input, full load, and +25°C unless otherwise specified.
 (2) Load regulation is measured at 115Vac or 230Vac in percentage to indicate the change in output voltage as the load varied from half load to full load ($\pm\%$).
 (3) The exact obtainable load regulation depends upon the output cord selected and load current.
 (4) Due to requests in market and advances in technology, specifications subject to change without notice.



For the details of safety approval, please consult the factory.

OUTPUT VOLTAGE / CURRENT RATINGS CHART

SINGLE OUTPUT

MODEL NO.	AC INLET	O/P VOLTAGE	O/P CURRENT
HEMG49-S120400-7	IEC320-C14(DT7)	12.0Vdc	4.0A
HEMG49-S120400-8	IEC320-C8(DT8)	12.0Vdc	4.0A
HEMG49-S150330-7	IEC320-C14(DT7)	15.0Vdc	3.3A
HEMG49-S150330-8	IEC320-C8(DT8)	15.0Vdc	3.3A
HEMG49-S240210-7	IEC320-C14(DT7)	24.0Vdc	2.1A
HEMG49-S240210-8	IEC320-C8(DT8)	24.0Vdc	2.1A

MECHANICAL DIMENSIONS: MM [INCHES]

WEIGHT: 373.0g (13.2 Oz.)

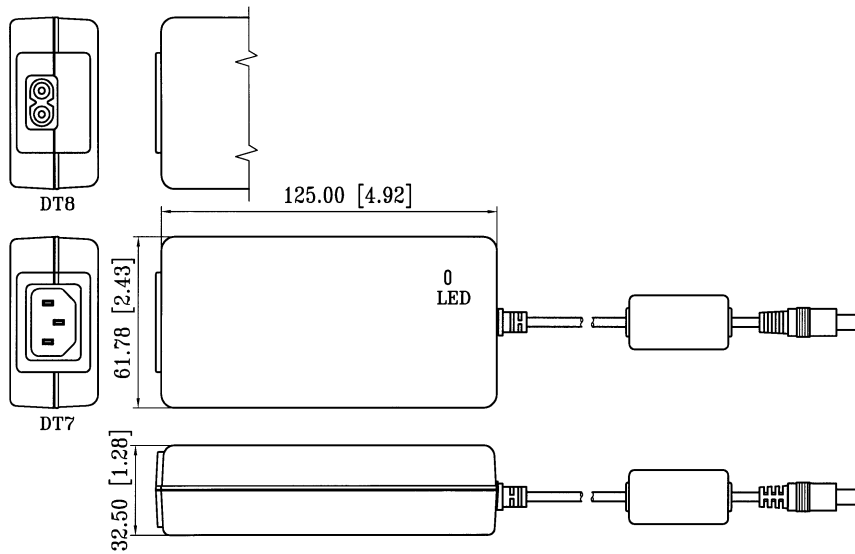

19.5 Instructions for integration into an IT-Network

The device, in conjunction with the connected computer and the device software running on it, forms a programmable electrical medical system (PEMS) according to IEC 60601-1.

It is essential that you follow the cybersecurity instructions section of "Safety Instructions" in the device instruction manual.

Please note the following information for implementing an integration of the PEMS into an IT-Network:

The purpose of integrating the PEMS into an IT-Network can be:

- Licensing by local license server
- Storage and retrieval of the examination data on a local network drive
- Printing
- Data export
- DICOM workflow

Required characteristics of the IT-Network into which the PEMS is to be integrated:

- Prefer wired LAN connection
- IPv4 network
- Fast-Ethernet (100 Mbit/s minimum)

Required configuration of the IT-Network into which the PEMS is to be integrated:

- Licensing: required opened ports: 3968 TCP; 51371 - 51372 UDP
- Storage, printing, data export: File and Printer Sharing for Microsoft Networks (SMB 3.0 or higher - required opened port: 445]
- DICOM Storage Service Class = PACS
- DICOM Worklist Management Service Class (Modality Worklist Server)

Technical specifications of the network connection with the PEMS, including the specifications of data security:

- Refer to the cybersecurity section of "Safety Instructions" in the device instruction manual.
- Refer to the "Floating License Key - License management for software options" instruction manual (if applicable)
- Refer to device specific DICOM interface description (if applicable)

The intended flow of information between PEMS, the IT-Network and other devices in the IT-Network and the intended routing through the IT-Network

- License handling from local license server to PEMS and vice versa
- Storage and data export to local network storage and loading from local network storage
- Printout to local printer

List of hazard situations that result from the IT-Network being unable to provide the features that are required to fulfill the purpose of integrating the PEMS into to meet the IT-Network:

- Loss of data
- unsuitable data exchange
- Data corruption
- unsuitable temporal data allocation
- unexpected data reception
- unauthorized access to data



Connection of the PEMS to an IT-Network that includes other equipment could result in previously unidentified risks to patients, operators or third parties.

The responsible organization should identify, analyze, evaluate and control these risks.

Subsequent changes to the IT-Network could introduce new risks and require additional analysis.

Changes to the IT-Network include:

- changes in IT-Network configuration
 - connection of additional items to the IT-Network
 - disconnecting items from the IT-Network
 - update of equipment connected to the IT-Network
-

Manufacturer and Service Address

Headquarters:

OCULUS Optikgeräte GmbH

Münchholzhäuser Straße 29 • 35582 Wetzlar • GERMANY

Tel. +49 641 2005-0 • Fax +49 641 2005-295

E-Mail: export@oculus.de • www.oculus.de

G/77000/XXXX/EN
Lot:

