

OCULUS Pentacam® AXL



INSTRUCTION MANUAL

System for measuring the anterior eye
segment and optical biometry

Notes on this instruction manual

The Pentacam® AXL has been manufactured and tested according to strict quality criteria.

To ensure safe operation, it is essential that you use the device correctly. For this reason you should familiarise yourself thoroughly with the contents of this instruction manual before operating the device. In particular, pay attention to the safety instructions.

- This instruction manual describes how to manage patient data, the default settings of the Pentacam® AXL program and the measuring process.
- The Pentacam® AXL reference manual contains information supplementing the description of the operating concept.

Due to ongoing development, the diagrams shown may depict minor changes to the actual device delivered.

If you have any queries or would like additional information about your device, do not hesitate to call or send us an email or a fax. Our service team will gladly assist.

OCULUS Optikgeräte GmbH

Revision 04

Release: 05.11.2021



OCULUS is certified according to DIN EN ISO 13485, setting high standards of quality where development, manufacture, quality assurance and service regarding the entire range of products are concerned.

Table of Contents

1	Delivery and Deliverables	1
2	Symbols	3
3	Structure of the Documentation.....	4
4	Safety Instructions.....	5
4.1	About this Manual.....	5
4.1.1	Pictogram Used in this Manual.....	5
4.2	Safety Instructions for Use	6
4.3	Cybersecurity Instructions.....	11
5	Intended Use.....	14
6	Device Description.....	16
6.1	Overview of the device components	16
6.2	How the Pentacam® AXL works.....	17
7	Setup and Connection.....	18
7.1	Electrical Connection.....	19
7.2	Switching On.....	20
7.3	Switching Off.....	20
7.4	Software Installation on separate PCs.....	21
8	Patient Data Management	22
8.1	Starting Patient Data Management.....	22
8.1.1	Entering a New Patient	22
8.1.2	Selecting an Existing Patient.....	23
8.2	Starting the Pentacam® AXL Software.....	24
9	Pentacam® AXL Program.....	25
10	Scan Menu.....	27
10.1	Screen layout	27
10.1.1	Scheimpflug image settings.....	28
10.2	Information for recording Scheimpflug images.....	30
11	Measuring Procedure.....	31
11.1	Measuring Procedure to Measure the Axial Length	31
11.2	Measuring Procedure for the Anterior Segment of the Eye	39
11.3	Quality Specifications.....	45
11.3.1	Quality Specifications in the Pentacam® AXL program.....	45
11.3.2	Quality Specifications in the Pentacam® program.....	49
12	Managing Patient Data.....	52
12.1	Rename Patient Data.....	52
12.2	Exporting Patient Data.....	52
12.3	Importing Patient Data	54
12.4	Data Backup	55
12.4.1	Backup Data.....	56
12.4.2	Reconstructing Data.....	56

12.4.3	Automatic Backup.....	57
13	Test measurement with the Pentacam® AXL.....	57
13.1	Test measurement: Tomography (3D scan)	57
13.2	Test measurement: Axial length.....	57
13.2.1	Attach the test eye.....	57
13.2.2	Carrying out the test measurement.....	59
14	Cleaning, Disinfection and Maintenance.....	62
14.1	Cleaning.....	62
14.2	Disinfection.....	64
14.3	Maintenance	65
14.4	Attaching Paper to the Chin Rest	66
15	Troubleshooting	67
16	Transport and Storage.....	68
16.1	Information on Transport and Storage	68
16.2	Disassembly	69
16.3	Transport and Storage	69
17	Disposal	70
18	Terms of Warranty and Servicing	70
18.1	Terms of Warranty.....	70
18.2	Assumption of Liability for Functions and Damage.....	71
18.3	Manufacturer and Service Address.....	71
19	Technical Data.....	72
20	Annex.....	75
20.1	Electromagnetic Compatibility	75
20.2	Guidance and Manufacturer's Declaration - Electromagnetic Emissions for the Pentacam® AXL.....	76
20.3	Description of the Connection	80
20.4	Data Sheet HEMG 49-S240210-7 (05150150).....	81
20.5	Instructions for integration into an IT-Network.....	83

1 Delivery and Deliverables

Product and accessories	Order number
Pentacam® AXL	70100
Pentacam® AXL® accessories	70701
■ x-y base	-
■ Power supply	05150150
■ Dark sheet	027070000006
■ Washing manual	027070000007
■ Wire clip	027075000004
■ Hexagon screwdriver	05520010
■ Test eye	70108
■ External hard drive	05460335
Additional Export package with head- and chinrest	70734
■ Support plate	017051501012
■ Cograil	027051701004
■ Cover	027051701005
■ Sliding plate	017051701006
■ Chinrest paper	65313
■ Head and chin rest	70518
■ Instruction Manual	G/70100/EN 1121 Rev04
■ User Guide	UG/70700/xxxx/ EN
■ Software Installation	SI/50000/xxxx/EN
Additional accessories:	
■ Dustcover	026010005001
■ Y cable with galvanic isolation 2 m	70002
■ Extension cable for Y cable 4 m	10002173
■ Electric cable EU	05200320
■ Electric cable US	05200210
■ Electric cable GB	05200211
■ Electric cable Australia	05200212

Software module	Order number
Standard software package Pentacam® AXL:	
■ Floating License Key with manual	77900 SI/77900/.../de
■ Viewing License Pentacam® AXL	70725
■ Fast Screening Report	70927
■ IOL Calculator	70110
■ Belin/Ambrósio Enhanced Ectasia Display	70728
■ Contact Lens Fitting incl. Fourier Analysis	70726
■ Holladay Report & Holladay EKR65 Detail Report	70729
■ Software Package Cataract Cataract Software PNS and 3D Cataract Analysis Zernike Analysis	70820
■ Software Package Refractive Refractive Software Corneal Optical Densitometry	70810
■ Pentacam® AXL Data-USB-Stick	017090901001
Optional software module	Order number
3D pIOL Simulation Software and Aging Prediction	70928
Module DICOM PACS	70718

We reserve the right to change the scope of delivery in line with ongoing technical development.

- ➔ If you find transport damage upon delivery, immediately file a claim with the transport company.
- ➔ Have the damages noted on the bill of lading, so that your claim for damages can be handled properly.

For more information regarding shipping and handling, see [sec. 16, page 68](#).



- The software version of the patient data management appears in the settings of the patient data management software.
- The software version of the Pentacam® AXL program appears in the Pentacam® AXL settings.
- The minimum screen resolution of the Pentacam® displays is 1280x720 with a text size of 100%.

2 Symbols

Symbols on the device		Symbols, packaging			
	Manufacturer		Protection class		Keep dry
	Date of manufacture	IP XX	Type of protection		This way up
	Conformité européenne		Article number		Fragile
	Follow instruction for use		Serial number		Transport Limit of temperature for transport
	Disposal in household trash is prohibited		Medical device		Storage Limit of temperature for storage
	Applied part Type B		Attention		Limit of humidity
(21) ABCDEFG123456789 (01) 04049584000040	Example: UDI number, consisting UDI-DI (Device-Identification) UDI-PI (Product Identifier) machine-readable matrix code				Limit of air pressure

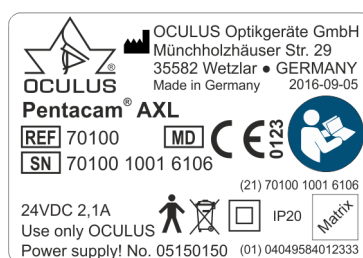

Fig. 2-1: Name plate (example)

3 Structure of the Documentation

A folder containing documentation is supplied with your Pentacam® AXL:

- **Instruction Manual:** The design of the unit is described in detail in this document. The instruction manual also gives you general information about working with the Patient Data Management system and all safety-related instructions for use of the Pentacam® AXL.



Attention

All safety-related instructions for use of the Pentacam® AXL are given in the Instruction Manual for the unit. It is imperative that you read and understand the whole Instruction Manual before you use the Pentacam® AXL.

-
- **User Guide:** All features of the examination and analysis software are described in the User Guide, along with detailed information about the Patient Data Management system.
 - **Software Installation:** The introduction to the Software Installation describes how to install the Pentacam® AXL software and the associated drivers.
 - **Manual Floating License Key:** information on the use of the Pentacam® AXL within networks.

4 Safety Instructions

4.1 About this Manual

- ➔ Carefully read through the Instruction Manual.
- ➔ Keep the Instruction Manual in good condition near the device.
- ➔ Observe the legal regulations with regard to accident prevention.

4.1.1 Pictogram Used in this Manual



Attention

Identifies a potentially dangerous situation which may cause minor injury or damage to property.



Note

Denotes situations which could result in incorrect findings, denotes user instructions and useful or other important information.



Identifies important information about the product and its use which require special attention.

- > This symbol denotes menu paths and screen shots. Example for starting a new examination:

Pentacam® AXL > Examination > Scan

which means:

- ➔ Select the "Examination" menu from the menu bar.
- ➔ Select the menu item "Scan".

4.2 Safety Instructions for Use



Attention

Personal injury or property damage due to improper operation

→ Observe the following safety instructions.

Personal injury or property damage due to equipment modifications that could jeopardize safety

- No modifications may be made to this device without the permission of the manufacturer. Only the OCULUS service and authorized dealers are allowed
- to modify the device or the associated lifting table
 - to install software and software updates.
-

Any serious-incident that has occurred in relation to the device should be reported to the manufacturer (vigilance@oculus.de) and the competent authority of the region in which the user and/or patient is established.

Instructions for Operating Personnel

→ Make certain that the Pentacam® AXL is used exclusively in clinics and by eye specialists and opticians (trained staff etc.). It must be used in the area designated for carrying out examinations.

For this reason the device may only be operated by personnel instructed to do so, who, with appropriate training, knowledge and practical experience, are able to ensure proper handling of the device.

Transport and Storage Instructions

Refer to the notes in *sec. 16, page 68*.

Instructions for Setup and Connection

- Only OCULUS or an authorized dealer is allowed to set up and to connect the Pentacam® AXL.
- Do not use or store the Pentacam® AXL in rooms that are humid, see *sec. 16, page 68*.
- Keep the Pentacam® AXL away from water that may drip, splash or spray on it, and make sure that no liquids can get into the Pentacam® AXL. Do not place any containers holding liquids in the vicinity of the Pentacam® AXL.
- Germany: Only operate the Pentacam® AXL in rooms used for medical purposes after they have been set up according to the VDE Regulation 0100-710.

- Do not operate the devices included in the delivery in areas where explosions may occur, or in proximity to flammable anesthetics or volatile substances such as alcohol, benzine or similar products.
- Set up the Pentacam[®] AXL so that the power plug is easy to access. That way, you can easily disconnect it from the power supply for any repairs or maintenance work.
- Do not force any plug connections.
If you are unable to make a plug connection, check whether the plug fits the socket.
If you detect damage to the connection, you should let authorized dealer repair the damage.
- Only use a device which is mounted at the lifting table properly.

Patient environment information

Patient environment is the area where patients can come into contact with any part of a medical electrical equipment (ME equipment) or with another person being in contact with the ME equipment.



Attention

In the patient environment, use devices that conform to IEC 60601-1. If a multiple power socket is to be used, or if a device is to be used that does not meet the IEC 60601-1 standard, use an isolating transformer.

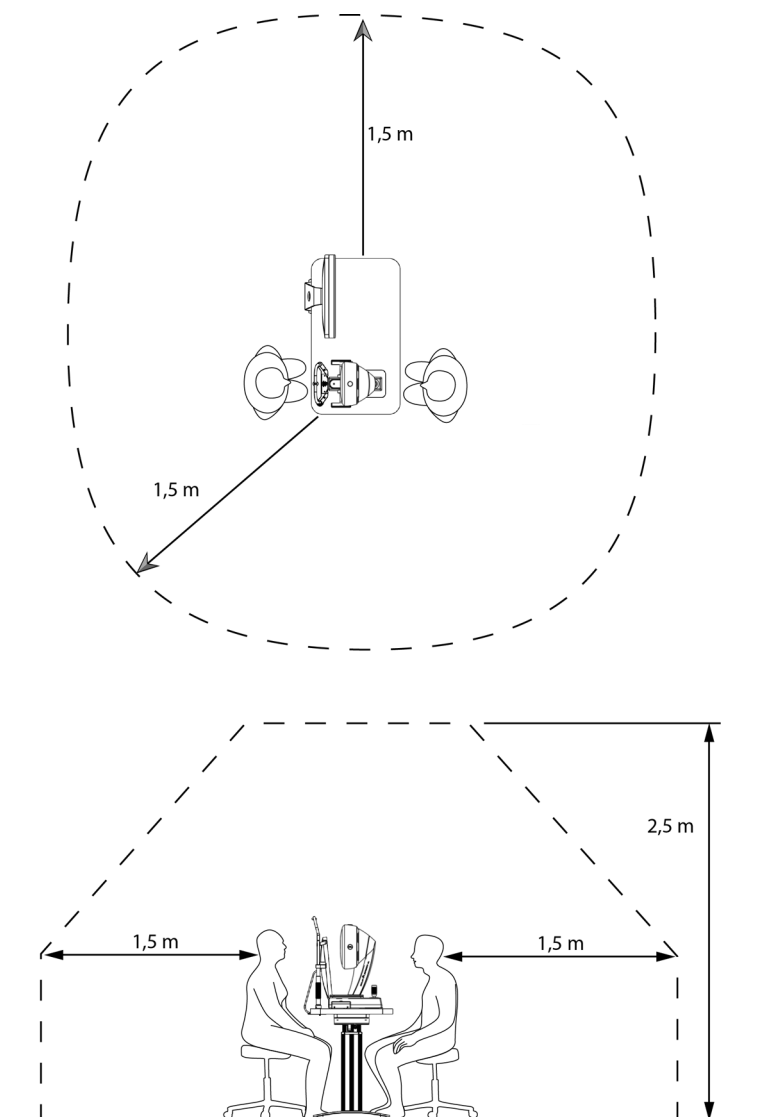

Fig. 4-1: Patient environment

Information about the operation of an ME system

The Pentacam® AXL and a connected computer form a medical electrical system (ME system) according to IEC 60601-1. If you connect

additional devices, such as, for example a printer, those devices become part of the ME system.

- Make sure that all devices of the ME system meet the requirements of IEC 60601-1 or IEC 60950-1/IEC 62368-1.

Instructions for Operation

- Before first use: Let OCULUS or an authorized dealer train you in the operation of the Pentacam® AXL.
- Never operate a damaged Pentacam® AXL.
- Only operate the Pentacam® AXL with the original accessories supplied by us and only when the unit is in technically perfect condition.
- Do not cover the ventilation openings.
- Do not touch the patient and the device at the same time.
- Make sure that the device cannot tip over by leaning against it or sitting on it.
- Do not put the Pentacam® AXL, including rechargeable battery or cable, down onto devices that produce heat, heaters (for example radiators), microwaves or similar.
- Only operate the device if you have understood the operating instructions.



Caution

The light emitted from this instrument is potentially hazardous. The longer the duration of exposure and the greater the number of pulses, the greater the risk of ocular damage. Exposure to light from this instrument when operated at maximum output will exceed the safety guideline after 48 treatments.



Instructions for Laser Use

Attention

Risk of personal injury or material damage due to invisible laser radiation. The Pentacam® AXL contains a Class 1 laser according to IEC 60825-1: 2014. It is an encapsulated laser system. When the Pentacam® AXL cover is opened, you may be exposed to invisible, Class 3R (5 mW) laser radiation.

- Never open the unit.
 - For authorized service personnel only: When doing maintenance jobs, avoid looking directly into the laser beam.
-

Instructions for Maintenance

In order to retain the high measurement accuracy of the Pentacam® AXL OCULUS Optikgeräte GmbH recommends to perform a maintenance service every two years or after 25000 scans. A corresponding message appears, see [sec. 14.3, page 65](#). Additionally to that it is usefull to accomplish a test measurement of the axial length measuring mode everyday before you start working with the Pentacam® AXL.

If an error occurs which you cannot correct, label the Pentacam® AXL as being "out-of-order" and contact our service department, see [sec. 18, page 70](#).

Instructions for Disassembly and Disposal

- ➔ When disconnecting electrical connections, pull on the respective plug and not on the cable itself.
- ➔ Dispose of the device according to legal regulations.

Instructions on Electrical Safety



Attention

Risk of personal injury or damage to property due to an incorrect level of safety

Connecting the Pentacam® AXL with its non-medical electrical equipment (e.g. data processing equipment) to a medical electrical system must not result in a patient safety level below that prescribed by IEC 60601-1. If making this connection leads to the leakage current threshold being exceeded, protective measures including a circuit breaker must be in place.

- ➔ Ensure that connections with non-medical devices are made correctly.
- ➔ Only use the power adapter listed in the packing list.
- ➔ Use only a computer that meets the specifications given in this instruction manual, [sec. 19, page 72](#).

Use of a multiple socket extension cord

Risk of personal injury or material damage caused by unsafe multiple socket extension cord

If you use a multiple socket extension cord to connect the Pentacam® AXL to the power supply, you must heed the following information:

- ➔ Use an extension cord that complies with the requirements of IEC 60601-1, section 16.
- ➔ Do not place the multiple socket extension cord on the floor.
- ➔ Do not use more than one multiple socket extension cord.

- ➔ Plug only the Pentacam® AXL and the computer that is being used with the unit (if applicable) into the multiple socket extension cord.

If you are using a multiple socket extension chord it has to be supplied with a isolation transformer.

If you are using a new computer for the Pentacam® AXL, you must have the electrical safety checked. Call OCULUS Service for this purpose.



Attention

Electromagnetic Compatibility (EMC) / Cables

Risk of personal injury or damage to property due to electromagnetic interference

Portable and mobile RF communications equipment can affect medical electrical equipment *sec. 20, page 75*.

- ➔ Make sure that portable and mobile RF communications equipment do not cause interference.
- ➔ Recommendation: Maintain a minimum distance of 4 m. If the distance is shorter, you must ensure that the Pentacam® AXL functions correctly.

4.3 Cybersecurity Instructions



The device itself was not designed to connect via a coupled computer to the internet or other network, or to portable media, as the device does not require a network or internet connection to function.

User who elect to connect the device coupled computer to the internet or other network for other purposes are responsible for ensuring that it is done so in a controlled manner.

Data responsibility:

The device itself is not designed to connect with the internet, but only with a computer. It does not require the internet to function.

Do not connect with the internet while using the device. It is considered misuse.

If you elect to connect the computer to the internet for other purposes you are responsible for ensuring data security.

Device Security

It is the responsibility of the authorized user to ensure that the Pentacam® AXL device is not left unlocked, or otherwise unsecured when not in use, to ensure that non-authorized medical, professional, or

otherwise unapproved personnel are not exposed to, or gain access to, ePHI.

User Responsibility

User names or passwords must not be shared with colleagues or others, even if they are permitted by law and provider policy to view the same type of information (e.g. two operators reviewing the same patient samples).

Operators have access to patients' ePHI and must not take snap-shots, screenshots or pictures (e.g. using another device) of any information viewed through the device.

Operators should not enter identifying data into the device. All the data on the device should be de-identified and relate to the sample id and not to the patient.

Reporting Device Security or Privacy Breaches

Operators must contact their local IT department and disclose any suspected or confirmed compromised user accounts, and any other privacy or security breaches.

Recovering from Compromised Accounts or Devices

When accounts are considered compromised, devices are lost, or unauthorized access is discovered or suspected, the Healthcare Organization's IT network administrators suspend and modify the user login criteria and issue new login credentials for the user to access their account securely.

Unavailable Service

Users should report unavailable service or prohibited access to information to their local Healthcare Organization's IT department.

Precautions

To ensure cyber security in order to the usage of the device, the following security measures should be considered. Contact your computer administrator:

Precautions for access control of the computer

- ➔ Secure the computer with a password (for example at Windows start up).
- ➔ Choose a complex password: A good password should be at least eight characters long and are not in the dictionary. In addition to letters, it should also include numbers and special characters.
- ➔ Do not choose a name or device name for a password (for example "Pentacam").
- ➔ Change the password regularly.
- ➔ Do not note the password in an accessible location.
- ➔ Use different passwords for different users.
- ➔ Enable the screen saver and use the option for the necessity of reentering the password when exit the screen saver.
- ➔ Choose an adequate time setting for starting the screen saver if software session is inactive (e.g. 10 minutes). Adequate time setting

should consider duration of examination, number of patients, time between examinations, use of other devices in the examination room, several user, etc.

- ➔ Lock the computer if you are leaving the workstation (shortcut: 'windows logo key' + 'L').

Precautions if the computer is connected to a LAN or internet network

- ➔ If you elect to connect the computer to the LAN or internet, you are responsible for ensuring data security.
- ➔ Prefer wired connections of the computer to the network.
- ➔ If you are using Wi-Fi connections nevertheless, please ensure the usage of adequate security methods (for example WPA2/AES – Wi-Fi Protected Access / Advanced Encryption Standard – with a strong network key).
- ➔ The usage of a firewall (software or hardware) is recommended.
- ➔ Heed the instructions for integration into an IT-Network ([sec. 20.5, page 83](#)).



Do not use the Pentacam[®] AXL with wireless technology, for example with wireless USB (connection between device and computer).

5 Intended Use



Attention

Federal law restricts this device to sale by or on the order of a physician.

The Pentacam® AXL is designed to take photos of the anterior segment of the eye which includes the cornea, pupil, anterior chamber and lens of the eye. To evaluate:

- corneal shape,
- analyze condition of the lens (opaque crystalline lens),
- analyze the anterior chamber angle,
- analyze anterior chamber depth,
- analyze the volume of the anterior chamber,
- analyze anterior or posterior cortical opacity,
- analyze the location of cataracts (nuclear, sub capsular and or cortical), using cross slit imaging with densitometry,
- corneal thickness,
- axial length,
- white-to-white distance.

The Pentacam® AXL also performs calculations to assist physicians in determining the power of the intraocular lens for implantation.

Intended medical indication

The Pentacam® AXL is indicated as an aid to screen several eye diseases e.g but not limited to:

- Keratoconus classification and progression
- Early ectatic diseases
- Quantification of optical corneal density
- Quantification of optical lens density
- Close angle glaucoma
- Planning support for IOLs.

The Pentacam® AXL may only be used for the purpose described in this instruction manual.

- ➔ Heed the safety instructions listed above.

Contraindication

none known

Possible side effects

- After-image
- Headache
- Vertigo
- Tearing eyes

Intended users

Make certain that the Pentacam[®] AXL is used exclusively in clinics and by clinical persons or eye specialists.

- who can guarantee proper handling due to their knowledge, training and practical experience.
- who have been instructed by OCLUS staff or an authorized dealer before the initial operation.

Patient group

Children from 3 years up to not limited. No restrictions on weight, health and condition: Patient is awake and able to understand and to look into a fixation target.

6.2 How the Pentacam® AXL works

While rotating around the eye, the Pentacam® AXL captures Scheimpflug images of the anterior eye segment through varying axes. The Scheimpflug images created during an examination are transmitted to the connected PC.

The axial length of the eye is measured and displayed by interferometry. Scheimpflug images can be captured at two seconds.

Up to 138,000 genuine height values are measured and analysed from the Scheimpflug images.

The Scheimpflug images are the basis for the height data which are used to calculate a mathematical 3D model of the anterior eye segment. At same time any eye movements are recorded and taken into account.

A quality specification (QS) lets you gauge the quality of the measurement taken.

The mathematical 3D model, corrected for eye movements, provides the basis for all subsequent analysis.

The topography of the front and rear surfaces of the cornea and the pachymetry are calculated and displayed from limbus to limbus for the entire surface of the cornea.

An analysis of the anterior chamber provides the basis for calculating the chamber angle, chamber volume and chamber depth.

Densitometry of the cornea and lens automatically produces quantified values.

Colour images displayed on the screen show the results of the measurement.

A rotatable 3D model displays the front and rear surfaces of the cornea, the iris and the lens.



Attention

OCULUS Optikgeräte GmbH shall not be liable in any form for further use of the data recorded by a Pentacam® AXL and for the evaluations it has calculated.

7 Setup and Connection



Attention

Risk of incorrect measurements/equipment damage due to improper setup

- Before first use, make sure the installation and connection of the Pentacam® AXL are completed by our service or by a professional authorized by OCULUS.
-



Note

- Do not expose the Pentacam® AXL to any vibrations, shocks, contaminants, moisture, or high temperatures.
 - Handle the optical device with care.
-

- Set up the Pentacam® AXL so that the power plug is easy to access. That way, you can easily disconnect it from the power supply for any repairs or maintenance work.
- Place the device so that direct light cannot affect the measurement.
- Make sure the examination is free from light reflections. To achieve this, darken the examination room.

Ambient temperature

The ambient conditions for operation are given in [sec. 19, page 72](#).

- Before installing the Pentacam® AXL, consider the transport, storage and current room temperature, where the device is to be installed. The difference between the temperature of the installation room and the storage and transport temperature should not be more than 10°C to avoid fogging of the internal optics.
- If the difference in temperature is greater than 10° C, leave the system at least for 6 hours until the temperature of the instrument has adapted to room temperature.

7.1 Electrical Connection



Attention

Electrical safety hazard

- ➔ Do not use the Pentacam® AXL adjacent to or stacked with other equipment.
- ➔ If you have to use the Pentacam® AXL adjacent to or stacked with other equipment, verify the correct operation of the Pentacam® AXL.
- ➔ Only use the power adapter listed in the list, [sec. 20.1, page 75](#).
- ➔ If you use a power strip to connect the Pentacam® AXL: Use a power strip that complies with the requirements of DIN EN 60601-1.
- ➔ Do not place the multiple socket extension cord on the floor.
- ➔ Do not use more than one multiple socket extension cord.
- ➔ Plug only the Pentacam® AXL and the computer that is being used with the unit (if applicable) into the multiple socket extension cord.
- ➔ Use a socket with a protective earth connection which is fully operating.



Fig. 7-1: Connecting

- ➔ Plug the connector of the Y cable into the jack and tighten the connection. Make sure that the plug is inserted in the correct position.



Note

Risk of equipment damage due to incorrect connection

If you do not connect the Pentacam® AXL properly, and the connection is live, the unit can be damaged within a short period of time.

- Do not use excessive force when connecting the electrical plug.
- Pay attention to the specifications on the nameplate.

If the electrical plug is damaged, contact our service department or an authorized distributor to repair the damage.

- Firmly tighten the connection.
- Connect the Y-cable to the PC/laptop and the power adapter.

7.2 Switching On



Attention

Risk of incorrect measurements due to improper setup

- Before taking measurements, the Pentacam® AXL has to be switched on, at least for one hour.

- The first step is to switch on the PC or laptop.
- Then turn on the Pentacam® AXL with the on/off switch (position ON). The LED on the switch lights up green, *fig. 7-1, page 19*.

7.3 Switching Off

- Close the Pentacam® AXL program and close the Patient Data Management.
- Shut down the Windows operating system.
- Turn the Pentacam® AXL off with the on/off switch (OFF position)

7.4 Software Installation on separate PCs

The Pentacam-Software is network compatible. This makes it possible to install the Pentacam® AXL Software on several PCs, connected in a local network.

Make sure, that all PC in a network do have the same Pentacam® AXL software version installed.

A Floating License Key is part of every Pentacam® AXL shipment. Please ensure a proper installation based on the Manual for the Floating License Key.

This allows an interactive parallel evaluation of the Pentacam® AXL exams based on the released optional software packages and modules.

The demo examinations included can be viewed on every computer having the Pentacam® AXL software installed.

For more detailed information contact your authorized distributor or our service department.

8 Patient Data Management

8.1 Starting Patient Data Management

You can enter and use the patient data by the patient data management. After you have switched on the PC, it first loads the operating system.

➔ Click the Pentacam® AXL icon.

The user interface for the Patient Data Management appears.

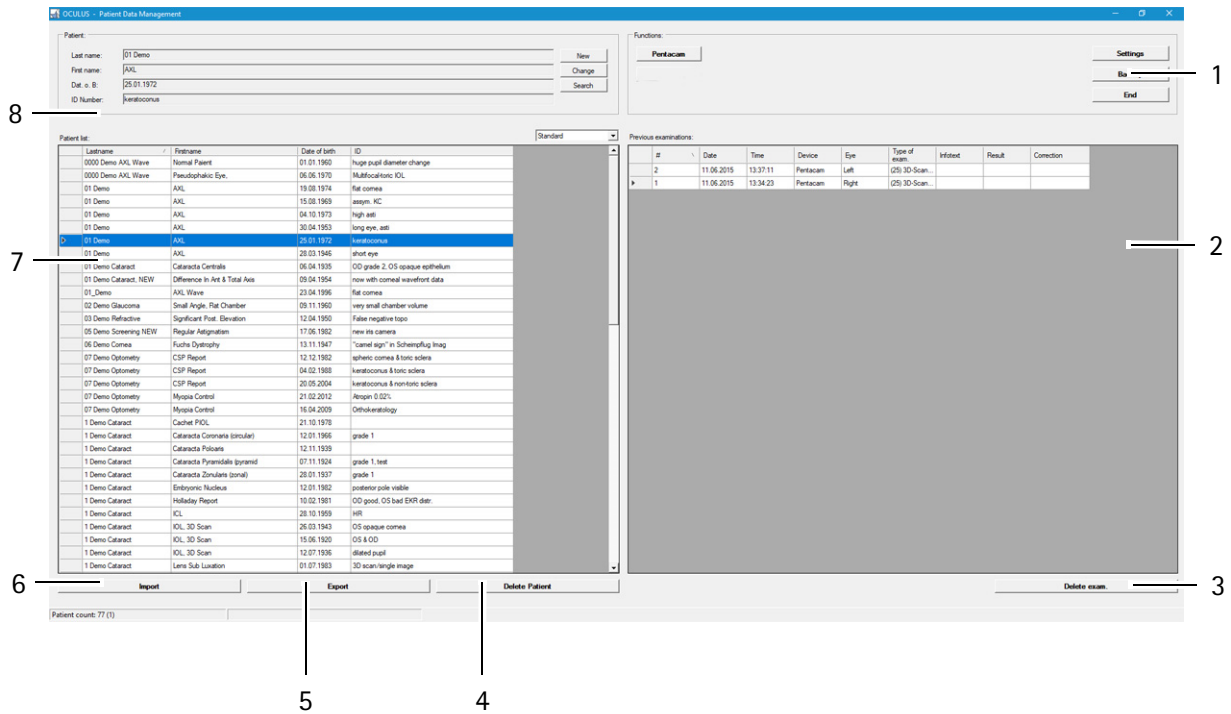

- 1 "Functions" group box
- 2 Previous examinations
- 3 [Delete exam.] button
- 4 [Delete Patient] button

- 5 [Export] button
- 6 [Import] button
- 7 Patient list
- 8 "Patient" group box

Fig. 8-1: Patient Data Management user interface



To get to the Pentacam® AXL program, you must first enter a new patient (8) or select an existing patient from the patient list (7).

For more information on Patient Data Management, refer to the [sec. 12, page 52.](#)

8.1.1 Entering a New Patient

➔ Press the [New] button to enter a new patient in the Patient Data Management system.

- ➔ Enter the patient's last name, first name and date of birth in the patient window.

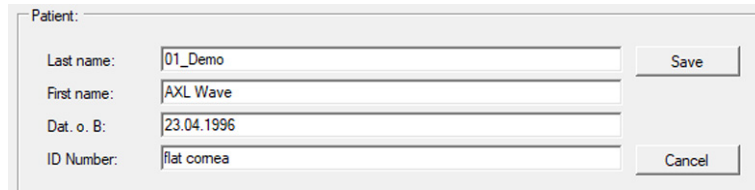

Fig. 8-2: Entering patients

Optionally you can enter an ID number for the patient.

- ➔ To save the data you entered, click [Save].
- The patient you have just entered now appears in the patient list.

8.1.2 Selecting an Existing Patient

The patient data list on the left-hand side of the screen displays all previously examined patients in alphabetical order.

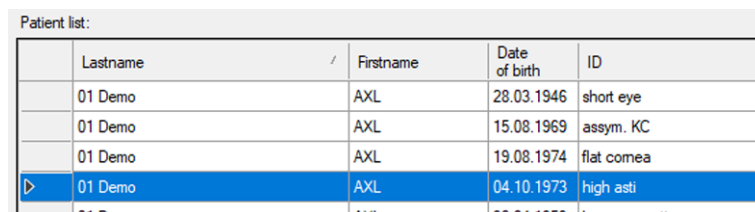

	Lastname	Firstname	Date of birth	ID
	01 Demo	AXL	28.03.1946	short eye
	01 Demo	AXL	15.08.1969	assym. KC
	01 Demo	AXL	19.08.1974	flat cornea
▶	01 Demo	AXL	04.10.1973	high asti

Fig. 8-3: Patient list

- ➔ Choose [Search] to quickly find the patient you are looking for in the list.
- ➔ Enter the patient's name or the first letter of the name in the "Last name" field.
Alternatively, you can search for the patient using an ID number, first name or date of birth, assuming that one was assigned when the patient was first recorded.
- ➔ In the list that appears, click the entry you were searching for to transfer the patient's name to the patient window. This also brings up a list of any previous examinations for that patient in the examination window (bottom right side).
- ➔ Click on "End Search" to finish that process. The respective patient is still highlighted in blue.

Extended Patient Search: [Extended] Checkbox

➔ Click on the [Extended] checkbox.

The screen displays additional search parameters which reference previous examinations. Proceed as for the input of a patient name.

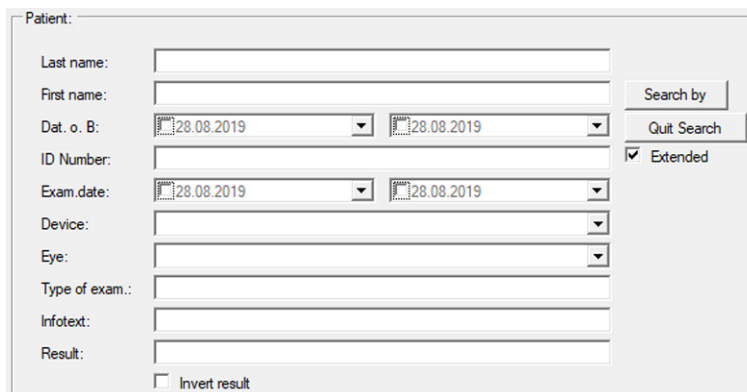

The screenshot shows a search form titled "Patient:". It contains the following fields and controls:

- Last name: [Text input field]
- First name: [Text input field]
- Dat. o. B.: [Date dropdown] 28.08.2019 [Date dropdown] 28.08.2019
- ID Number: [Text input field]
- Exam.date: [Date dropdown] 28.08.2019 [Date dropdown] 28.08.2019
- Device: [Dropdown menu]
- Eye: [Dropdown menu]
- Type of exam.: [Text input field]
- Infotext: [Text input field]
- Result: [Text input field]
- [Search by] button
- [Quit Search] button
- Extended checkbox
- Invert result checkbox

Fig. 8-4: Extended search

8.2 Starting the Pentacam® AXL Software

Switching from Patient Data Management to the Pentacam® AXL program:

➔ After selecting a patient: Press the [Pentacam] button to start the Pentacam® AXL program (*fig. 8-1, page 22*)

or

➔ Double-click the selected patient name or an examination to start the Pentacam® AXL program.



Proceed a test measurement if a message appears, *sec. 13, page 57*.

If you do not proceed a test measurement, it will be stored in the Pentacam® AXL program.

9 Pentacam® AXL Program

If no error message appears after starting the software with the device connected and switched on (for example component failure, camera not detected, missing references data, etc.), the device is safely ready for operation.



Note

The Pentacam® AXL program is not to be used to dictate therapy without professional correlation with other clinical findings and diagnostic tests.

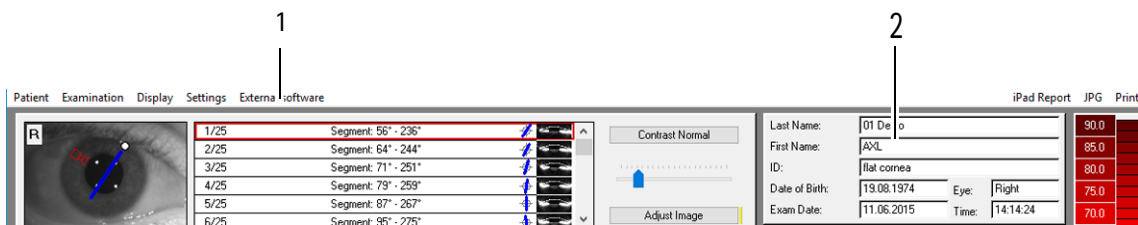

1 Menu bar

2 Examination and Patient data

Fig. 9-1: Pentacam® AXL program menu (upper section)

Loading previous examinations

- ➔ Select the menu item [Examination] and click [Load].
The dialog box "Load Examination" appears.
- ➔ Make a selection by clicking the required examination.
- ➔ Confirm your selection by clicking [OK], or by double clicking.
The Pentacam® AXL program will load the examination you have selected.

Starting a measurement

- ➔ Select the [Examination] tab and click [Scan].
The blue slit light is activated and the Scan menu ([sec. 10, page 27](#)) appears.



Note

As this instruction manual focuses on the Pentacam® AXL operating concept, the description of Pentacam® AXL program functions is limited to starting the measuring process and loading previous examinations. The Reference manual contains detailed information on the functions of the Pentacam® AXL program.



Helpful information

The Pentacam® AXL program provides you a direct help. You can recognise that by a yellow mark.

This symbol appears for some measured values.

➔ Click on this symbol to show the corresponding message.

You must check the corresponding measured value.

10 Scan Menu

Switching from the Pentacam® AXL program to the Scan menu:

- ➔ In the Pentacam® AXL program (*fig. 9-1, page 25*) select the menu item [Examination] and click [Scan].

10.1 Screen layout

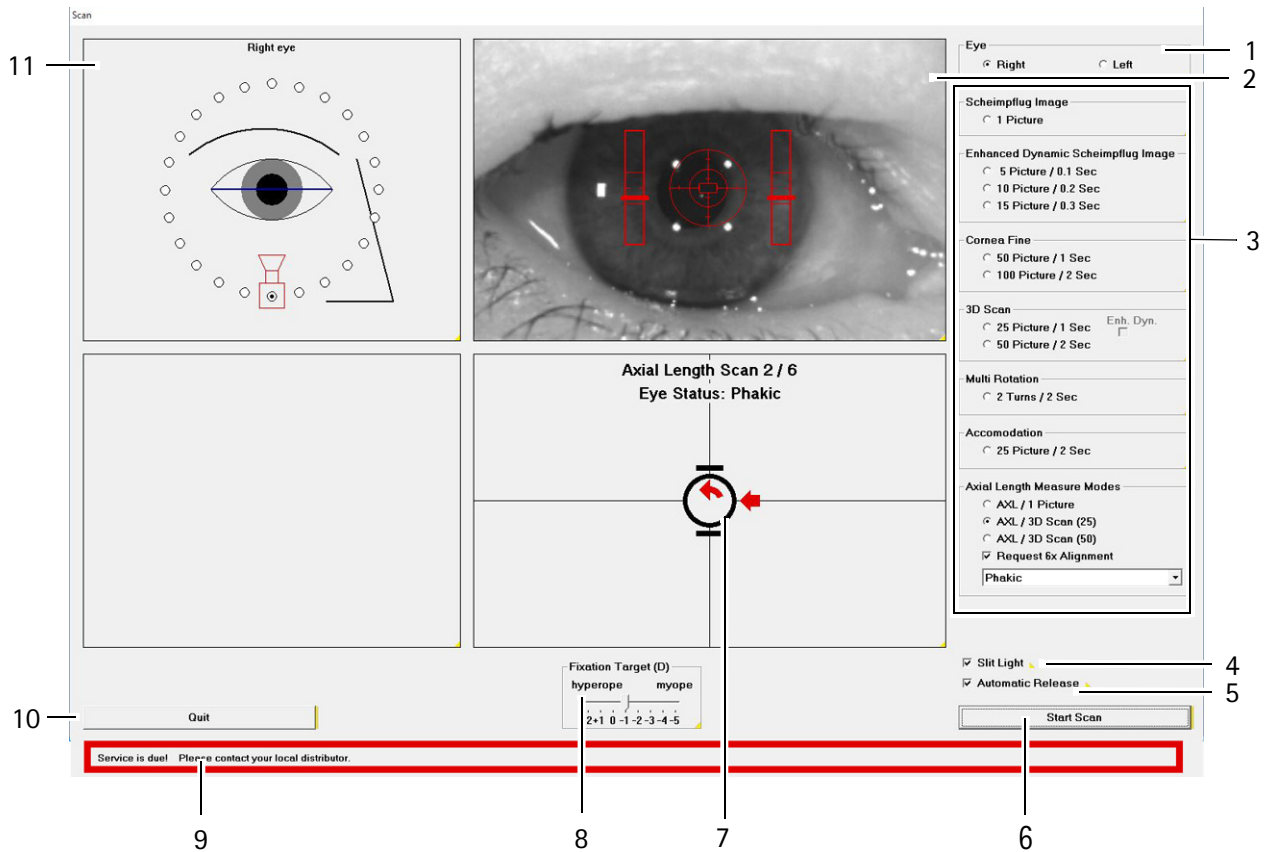

- | | |
|-------------------------------------|------------------------|
| 1 "Eye" field | 7 Adjustment window |
| 2 Overview image with adjusting aid | 8 Fixation Target |
| 3 "Image Options" area | 9 Message about device |
| 4 [Slit Light] checkbox | 10 [Quit] button |
| 5 [Automatic Release] checkbox | 11 "Orientation" field |
| 6 [Start Scan] button | |
- Fig. 10-1: "Scan" screen

- The eye currently being examined is detected automatically and is displayed in the "Eye" field (1).
- The Overview image (2) shows the pupil and a cross hair as an adjusting aid.
- You can set the type of image required for the respective examination in the "Image Options" area (3) (*sec. 10.1.1, page 28 and sec. , page 29*).
„Axis Length Measure Modes“: Click a button to enable a

measurement of the axial length. Select the eye status in the corresponding dropdown list.

Eye Status:

- Phakic: Default status. Presence of crystalline lens.
- Aphakic: Absence of the crystalline lens.
- Pseudophakic (Silicone IOL or similar): IOL of silicone or similar material implanted.
- Pseudophakic (Acrylate): Intraocular lens made of Acrylat/Meatacrylate.
- Pseudophakic, silicon-oil filled, after vitrectomy: previous vitrectomy with a silicon-oil-filled vitreous.
- Click the [Slit Light] checkbox (4) to activate/deactivate the blue light for illuminating the eye.
- Click the [Automatic Release] checkbox (5) to activate automatic measurement.
- Clicking the [Start Scan] button (6) activates manual measurement. You can also use the Return key.
- Inside the adjustment window (7), there are arrows showing you the direction in which you have to move the Pentacam® AXL to activate automatic measurement (Automatic Release).
- The "Fixation Target" setting (8) is a parameter to optimize the fixation.
- This line (9) shows messages about the device, for example if a service is due.
- Click the [Quit] button (10) to abort the measurement.
- The "Orientation" field (11) shows the respective position of the camera and the eye, which is currently being examined.

10.1.1 Scheimpflug image settings

You can set the number and type of images required for the respective examination in the "Image Options" box (3).

"Scheimpflug Image" group box

- If you activate this option, the camera records only one Scheimpflug image. You can freely select the camera position you require by clicking the white rings in the "Orientation" field (11).

"Enhanced Dynamic Scheimpflug Image" group box

- Use this option to make the camera record either 5, 10 or 15 Scheimpflug images, with the camera remaining in the same position. Image averaging is carried out on the recorded images to minimise background noise. Only one Scheimpflug image is displayed. You can freely select the camera position you require by

clicking the white rings in the "Orientation" field (11). This type of image is suitable for a purely densitometric assessment of the lens.

"3D Scan" group box

- Use this option to select how many images you want the camera to record per scan. The difference is in the duration of the examination and the number of measuring points that are evaluated. A scan comprising 50 images takes longer of the patient provides the highest amount on measured elevation data. This type of examination is used for evaluating the cornea and anterior chamber.

"Cornea Fine" group box

- Select this option for a more detailed image of the cornea. The camera does not capture the deeper-lying layers of the front part. You can select 50 Scheimpflug images for a recording time of one second, or 100 Scheimpflug images for a recording time of two seconds.

"Multi Rotation" group box

- If you select this option, the camera will record Scheimpflug images from 50 different positions while performing a full rotation twice around the eye.

"Accommodation" group box

- If you select this option, the camera will take a total of 50 Scheimpflug images. While the camera is recording the images, the "Fixation Target" shifts constantly from -5 D to +2 D. The camera records the Scheimpflug images from a pre-selected camera position.

"Axial Length Measure modes" group box

- ➔ Select this option for measuring the axial length. If you select this option, the desired mode for the axial length measurement is enabled.
- ➔ Follow the instructions on the screen to align the patients eye to the Pentacam® AXL. If the patients eye is aligned to the Pentacam® AXL properly the Pentacam® AXL measures six times the axial length of the patients eye.
- ➔ Read the message on the screen and give the patient a break for blinking.
- ➔ Advise the patient to watch on the red blinking light. Click on the OK button to proceed with the 3D scan.
- ➔ Follow the instructions on the screen to align the patients eye to the Pentacam® AXL properly.

If "Request 6x Alignment" is activated, the axial length measurement starts only if the patient is fixating correctly during the complete scan. After the Pentacam® AXL is aligned properly, the measurement starts automatically.

"Request 6x Alignment" deactivated means: The axial length measurements are performed without any interrupt.

"Request 6x Alignment" is activated by default and should just be deactivated if the patient has problems to fixate the red blinking light.

[Enh. Dyn.] checkbox in the "3D Scan" group box

- Activating the "Enh. Dyn." function prolongs the exposure time per Scheimpflug image. The advantage is an accurate representation of phakic IOLs. If you select this recording mode, colours and evaluations are neither calculated nor displayed.

"Fixation Target" slider

- Use of the "Fixation Target" enables a better fixation of the patient. For this, the active "Fixation Target" (8), i.e. the LED blinking red in the middle of the blue slit, can be shifted in steps of 0.5 D. The object is to offset defects in the patient's vision and ensure a simpler method of fixation.

10.2 Information for recording Scheimpflug images

Type of examination	Examination mode	Images	Automatic measurement	Notes
Topography	3D scan	25-50	Yes	
Pachymetry	3D scan	25-50	Yes	
Analysis of the anterior chamber	3D scan	25-50	Yes	Do not apply mydriatic drops.
Densitometry	3D scan	25-50	Yes	Use the same number of images to enable a progress check, apply mydriatic drops
Axial length	AXL	6	Yes	Pay attention to eye status.

11 Measuring Procedure

This to

- to measure the axial length, *sec. 11.1, page 31*
- for the anterior segment of the eye, *sec. 11.2, page 39*



Attention

Risk of incorrect measurement due to incorrect use

- ➔ Before first use: Let OCULUS or an authorized distributor train you in the operation of the Pentacam® AXL.

Risk of incorrect measurements due to improper setup

- ➔ Before taking measurements, the Pentacam® AXL has to be switched on, at least for one hour.

Risk of incorrect measurement caused by little movements of the patient.

Due to the little movements caused by the wheel chair or rolling stool the patient is not proper aligned to the Pentacam® AXL.

- ➔ Perform a Pentacam® AXL scan just if the patient sits in a stationary chair. In cases of wheel chairs lock the brakes.

11.1 Measuring Procedure to Measure the Axial Length

Before the measurement

It is mandatory to select the correct eye status before every axial length measurement. Different eye status lead to different results for the axial length measurement, hence influence the IOL power calculation. The examiner has to select the eye status before every axial length scan.

Select Eye Status

Please select the status of the patients right eye:

Phakic

Aphakic

Pseudoph. (Silicone IOL and similar)

Pseudoph. (Acrylate IOL)

Pseudoph., silicone-oil-filled, after vitrectomy

- ➔ To select the eye status open the scan menu and click on "Eye status"

- Phakic: Default status. Presence of crystalline lens.
- Aphakic: Absence of the crystalline lens. Correction of measured axial length by +0.200 mm
- Pseudophakic (Silicone IOL or similar): IOL of silicone or similar material implanted. Correction of axial length by +0.120 mm.
- Pseudophakic (Acrylate): Acrylat/Metaacrylate IOL implanted. Correction of axial length by +0.110 mm.
- Pseudophakic, silicon-oil filled, after vitrectomy: previous vitrectomy with a silicon-oil-filled vitreous. Correction of axial length by -0,692mm

Consider past corneal treatments such as PRK, LASIK, RK etc., as

→ special IOL power calculation formulas may be necessary.



Attention

Risk of incorrect measurement caused by unchecked plausibility

→ Check both eyes on plausibility.

Recommended differences between both eyes should be below:

- Axial length AXL <0,3mm
- Curvature < 0,18mm equals approximately in 1D (based on a refractive index of 1,3375)
- Difference of IOL power to reach emmetropia by same target refraction <1D

The following conditions may influence the readings of the measurement respectively make it impossible:

- Deep cataracts, opaque corneas in the optical center, severe fixation problems.

Note: In pseudophakic eyes the anterior chamber depth is not declared but it is possible to measure the anterior chamber depth in the Scheimpflug images manually.

Default settings

→ Start the Scan menu (*fig. 10-1, page 27*).

→ Make sure that the button "Automatic Release" is activated.

→ Make sure that the button "Request 6x Alignment" is activated.

If "Request 6x Alignment" is activated, the axial length measurement starts only if the patient is fixating correctly. The measurement starts automatically. "Request 6x Alignment" deactivated means: The axial length measurements are performed without any interrupt.

"Request 6x Alignment" is activated by default. Just deactivate "Request 6x Alignment" if the patient has strong problems with fixation.

→ Adjust the table height.

- ➔ Check that
 - fresh paper has been put onto the chin rest or the chin rest has been cleaned and disinfected, *sec. 14, page 62*.
 - the forehead rest has been cleaned and disinfected after each examination, *sec. 14, page 62*.
 - the optical window is clean.
- ➔ Ask the patient to place his or her head on the chin and forehead rest.
- ➔ Do not touch the patient and the Pentacam® AXL simultaneously.

Rough adjustment

- ➔ The black ring marking between the chin rest and the forehead rest (1) should be used for gauging the required height of the patient's eyes.

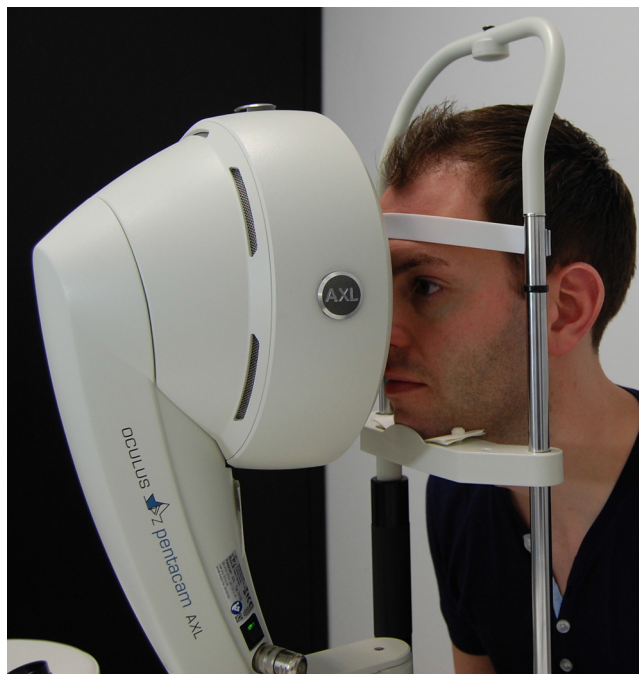

1 Marking (black ring)

2 Twist grip

Fig. 11-1: Rough adjustment of the chin and forehead rest

- ➔ Adjust the patient's eye level using the twist grip (2).
The patient is positioned correctly when chin and forehead touch the rests and the eyes are level with the marking.



If you adjust the chinrest for a small head (for example: a child's head), the test eye may stop the chinrest. Swing the test eye to the side and then adjust the chinrest.

- ➔ Example of a rough adjustment for the right eye: Move the cross slide (1) until the marking at the end of the cross slide roughly coincides with the circle R (3) on the sliding plate.

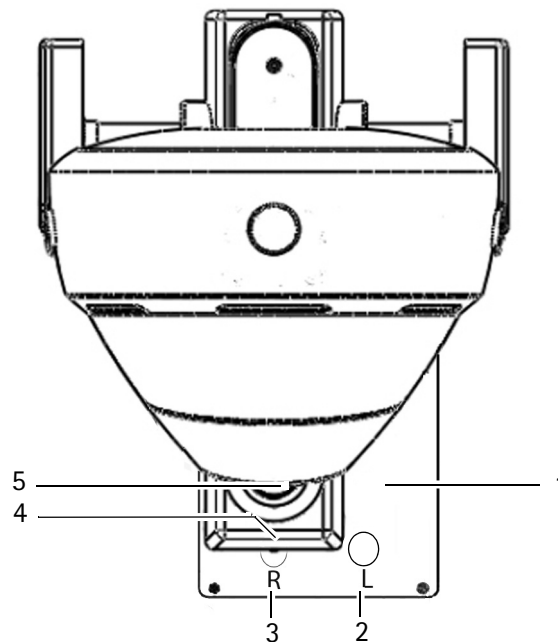

- | | |
|-----------------|------------------------------|
| 1 Cross slide | 4 Marking on the cross slide |
| 2 Left marking | 5 Joystick |
| 3 Right marking | |

Fig. 11-2: Markings on the cross slide

- ➔ Look at the patient's eye you are examining from one side and make sure that his/her eye is in front of the measuring window.
- ➔ If necessary, adjust the position of the cross slide to the left or right.

Darkening the room/dark sheet

- ➔ If the lighting in the examination room has not been turned down or switched off, use the dark sheet supplied to cover the patient and the Pentacam.
- ➔ Advise the patient to look at the red fixation target/point.

Adjustment

- ➔ Move the image with the cross towards the patient until the four infrared LED are clearly to see.

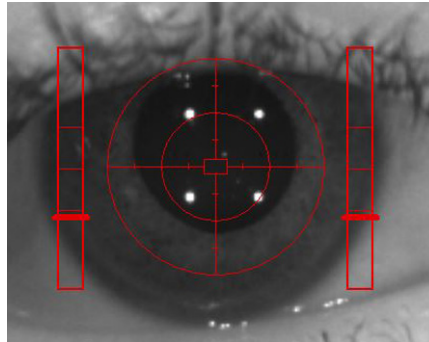

Fig. 11-3: Overview image

- ➔ Focus the pupil image by moving the joystick towards the Pentacam® AXL or away from it.
The bars on the right and left of the pupil will support you to find the correct position. The closer the marks to the middle of the bars are the better is the adjustment.
- ➔ Adjust the left/right position of the Pentacam® AXL and its height setting.
Move the joystick to the left or right and rotate the joystick clockwise or anticlockwise.
The tentative final position of the camera is reached when the central corneal reflex is in the center of the box of the red cross hair.
- ➔ Shortly before you have reached the final position ask the patient to widen his or her eye and not to blink.

The Pentacam® AXL triggers the measurement automatically.

You can use the adjusting aid of the fine adjustment alternatively, see

"Fine adjustment" page 44.

Fine adjustment

→ Make any fine adjustments required based on the information in the adjustment window.

Example (with grey arrows): distance to patient's eye is not correct.

→ Move the device towards or fromward the patient.

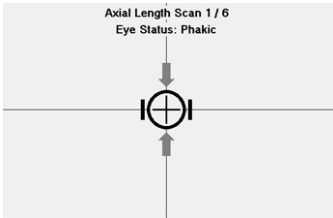

Example (with red arrows): Move or rotate the joystick in the specified directions.

→ Move the joystick to the right.

→ Turn the joystick counter clockwise.

→ Move the joystick forwards.

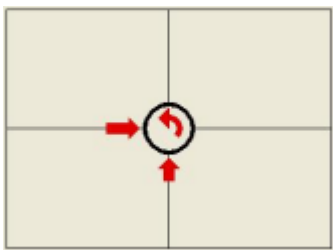

Arrow	Camera movement	Joystick movement
→	right	Move the joystick to the right
←	left	Move the joystick to the left
↑	forward	Move the joystick toward the patient
↓	back	Move the joystick away from the patient
↻	up	Rotate the joystick clockwise
↻	down	Rotate the joystick counter-clockwise

When you have achieved the expected position, a black cross will appear in the centre of the ring, surrounded by four black lines. The Pentacam® AXL will automatically begin measuring, alternately you can start the measuring procedure manually.

→ For measuring manually: Start measuring by clicking [Start Scan] or by pressing the return key.



Attention

It may not be possible to carry out a measurement with manual release.

→ Ask the patient to blink normally, take a short break and proceed with the 3D Pentacam scan.

→ Follow the instructions on the screen and then continue with the 3D scan.

➔ Go to measurement "Adjustment" page 43.

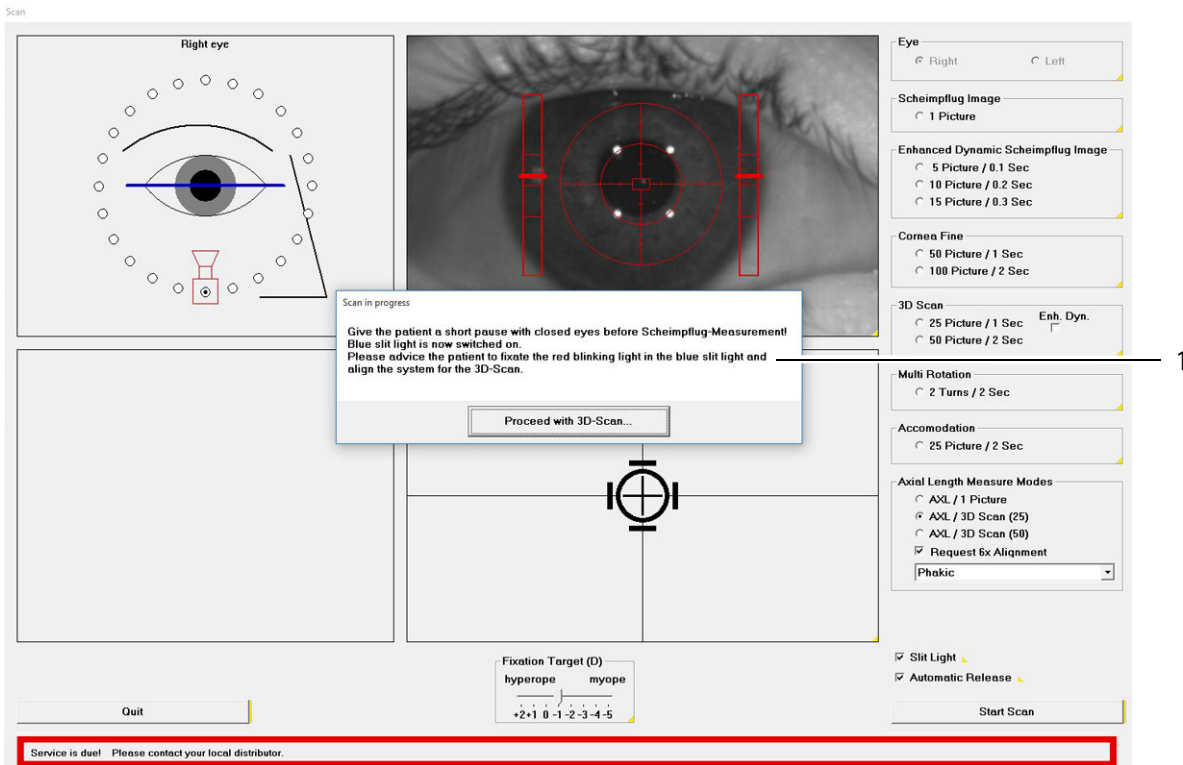

1 Message with instructions

Fig. 11-4: Pentacam® AXL: Proceed with 3D-Scan

During the measurement of both eyes the following messages may occur.

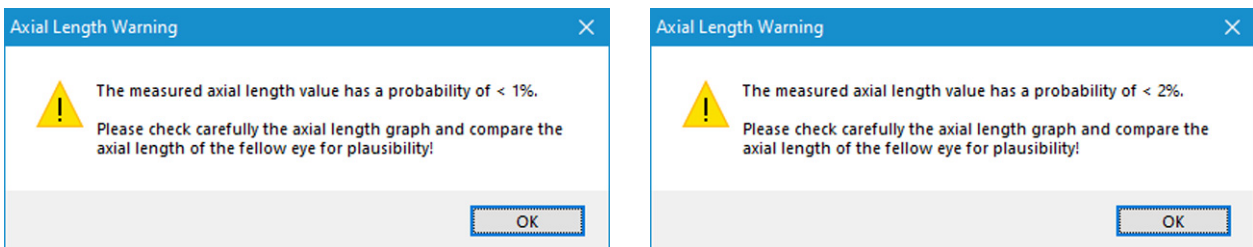

Fig. 11-5: Message: Plausibility check



Note

The axial length values do not correspond to the values of the normal population.

➔ Check the axial length values of both eyes.

The plausibility is marked by a yellow flagged QS value. This will be stored in the Pentacam® AXL programme accordingly.



This symbol, related to the messages appears for example in the IOL calculator.

➔ Click on this symbol to show the corresponding message.

You must check the corresponding measured value.

If the measured axial length value has a probability of $< 1\%$, the following message may occur.

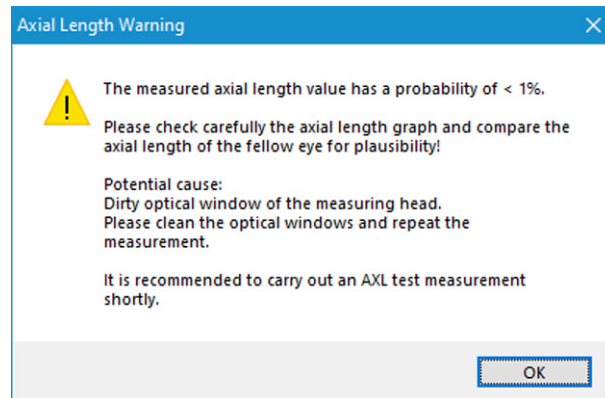

Fig. 11-6: Message: dirty optical window



Warning

Faulty measurements due to dirty window

- ➔ Clean the optical window.
- ➔ Carry out a test measurement.

If you do not carry out the test measurement, then this message will be stored in the Pentacam® AXL programme accordingly marked by a red flagged QS value, for example in the IOL calculator.

- ➔ Repeat the measurement.

You must check the corresponding measured value.

- ➔ Adjust the patient's eye level using the twist grip (*fig. 11-7, page 39, item 2*).

The patient is positioned correctly when chin and forehead touch the rests and the eyes are level with the marking.



If you adjust the chinrest for a small head (for example: a child's head), the test eye may stop the chinrest. Swing the test eye to the side and then adjust the chinrest.

- ➔ Example of a rough adjustment for the right eye: Move the cross slide (1) until the marking at the end of the cross slide (4) roughly coincides with the circle R (3) on the sliding plate.

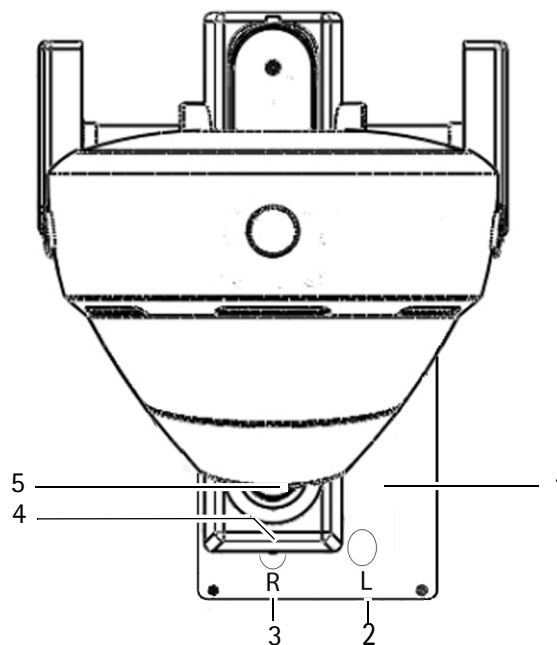

1 Cross slide

2 Left marking

3 Right marking

4 Marking on the cross slide

5 Joystick

Fig. 11-8: Markings on the cross slide

- ➔ Look at the patient's eye you are examining from one side and make sure that the blue slit light illuminates the cornea.
- ➔ If necessary, adjust the position of the cross slide to the left or right



Fig. 11-9: Slit light on the cornea



Note

If the blue slit light is not visible, ensure that you have activated the [Slit Light] checkbox on the "Scan" screen.

Darkening the room/dark sheet

- ➔ If the lighting in the examination room has not been turned down or switched off, use the dark sheet supplied to cover the patient and the Pentacam.

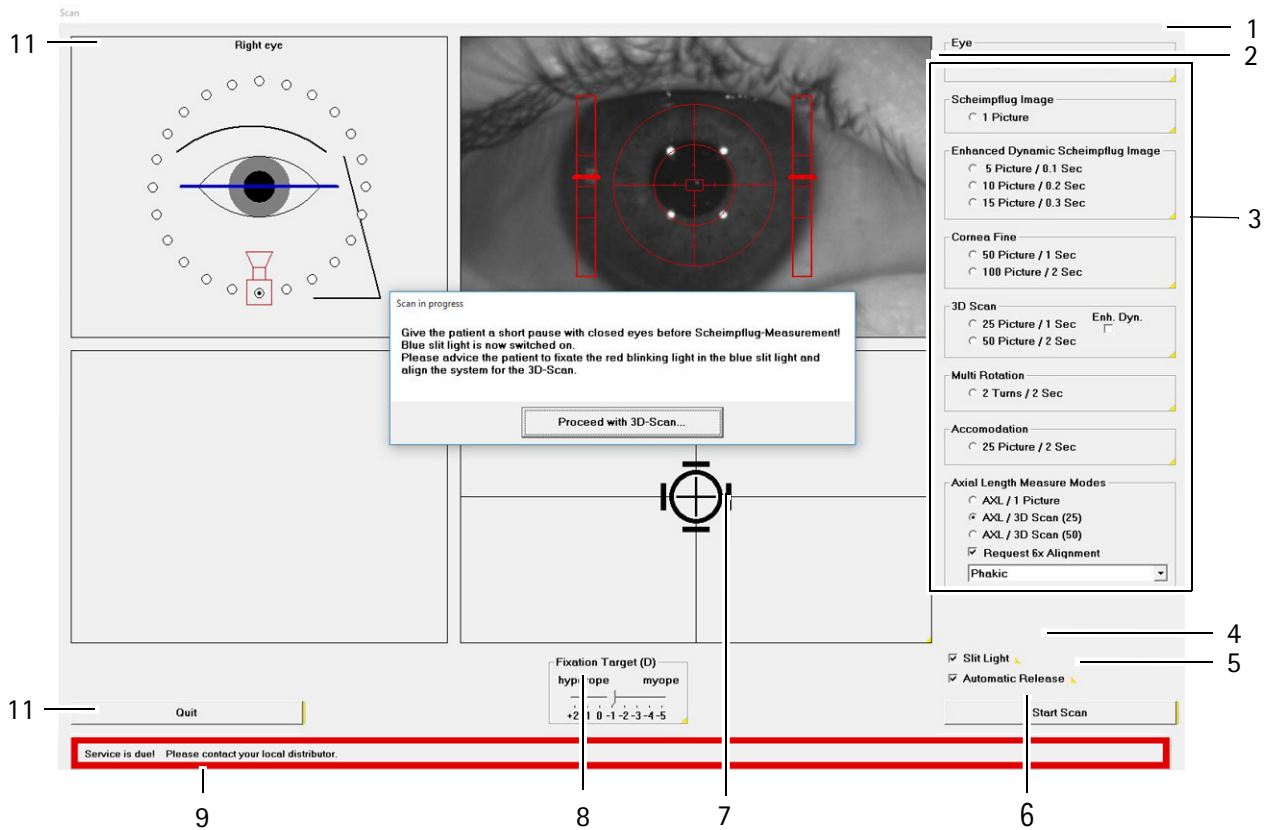

- 1 "Eye" field
- 2 Overview image
- 3 "Image Options" area
- 4 [Slit Light] checkbox
- 5 [Automatic Release] checkbox
- 6 [Start Scan] button
- 7 Adjustment window
- 8 Fixation Target
- 9 Message about device
- 10 [Quit] button
- 11 "Orientation" field

Fig. 11-10: "Scan" screen

Adjustment

- ➔ Move the cross slide towards the patient until the Scheimpflug image shows the cornea of the eye that you are examining.

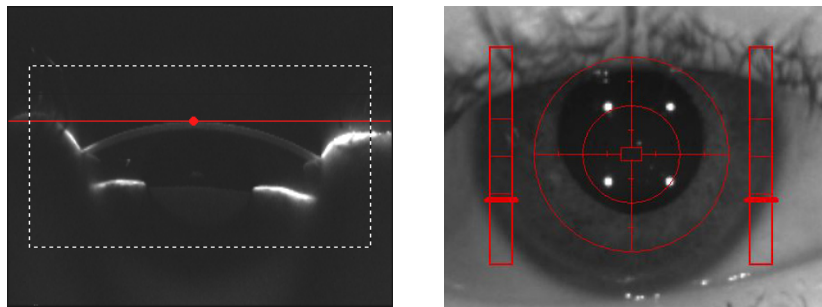

Fig. 11-11: Scheimpflug image (left)^{aa} and overview image (right)

- a. This screen is only available with a Pentacam® image without an axial length measurement

The image is sharpest when the red dot coincides with the red line in the Scheimpflug image (relevant for Pentacam® without an axial length measurement).

- ➔ Focus the pupil image by moving the joystick towards the Pentacam® or away from it.
- ➔ Adjust the left/right position of the Pentacam® AXL and its height setting.

Move the joystick to the left or right and rotate the joystick clockwise or anticlockwise.

The tentative final position of the camera is reached when the four infrared LEDs are sharp and the red cross hair is in the center of the pupil.

- ➔ Ask the patient to widen his or her eye and not to blink.

The Pentacam® AXL triggers the measurement automatically.





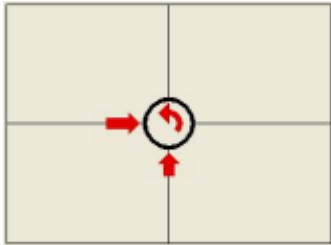

Fine adjustment

- Make any fine adjustments required based on the information in the adjustment window. To do so, move the joystick in the specified directions.



Example:

- Move the joystick to the right.
- Turn the joystick counter clockwise.
- Move the joystick forwards.

Arrow	Camera movement	Joystick movement
	right	Move the joystick to the right
	left	Move the joystick to the left
	forward	Move the joystick toward the patient
	back	Move the joystick away from the patient
	up	Rotate the joystick clockwise
	down	Rotate the joystick counter-clockwise



- When you have achieved the expected position, a black cross will appear in the centre of the ring, surrounded by four black lines. The Pentacam® will automatically begin measuring, alternately you can start the measuring procedure manually.
- For measuring manually: Start measuring by clicking [Start Scan] or by pressing the return key.



Attention

It may not be possible to carry out a measurement with manual release.

- Ask the patient to remove his or her head from the rest.
- Check the measurement results by referring to the quality specifications ([sec. 11.2, page 39](#)).

11.3 Quality Specifications

11.3.1 Quality Specifications in the Pentacam® AXL program

After you have measured either automatically or manually, the Pentacam® AXL program opens. The "QS" value appears in field (1).

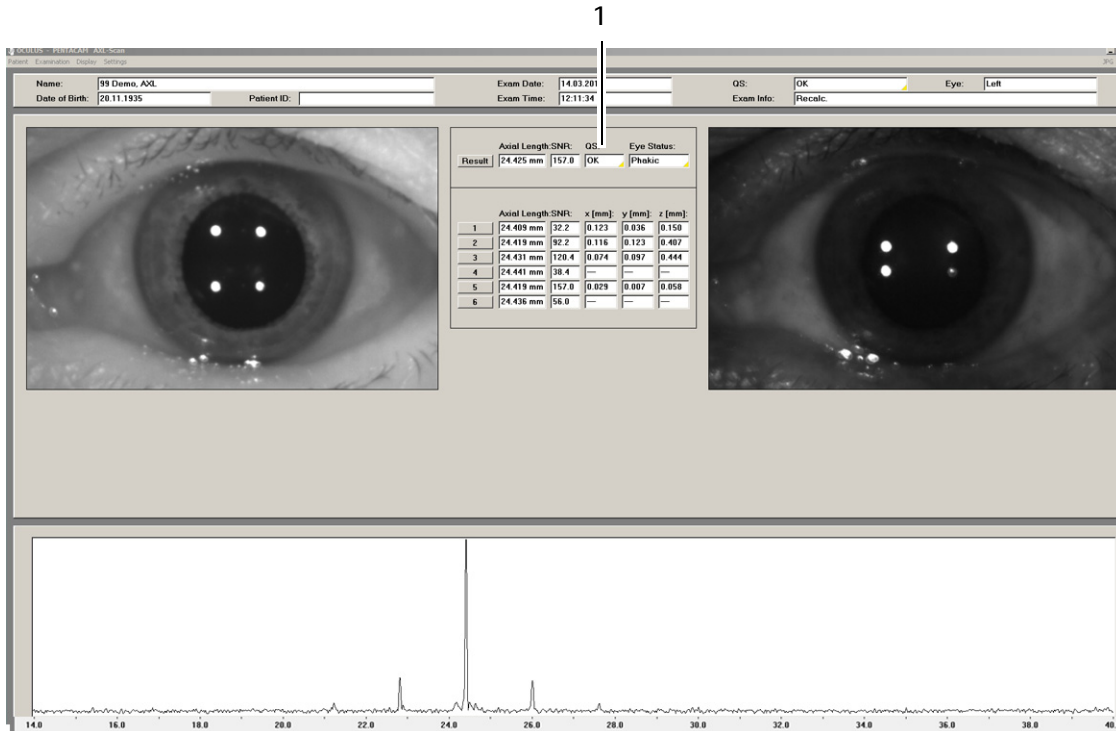

1 "QS" display

Fig. 11-12: Pentacam® AXL program with "QS" display



Note

All examinations are automatically saved, regardless of the quality of the measurement taken.

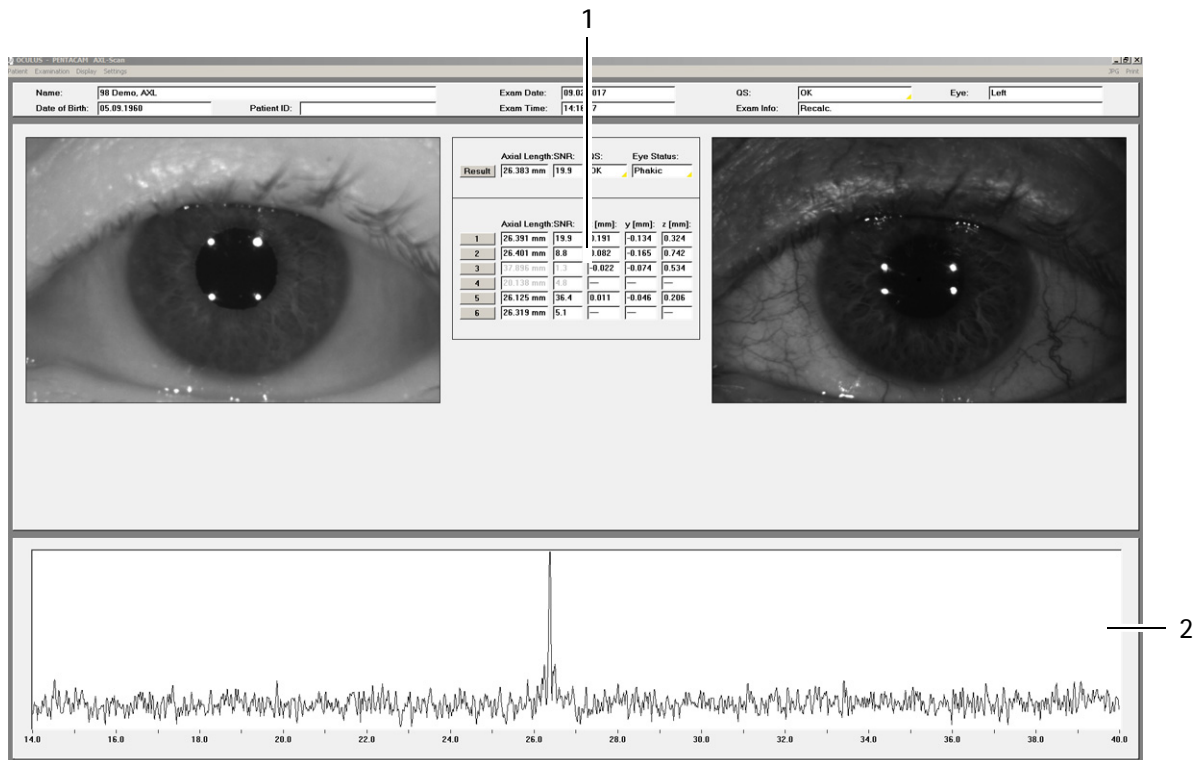

1 Single scans with with grey coloured values

2 Signal to noise ratio of the axial length measurement

Fig. 11-13: Display "AXL-Scan"

AXL scan data (1)

- **Axial length:** The final result of the axial length is calculated just of all feasible SNR peaks. If you push the button "Result" the signal curve of the best scan is displayed.
- **SNR:** Signal to noise ratio
 - reads OK, the measurement is correct and can be reproduced. SNR ≥ 6.3
 - is yellow, you may want to repeat the measurement. SNR ≥ 5.0
 - is red, must repeat the measurement. SNR < 5.0

If only one of six SNR values is valid, it will only be displayed as an red single value, even though the SNR value is above the limit.

- **1 – 6, x (mm), y (mm), z (mm):** Display of all six single scans with results. Via clicking on the numbered buttons the respective signal curves can be viewed.

Grey coloured values: In order to enhance the quality of measurements all single scans are screened to remove invalid signal peaks. These are displayed in grey colour and are not considered in the final result, see [fig. 11-13, page 46](#).

- **QS:** If the AXL scan data (1)

- reads OK, the measurement is correct and can be reproduced. SNR ≥ 6.3
 - is yellow, you may want to repeat the measurement. SNR ≥ 5.0
 - is red, must repeat the measurement. SNR < 5.0
- ➔ If the "QS" displays highlighted in yellow, click on the "QS" button.
The following dialog box appears:

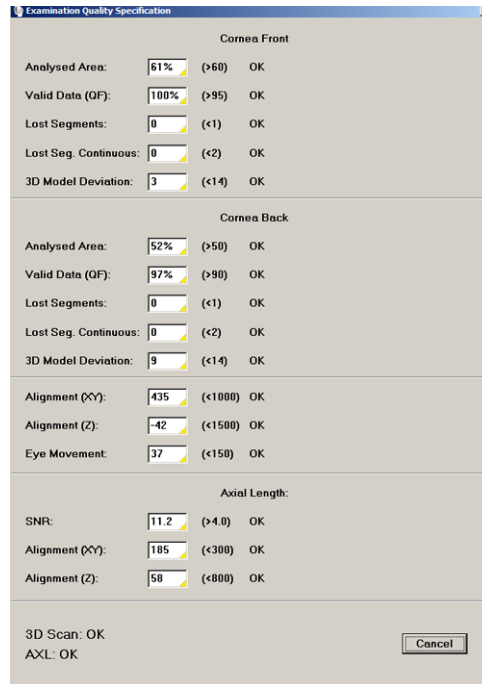

Cornea Front		
Analysed Area:	61%	(>60) OK
Valid Data (QF):	100%	(>95) OK
Last Segments:	0	(<1) OK
Last Seg. Continuous:	0	(<2) OK
3D Model Deviation:	3	(<14) OK
Cornea Back		
Analysed Area:	52%	(>50) OK
Valid Data (QF):	97%	(>90) OK
Last Segments:	0	(<1) OK
Last Seg. Continuous:	0	(<2) OK
3D Model Deviation:	9	(<14) OK
Alignment (XY):	435	(<1000) OK
Alignment (Z):	-42	(<1500) OK
Eye Movement:	37	(<150) OK
Axial Length:		
SNR:	11.2	(>4.0) OK
Alignment (XY):	185	(<300) OK
Alignment (Z):	58	(<800) OK

3D Scan: OK
AXL: OK

Cancel

Fig. 11-14: Examination Quality Specification

- ➔ Check the measurement results.
- ➔ If you have any doubts, repeat the measurement.

Notes on individual parameters

- **Analysed Area**
If this value is less than the permissible threshold, the patient must widen his or her eye.
- **Valid Data**
If this value is less than the permissible threshold, you must darken the room.
- **Lost Segments and Lost Seg. Continuous**
If one of these values exceeds the permissible threshold, you must ask the patient not to blink while you are measuring.
- **3D Model Deviation: deviation of measured cornea from calculated 3D model**
- **Alignment (XY) and Alignment (Z)**
If one of these values exceeds the permissible threshold, you may have moved the cross slide at the moment you began measuring.
- **Eye Movement**
If this value exceeds the permissible threshold, the fixation of the patient is inadequate.
- **SNR**
Signal to noise ratio

Terminating "QS"

- ➔ Click [Cancel] to return to the Pentacam® AXL program.
- ➔ If required, delete the measurement if the image is inadequate.
- ➔ Terminate the current examination which has been saved.
- ➔ If required, make preparations to examine another patient. In the "Pentacam" overview, select the "Examination" menu and click [New Patient/End].

11.3.2 Quality Specifications in the Pentacam® program

After you have begun measuring either automatically or manually, the Pentacam® program opens. The "QS" value appears in field (1).

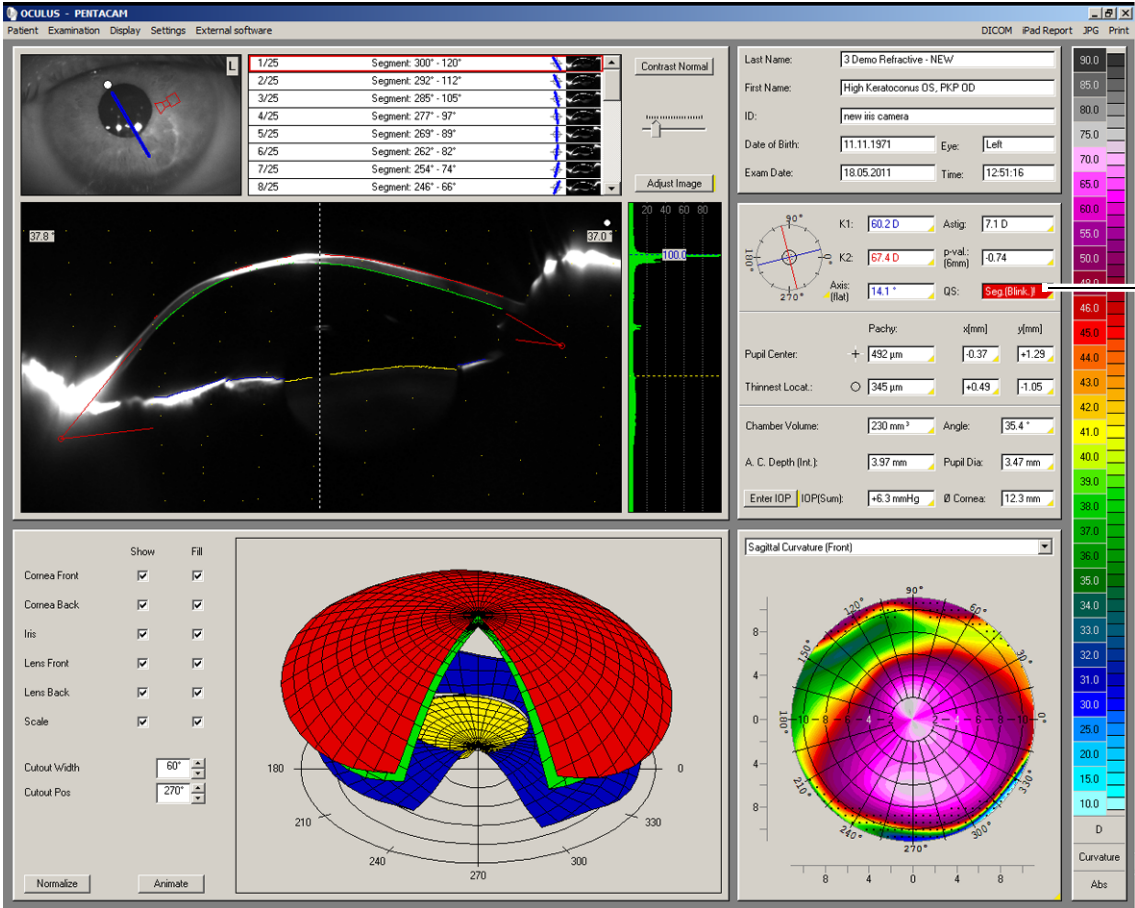

1 "QS" display

Fig. 11-15: Pentacam® program with "QS" display



Note

All examinations are automatically saved, regardless of the quality of the measurement taken.

If the "QS" display

- reads OK, the measurement is correct and can be reproduced.
- is red, you must repeat the measurement.
- ➔ is highlighted in yellow, click on the "QS" button.

The following dialog box appears:

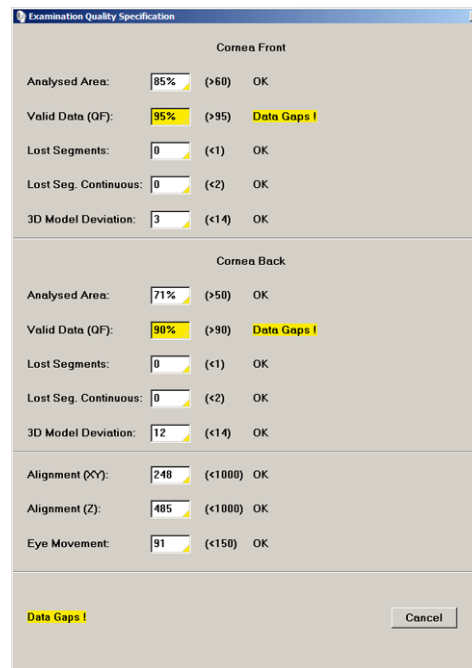

Fig. 11-16: Examination Quality Specification

- ➔ Check the measurement results.
- ➔ If you have any doubts, repeat the measurement.

Notes on individual parameters

- **Analysed Area**
If this value is less than the permissible threshold, the patient must widen his or her eye.
- **Valid Data**
If this value is less than the permissible threshold, you must darken the room.
- **Lost Segments and Lost Seg. Continuous**
If one of these values exceeds the permissible threshold, you must ask the patient not to blink while you are measuring.
- **3D Model Deviation:** deviation of measured cornea from calculated 3D model
- **Alignment (XY) and Alignment (Z)**
If one of these values exceeds the permissible threshold, you may have moved the cross slide at the moment you began measuring.
- **Eye Movement**
If this value exceeds the permissible threshold, the fixation of the patient is inadequate.

- SNR
Signal to noise ratio

Terminating "QS"

- ➔ Click [Cancel] to return to the Pentacam® program.
- ➔ If required, delete the measurement if the image is inadequate.
- ➔ Terminate the current examination which has been saved.
- ➔ If required, make preparations to examine another patient. In the "Pentacam" overview, select the "Examination" menu and click [New Patient/End].

12 Managing Patient Data

Once you have completed an examination, you can do the following with the patient data:

- Rename it, [sec. 12.1, page 52](#)
- Export it, [sec. 12.2, page 52](#)
- Import it, [sec. 12.3, page 54](#)
- Back up, [sec. 12.4, page 55](#)



For more information on Patient Data Management, refer to the [User Guide](#).

12.1 Rename Patient Data

After creating of the patient data, you can edit it.

- ➔ Press the [Change] button.
The input boxes for patient data are now enabled, and the cursor jumps to the "Last name" field.
- ➔ Change the entries in the individual boxes.
- ➔ Press the [Save] button.

12.2 Exporting Patient Data

Patient and examination data can be exported, for example, for forwarding to another clinic.

- ➔ Select the patient and also one of the examinations in the respective list as required.
- ➔ Click [Export] button below the patient list. The following dialog appears:

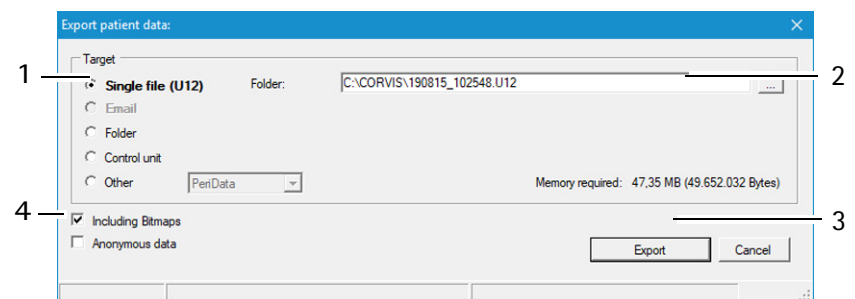

- | | |
|--------------------------------|---------------------------------|
| 1 Saving destination selection | 3 [Cancel] and [Export] buttons |
| 2 [...] button | 4 Options for data export |

Fig. 12-1: "Export patient data" dialog



The default options for import and export of data are configured in the "Settings" field, see also the [User Guide](#).

Depending on the settings, you may not have to perform all of the following steps (e.g. selection of the directory).

- ➔ Select the "Target" (1) where you would like to export the data.



Recommendation: Export the patient data using the "Single file (U12)" option.

- ➔ Press the [...] button. (2).
- ➔ In the dialog that appears, select the folder or the file to which the patient data should be exported.
- ➔ Confirm your selection with [OK] or [Save].
- ➔ Select whether the data with or without camera images and possibly to be exported anonymously.
- ➔ Click [Export] to export the data.

The patient and examination data have now been saved at the destination specified.

You can send data stored on the hard drive as an e-mail attachment.



Note

Requirements for transferring data to another PC:

- The Pentacam® AXL program must be installed on the other PC. If the program is updated on the Pentacam® AXL PC (sender), the program on the other PC (recipient) must also be updated.
- Make sure, that the PC is connected to a local network controlled by the Floating License Key or that a single license key is connected to the PC in order to interactively evaluate the exams.

12.3 Importing Patient Data

Import received patient and examination data in the Pentacam® AXL software. In case you keep patient data on a USB stick, you can import this data.



Note

Risk of loss of data due to computer viruses
 Computer viruses can cause loss of data.

➔ Run a virus check before importing data from the USB flash drive.

➔ Press the [Import] button. The following dialog appears:

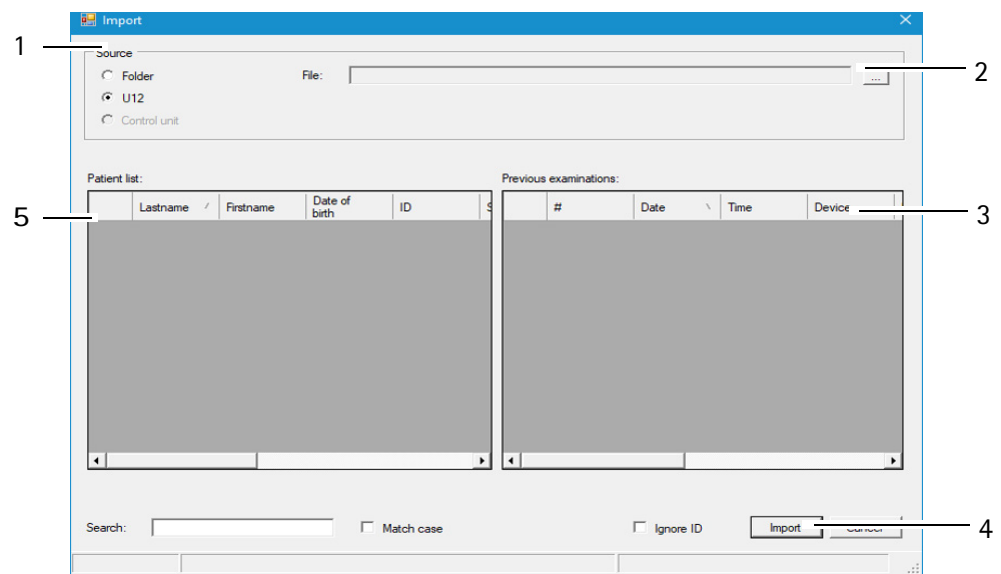

- 1 Select data source
- 2 [...] button
- 3 Previous examinations
- 4 [Import] button
- 5 Patient list

Fig. 12-2: "Import" dialog



The default options for import and export of data are configured in the "Settings" field, see also the [User Guide](#).

➔ Depending on the settings, you may not have to perform all of the following steps (e.g. selection of the directory).

➔ Select the option (1) where the source data are contained ("Folder" or "U12" (single file)).



Recommendation: Import the patient data using the "Single file (U12)" option.

- ➔ Press the [...] button. (2).
- ➔ In the dialog box, select the directory or the file where the patient data are located.
- ➔ Confirm your selection with [OK] or [Open].
The patients and the associated examinations that are found are displayed in the lower part of the dialog.
- ➔ To import the data, press the [Import] button (4).
The data will then be available in the Patient Data Management system.

12.4 Data Backup

You should make a backup copy of patient and examination data at regular intervals. In case of loss of data, you can reconstruct the data from a previously created backup with the help of this function. Since data backup takes several minutes, depending on the scope of the database and the data to be backed up, a backup should be carried out when the PC and the device will not be needed.



Note

Risk of loss of data due to computer viruses

Computer viruses can cause loss of data.

- ➔ Run a virus check before making a backup to a USB flash drive.



The general rules for security backups apply to the creation of backup copies created with the help of the Patient Data Management system. Storage of backup files should always be done on a separate system (for example on the delivered external hard drive on a USB flash drive with adequate capacity).

12.4.1 Backup Data

- ➔ Press the [Backup] button at the top right of the Patient Data Management system. The following dialog is displayed:

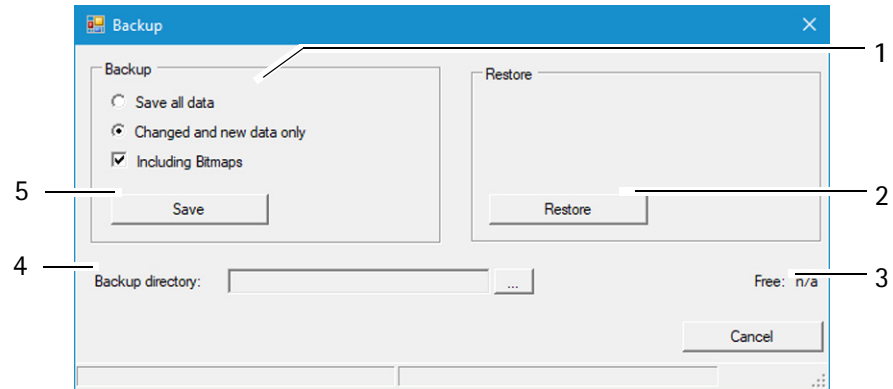

- | | |
|------------------------------|-------------------------------------|
| 1 Backup data selection | 4 Backup directory and button [...] |
| 2 [Restore] button | 5 [Save] button |
| 3 Display free storage space | |
- Fig. 12-3: "Backup" dialog

- ➔ Select whether all of the data or only changed data should be backed up.



The Patient Data Management system internally tags all saved data records.

If you select the option "Changed and new data only", only the data records that were not saved during a previous backup will be backed up.

- ➔ Press the [...] button to the right of the "Backup directory" box (4).
- ➔ In the dialog that appears, select the folder to which the data should be backed up.
- ➔ Confirm your selection with [OK].
- ➔ To back up the data, press the [Save] button (5). The previously selected data will then be backed up to the corresponding folder.

12.4.2 Reconstructing Data

If a loss of data occurs, the data from a previous backup can be re-imported into the Patient Data Management system.

- ➔ Press the [...] button.
- ➔ In the dialog that appears, select the folder which contains the backup data.
- ➔ Confirm your selection with [OK].
- ➔ To import the data, press the [Restore] button (2). All data in the appropriate directory are copied to the Patient Data Management system.

12.4.3 Automatic Backup

In addition to the manually performed backup, it is also possible to automatically run a backup when exiting the Patient Data Management system. The settings required for this can be made in the "Settings" area, see [User Guide](#).

13 Test measurement with the Pentacam® AXL

13.1 Test measurement: Tomography (3D scan)

The Pentacam® AXL is tested and calibrated at OCULUS.

OCULUS Optikgeräte GmbH recommends to carry out additional regular test measurements with the Pentacam® AXL.

Start the test with a measurement of a human eye.

Carry out at least five successive measurements on each eye. Calculate the arithmetic mean and log the results.

Once a month, this measurement sequence should be carried out on the same eye as described above.

Compare the arithmetic mean from the initial measurement with the current measurement.

The following table depicts the tolerance range between the result of the initial measurement and the result of the current measurement:

	Tolerance range
Curvature	+/- 0,1 dpt
Pachymetry	+/- 10 µm

If the difference between the initial value and the current value lies outside the tolerance range, please contact our service or your marketing authorisation holder. The values are shown in the overview display, for example; please refer to the [user manual](#).

13.2 Test measurement: Axial length

13.2.1 Attach the test eye

Tool and material

- Test eye (70108)
- 1.5 mm Allen key

Procedure

- ➔ Turn off the Pentacam® AXL.

- Use the Allen key to attach the test eye to the chin and head rest, directly underneath the retainer for the head rest.



Fig. 13-1: Attach the test eye

- Make sure that the test eye is in park/home position when it is not being used.



Fig. 13-2: Test eye in park/home position

13.2.2 Carrying out the test measurement

The axial length test measurement routine has to be performed daily before the first "Full Sequence Examination". After the Full Sequence Mode is selected the following screen appears:

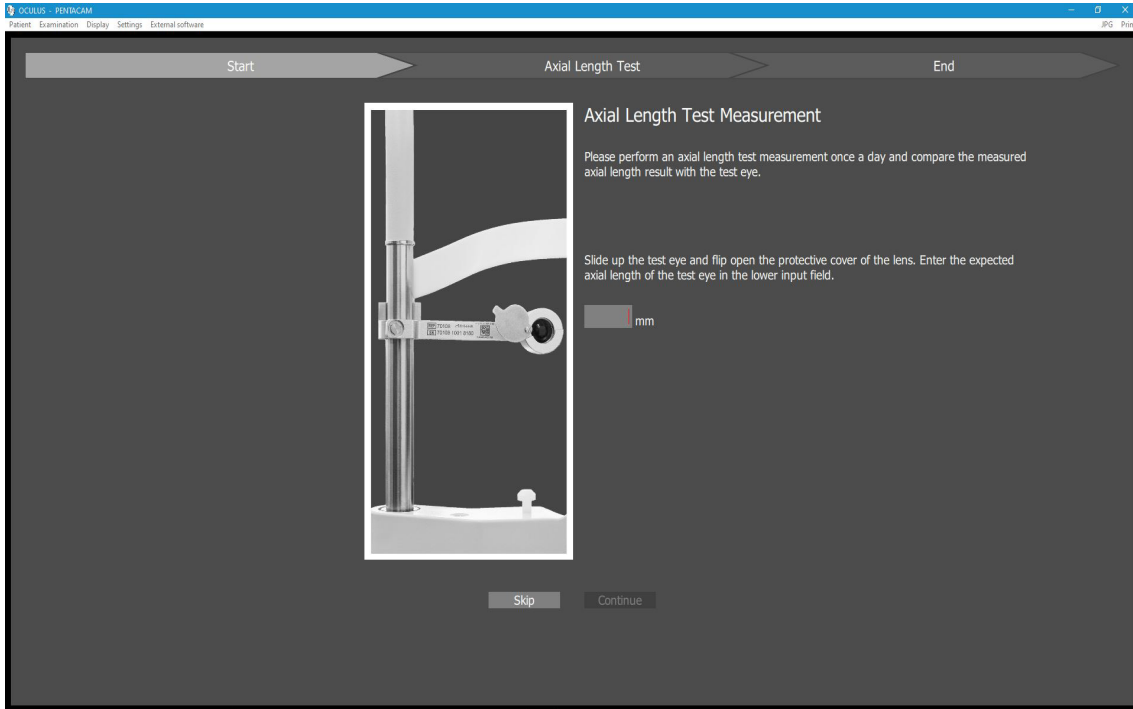

Follow the instructions on the screen, type in the axial length of the test eye and click on "Continue". For the case the test measurement is skipped it is saved in the software and all following AXL scans receive a bad QS value including the message "Missing test measurement".



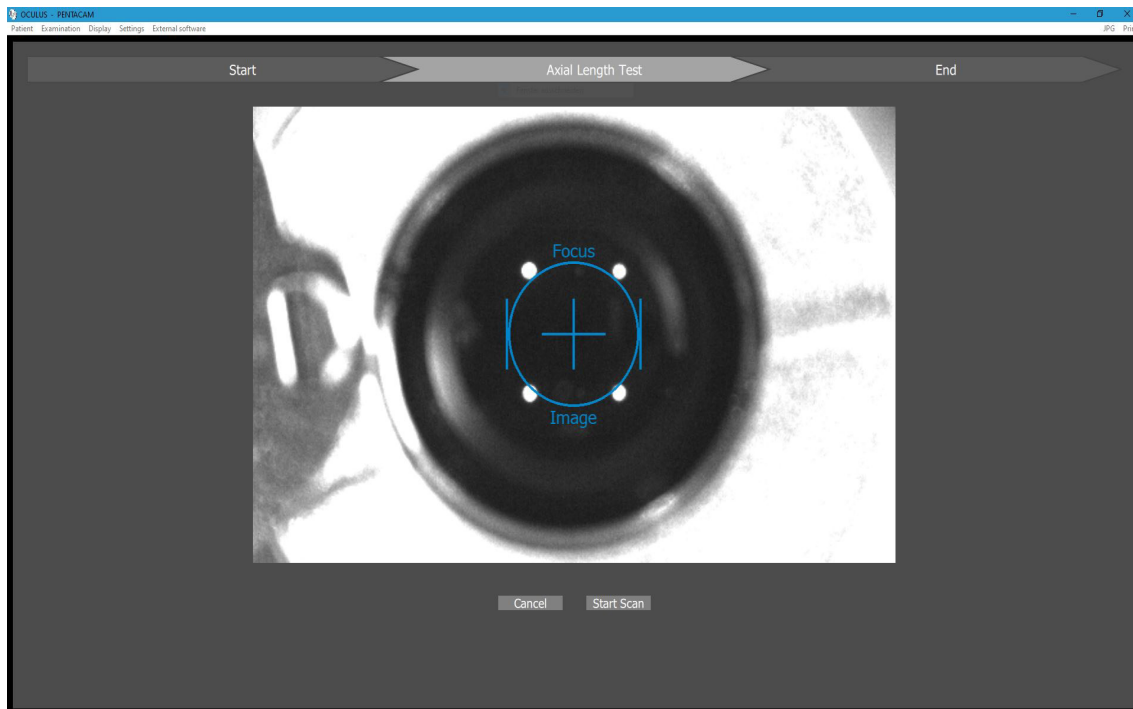

Align the Pentacam® AXL to the test eye, "Fine adjustment" [page 44](#).

- Press [Start Scan] or press the return button to start the test measurement manually.

In case the test measurement is ok the following message appears:

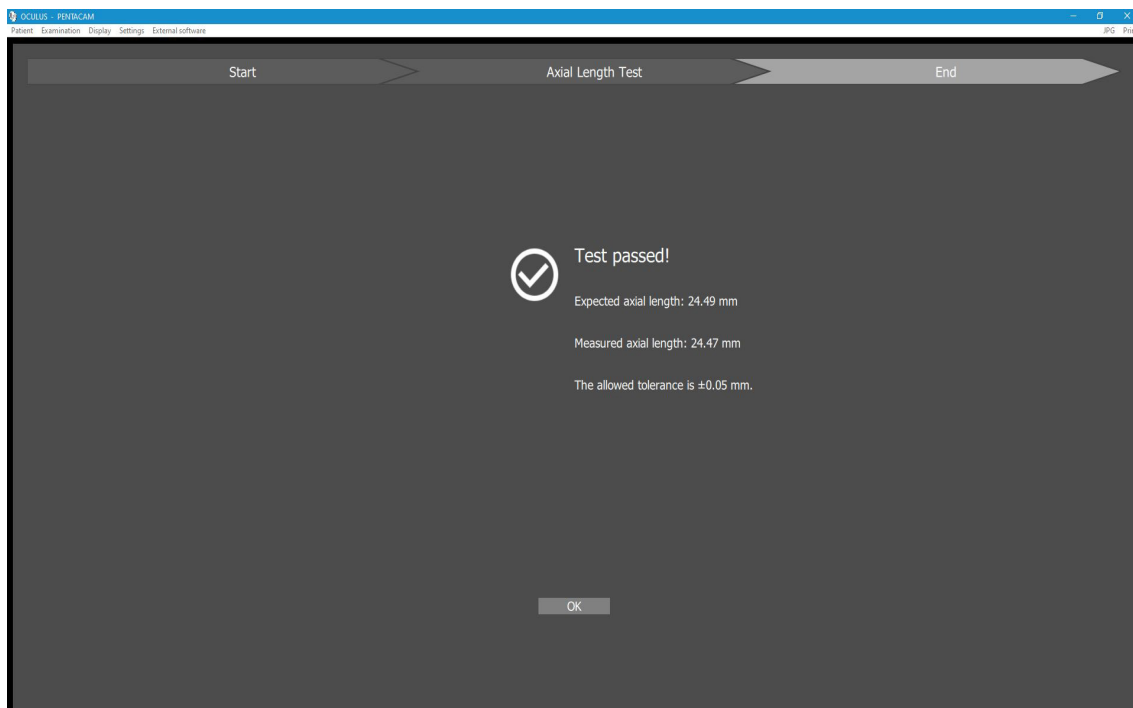

To finish the process click "OK".

In case the test measurement failed the following message appears:

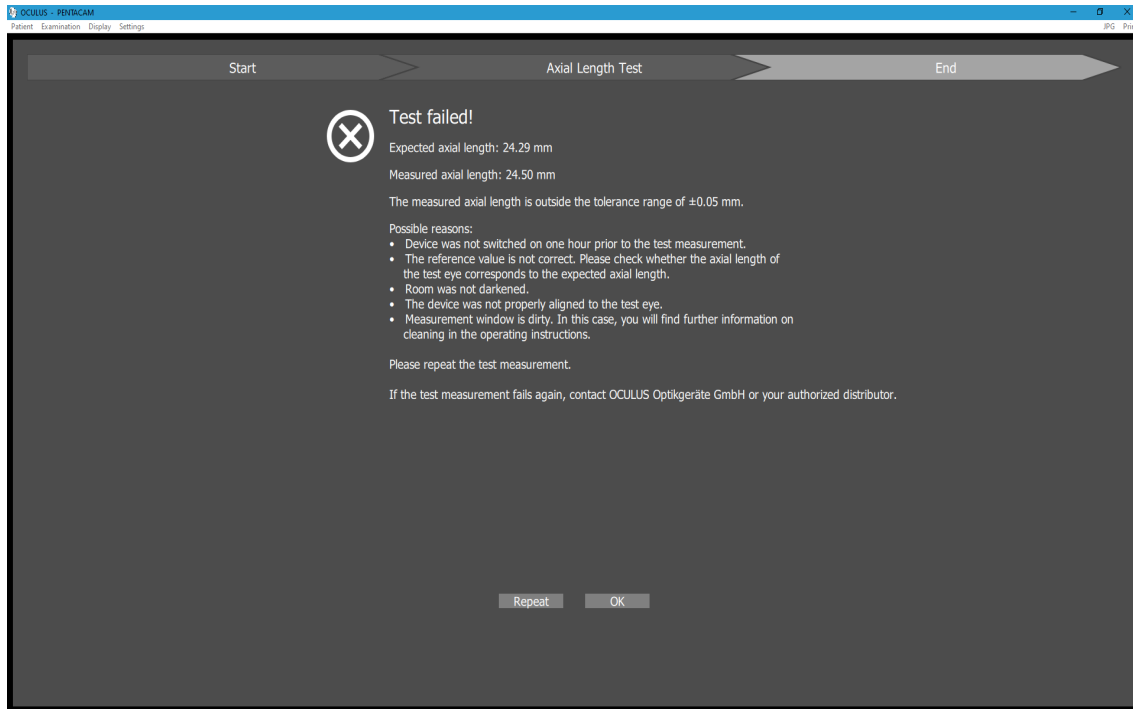

- ➔ Exclude all possible reasons (see screen) for a fail test measurement.
- ➔ Repeat the test measurement again. If also this test measurement is not successful please call your authorized dealer.
- ➔ To finish this process click "OK".



In case you had to replace the test eye because of any reason you have to type in the axial length of the new test eye into the input field before you do a new test measurement.

After the test measurement process is finished you can slide down the test eye.

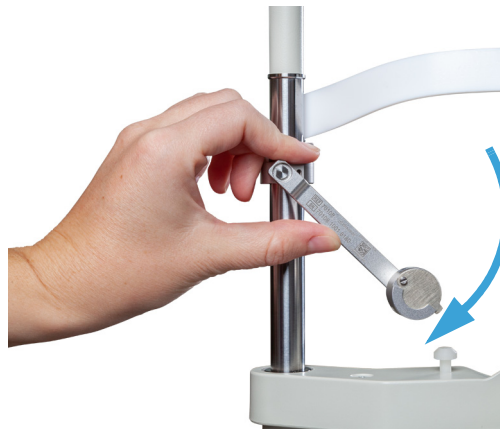

Fig. 13-3: Sliding down the test eye

The protective cover closes automatically. You can proceed with the measurements.



During an examination: If you adjust the chin rest for a smaller head (the head of a child, for example), the test eye may be in the way. Slide the test eye to the side and then adjust the chin rest.

14 Cleaning, Disinfection and Maintenance

Cleaning and disinfection of the Pentacam® AXL is described in this chapter. Sterilization is not required.

- Heed the product descriptions and instruction manuals of products and equipment you use to care for, clean, and disinfect the unit and/or its accessories.
- Do not clean the Pentacam® AXL with aggressive, chlorine containing, abrasive or sharp cleaning agents.



Clean the cover glass from time to time to retain the high measurement accuracy of the Pentacam® AXL and to avoid malfunctions. If the test measurement shows a peak at 39 mm, a corresponding message will occur, see [sec. 13, page 57](#).

14.1 Cleaning



Attention

Risk of electric shock if the Pentacam® AXL is not completely disconnected from the mains for the cleaning.

- Turn the Pentacam® AXL off, [sec. 7.3, page 20](#).
- Pull the power plug before cleaning. When disconnecting electrical connections, pull on the respective plug and not on the cable itself.

Required materials:

- Antistatic cleaning agent
- Cleaner for painted surfaces: Mixture of equal parts of alcohol and distilled water, possibly with a few drops of household detergent
- Soft, lint-free cloth
- Purified compressed air
- commercial clean agent for the acrylic glass

Cleaning intervals

- Clean the components of the Pentacam® AXL once a month or if necessary.

Cleaning the Housing

- It is best to clean the housing surfaces with a soft cloth and an anti-static cleaning agent.
- Wipe off any residue from painted surfaces with the mixture for painted surfaces.

Cleaning the Chin-Forehead Rest

- Make sure that no liquid gets into any of the openings of the Pentacam® AXL.
Do not use liquid from aerosol cans.
- Clean the chin-forehead rest with a soap solution (or with alcohol, if very dirty).
- Use a lint-free, damp cloth.

Cleaning the illuminated slit

The optical components illuminating the slit, and the lens in front of the camera are precision parts and sensitive to pressure. The surfaces of these components are susceptible to scratching.



Attention

When cleaning the illuminated slit, do not use a cloth or other cleaning agents.

-
- Carefully clean the centre of the illuminated slit with purified compressed air.
 - Clean the lens in front of the camera using a dry, lint-free cloth.
 - Clean the acrylic glass with a commercial clean agent.

14.2 Disinfection

- Recommendation: Use disinfection wipes suitable for medical devices, for example:

Mikrozid sensitive wipes premium; Fa. Schülke & Mayr

Softpack 48 Stück / Art. Nr. 165711

Schülke & Mayr GmbH; Tel: +4940521000 / Fax: +494052100318

E-Mail@schuelke.com; www.schuelke.com



Note

Equipment damage caused by disinfectant solution

The disinfectant solution may damage the surface of the device if it is sprayed directly on it.

- Spray the disinfectant solution onto a cleaning cloth, do not spray it directly on the device.

-
- Disinfect the forehead rest after each examination.
 - If you do not use paper for the chinrest, disinfect the chinrest after each examination.

14.3 Maintenance

In order to retain the high measurement accuracy of the Pentacam® AXL OCULUS Optikgeräte GmbH recommends to perform a maintenance service every two years or after 25000 scans. A corresponding message appears.

By daily pop up window:

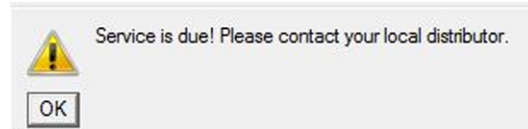

Fig. 14-1: Daily pop up window

In the settings, [see User Guide](#):



Fig. 14-2: Date of next service and number of performed examinations

In the scan menu, [sec. 10, page 27](#):

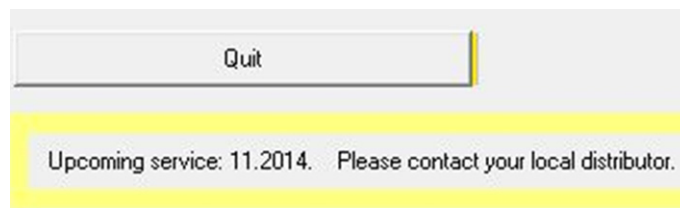

Fig. 14-3: Preliminary information (3 month before)

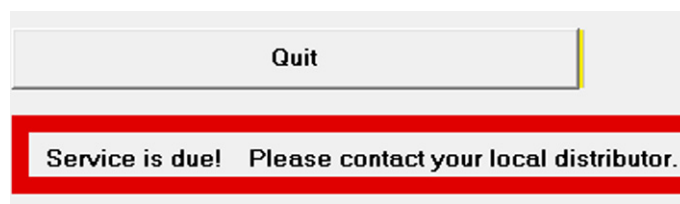

Fig. 14-4: Information when service is due

In examinations (it will be stored):



Fig. 14-5: Sign to perform maintenance

Let the Pentacam® AXL checked by our service department or an authorized distributor.



Attention

Risk of personal injury or material damage due to invisible laser radiation
The Pentacam® AXL contains a Class 1 laser according to IEC 60825-1: 2014. It is an encapsulated laser system. When the Pentacam® AXL cover is opened, you may be exposed to invisible, Class 3R (5 mW) laser radiation.

- ➔ Never open the unit.
- ➔ For authorized service personnel only: When doing maintenance jobs, avoid looking directly into the laser beam.

14.4 Attaching Paper to the Chin Rest

If you want to attach new chin rest paper, follow these instructions:

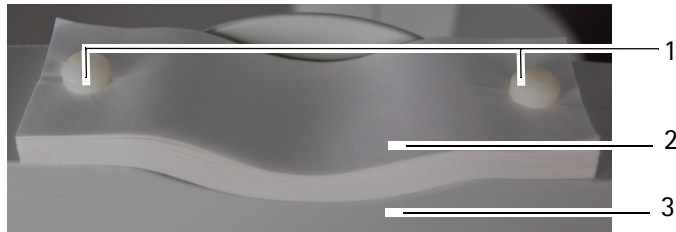

1 Pins

2 Paper for chin support

3 Chin rest

Fig. 14-6: Fasten chin rest paper

- ➔ Pull the two pins (1) out of the chin rest.
- ➔ Place the chin rest paper (2) in such a way that the holes of the paper and those in the chin rest (3) are aligned.
- ➔ Insert the two pins (1) in the chin rest.

15 Troubleshooting



Attention

If an error occurs which you are unable to correct by following the instructions below, label the device as "out of order" and contact our service department or an authorised distributor.

Error	Possible cause	Remedy
After you have started the Pentacam® AXL program (sec. 9, page 25), the following dialog box appears: "No communication with Pentacam!"..	No power to the power adapter	Check whether the indicator light on the power supply is on. If not, connect the power supply to the mains.
	Connection cable of the Pentacam® AXL is not plugged properly.	Check whether <ul style="list-style-type: none"> ■ the power supply cable is correctly attached to the Pentacam® AXL. ■ the blue slit light is visible in the Scan menu (sec. 10, page 27). ■ the USB connector is properly inserted
	Software/hardware problems	Switch the Pentacam® AXL off and restart the PC. Switch the Pentacam® AXL on as soon as Patient Data Management becomes active. When you start the Pentacam® AXL program, the message, "Load Bootloader" must appear. Contact the service department or your authorised distributor.

16 Transport and Storage

The Pentacam® AXL, must be properly dismantled and packed before being transported or stored.

16.1 Information on Transport and Storage

Storage

Ambient temperature range	-10°C to +55°C
Relative humidity, including condensation	10% to 95%
Air pressure range	700 hPa to 1060 hPa

Transport:

Ambient temperature range	-40°C to +70°C
Relative humidity range from	10% to 95%, including condensation
Air pressure range	500 hPa to 1060 hPa

16.2 Disassembly

- ➔ End the current session.
- ➔ Switch off the device.
- ➔ Disconnect the cable from the computer/laptop and the power adapter.



Abb. 16-1: Disassembly

- ➔ Loosen the screw connection of the Y cable and pull it out. When disconnecting electrical connections, pull on the respective plug and not on the cable itself.

16.3 Transport and Storage



Attention

Risk of equipment damage due to incorrect shipment or from improper storage

- ➔ Avoid shocks, vibrations, and contamination.
 - ➔ Avoid high temperatures and humidity.
-
- ➔ Transport the Pentacam® AXL carefully.
 - ➔ Do not hold the device by the joystick to carry it.
 - ➔ Store the Pentacam® AXL in compliance with the storage conditions.
 - ➔ Avoid placing near heaters and moisture.

17 Disposal

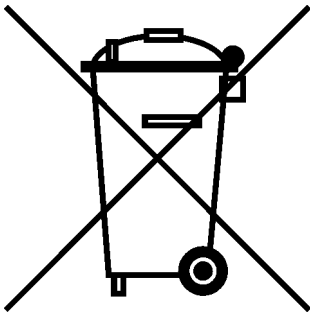

In accordance with Directive 2012/19/EC of the European Parliament and the Council of 4th of July 2012, and in accordance with German law governing the marketing, return and environmentally compatible disposal of used electrical and electronic devices, such appliances must be recycled and may not be discarded as household waste.

➔ Dispose the Pentacam® AXL in a compliant manner.

18 Terms of Warranty and Servicing

18.1 Terms of Warranty

Please note the following warranty provisions:

- Prior to and while operating the device it is important that you heed the instruction manual and safety instructions.
- In accordance with legal regulations, you are entitled to a warranty for the Pentacam® AXL.
- If modifications are made to the Pentacam® AXL by unauthorized persons, all warranty claims shall be voided. Improper modifications and repairs may result in considerable hazards to users and patients.
- Any entitlement to a warranty shall also be void if unauthorized persons interfere with the supplied computer hardware and software.
- Any transport damage must be reported immediately to the shipping company. Have the transport damage noted on the bill of lading so that complaint handling and compensation of damages can proceed in an orderly manner.
- In general, our Business and Shipping Terms on the date of purchase apply.

18.2 Assumption of Liability for Functions and Damage

OCULUS will only accept responsibility for the safety, reliability and serviceability of the Pentacam® AXL if the unit is used in compliance with the following terms:

- Only use the equipment in conformance with this instruction manual.
- There are no parts either on or inside the Pentacam® AXL that require maintenance or repair by the user. If assembly work, modifications, adjustments, repairs, changes or service are performed by unauthorized personnel, or if the Pentacam® AXL is improperly maintained or handled, then any liability by OCULUS is voided.
- If the above-referenced work is performed by authorized persons, request a certification of the scope and type of repair, and, if necessary, the changes to the standard values or to the operating range from the service technician. This certification must contain the date of performance and statement of the performing firm, with signature.
- If requested, OCULUS will provide the service technician with a list of spare parts and additional descriptive material for this purpose.
- Make certain that only original OCULUS parts are used.

18.3 Manufacturer and Service Address

Supplemental information is available from our Service Department or from our authorized representatives.

Manufacturer and Service address:

OCULUS Optikgeräte GmbH
Münchholzhäuser Straße 29
35582 Wetzlar
GERMANY
Tel.: +49 641 2005-0
Fax: +49 641 2005-295
E-mail: export@oculus.de
www.oculus.de



USA:

OCULUS, Inc.
17721 59th Avenue NE
Arlington
WA 98223
Tel. +1 425 670 9977
Fax +1 425 670 0742
E-mail: sales@oculususa.com
<http://www.oculususa.com>



19 Technical Data

Measuring equipment

Camera	Digital CCD camera
Light source	Blue LEDs (475 nm, UV-free)
Speed	100 images in 2 seconds, 2760 measuring points per recorded image
Number of evaluated measuring points	max. 138,000
Dimensions W x D x H (measuring head)	275 x 320 to 400 x 500 to 530 mm (10.8 x 12.6 to 15.7 x 19.7 to 20.9 in)
Weight Pentacam® AXL (measuring head)	8.4 kg (18.5 lbs)

Measuring range

Corneal topographer according ISO 19980	Type A
Curvature:	3 to 38 mm 9 to 99 D
Accuracy	± 0.1 D
Reproducibility	± 0.1 D
Working distance	80 mm
Axial length Reproducibility	14 to 40 mm ± 30µm

Power adapter

Power adapter	HEMG 49 (05150150)
Mains connection	90 - 264 V AC
Frequency	47 - 63 Hz
Power input, max.	85 VA
Output voltage	24 V DC
Fuses	Integrated overcurrent shut-off

Power supply Pentacam® AXL

Output voltage	24 V DC
Max. power consumption	42 W

Other information

Contraindications	None noted
Lifecycle expectancy	Up to 10 years

Classification according to IEC 60601 - 1

Type of protection against electrical shock: protection class	2
Level of protection against electrical shock: type	B
Level of protection against damaging water entry	IP20

Ambient operating requirements

Temperature	+10 °C to +35 °C
Humidity	30% to 90%
Air pressure	800hPa to 1060hPa

Storage conditions

Ambient temperature range	-10°C to +55°C
Relative humidity, including condensation	10% to 95%
Air pressure range	700 hPa bis 1060 hPa

Transport conditions

Ambient temperature range	-40°C to +70°C
Relative humidity, including condensation	10% to 95%
Air pressure range	500 hPa to 1060 hPa

Computer

Use a computer which is in conformity with the DIN EN 60950 or IEC 62368 standard.

Recommended computer specifications	Intel® Core™ i5, 500 GB HDD, 8 GB RAM, Windows® 10, Intel® HD Graphics
-------------------------------------	------------------------------------------------------------------------

CE in accordance with Regulation (EU) 2017/745 on Medical Devices (MDR)

The unit is a Class IIa product.



Conformity assessment procedure: (EU) 2017/745 MDR, Annex IX excluding chapter II.

Classification according to IEC 60825-1: 2014

The unit contains a Class 1 laser.

Maximum output of the laser radiation	0.7 mW
Single pulse duration	520 ms
Pulse count per examination	6x
Wavelength	880 nm

20 Annex

20.1 Electromagnetic Compatibility

Medical electrical equipment is subject to special preary requirements with respect to EMC, and must be installed and operated according to the EMC-Instructions contained in the accompanying paperwork.

No special measures need be observed in respect of OCULUS devices and systems.

Portable and mobile RF-communications devices can interfere with electrically operated medical devices.

The device is intended to be used in a professional health care facility environment.

Manufactured under consideration of permitted degradations during or as a consequence of the EMC test without affecting the basic safety:

- A short interruption of the USB connection during the examination is permissible because it will not affect the diagnosis, treatment and observation.



Attention

The use of accessories, transducers and cables not specified by OCULUS (for example as replacement parts) may result in increased emissions or decreased immunity of the Pentacam® AXL.

- ➔ Use only the original accessories, transducers and cables specified by OCULUS.

The use of accessories, transducers and cables specified by OCULUS with devices other than the Pentacam® AXL may result in increased emissions or decreased immunity of the other device.

- ➔ Do not use the accessories, transducers and cables specified by OCULUS with devices other than the Pentacam® AXL.

To be in compliance with the requirements of the IEC 60601-1-2. 6.1 and 6.2 the following types of equipment, accessories, power adapters and cables must be used.

Order number	Description	
70100	Pentacam® AXL	
05200320	Cable with connector plug, EU standard	2.5 m (98.4 in)
05200210 (110 Volt)	Cable with connector plug, US standard	2.5 m (98.4 in)
05150150	Power adapter HMEG 49	24 V, 2,1A
70002	Y cable with galvanic isolation	2 m

20.2 Guidance and Manufacturer’s Declaration - Electromagnetic Emissions for the Pentacam® AXL

Guidance and manufacturer’s declaration electromagnetic emissions IEC 60601-1-2, 5.2.2.1, table 1

The OCULUS Pentacam® AXL is intended for operation in the electromagnetic environment specified below. The user of the Pentacam® AXL should ensure that it is being used in such an environment.

Emissions test	Compliance	Electromagnetic environment – guidance
RF emissions CISPR 11	Group 1	The Pentacam® AXL uses RF energy only for its internal function. Therefore, its RF emissions are very low and are not likely to cause any interference in nearby electronic equipment.
HF-emissions CISPR 11	Class B	
Harmonics emissions IEC 61000-3-2	Class A	
Voltage fluctuations / flicker emissions IEC 61000-3-3	complies	

Guidance and manufacturer's declaration electromagnetic immunity, IEC 60601-1-2, 5.2.2.1, table 2

Immunity test	IEC 60601 test level	Compliance level	Electromagnetic environment – guidelines
Electrostatic discharge (ESD) IEC 61000-4-2	± 6 kV contact ± 8 kV air	± 6 kV contact ± 8 kV air	Floors should be made of wood or concrete or covered with ceramic tiles. If the floor is covered with synthetic material, the relative humidity must be at least 30%.
Electrical Fast transient/bursts IEC 61000-4-4	± 2 kV for power supply lines ± 1 kV for input/output lines	± 2 kV for power supply lines ± 1 kV for input/output lines	Mains power quality should be that of a typical commercial or hospital environment.
Surge IEC 6100-4-5	± 1 kV line(s) to line(s) ± 2 kV line(s) to earth	± 1 kV differential mode ± 2 kV line(s) to earth	Mains power quality should be that of a typical commercial or hospital environment.
Voltage dips, short interruptions, and voltage variations on power supply input lines IEC 61000-4-11	< 5% U_{τ} (> 95% dip in U_{τ}) for 0,5 cycle	< 5% U_{τ} (> 95% dip in U_{τ}) for 0,5 cycle	Mains power quality should be that of a typical commercial or hospital environment. If the user of the Pentacam® AXL requires continued operation during power mains interruptions, it is recommended that the Pentacam® AXL be powered from an uninterruptible power supply or battery.
	40 % U_{τ} (60% dip in U_{τ}) for 5 cycles	40 % U_{τ} (60% dip in U_{τ}) for 5 cycles	
	70% U_{τ} (30% dip in U_{τ}) for 25 cycles	70% U_{τ} (30% dip in U_{τ}) for 25 cycles	
	<5% U_{τ} (> 95% dip in U_{τ}) for 5 s	<5% U_{τ} (> 95% dip in U_{τ}) for 5 sec	
Power frequency (50/60Hz) magnetic field IEC 61000-4-8	3 A/m	3 A/m	Power frequency magnetic fields should be at levels characteristic of a typical location in a typical commercial or hospital environment.

Note: U_{τ} is the a.c. mains voltage prior to application of the test level.

Guidance and manufacturer’s declaration electromagnetic immunity, IEC 60601-1-2, 5.2.2.2, table 4

Immunity test	IEC 60601 test level	Compliance level	Electromagnetic environment – Guidelines
Conducted RF IEC 61000-4-6	3 Vrms 150 KHz to 80 Mhz	$V_{rms} = 3\text{ V}$	<p>Portable and mobile RF communications equipment should be used no closer to any part of Pentacam® AXL, including cables, than the recommended separation distance calculated from the equation applicable to the frequency of the transmitter.</p> <p>Recommended separation distance</p> $d = \left[\frac{3,5}{(V_1)} \right] \sqrt{P}$
Radiated RF IEC 61000-4-3	3 V/m 80 MHz to 2.5 GHz	$E = 3\text{ V/m}$	$d = \left[\frac{3,5}{(E_1)} \right] \sqrt{P} \quad 80\text{MHz to } 800\text{ MHz}$ $d = \left[\frac{7}{(E_1)} \right] \sqrt{P} \quad 800\text{ MHz to } 2.5\text{ GHz}$ <p>where P is the maximum output power rating of the transmitter in watts (W) according to the transmitter manufacturer and d is the recommended separation distance in metres (m).</p> <p>Field strength from fixed RF transmitters, as determined by an electromagnetic site survey (a), should be less than the compliance level in each frequency range (b).</p> <p>Interferences may occur in the vicinity of equipment marked with the following symbol:</p> 
Note 1:	At 80 Hz and 800 MHz, the higher frequency range applies.		
Note 2:	These guidelines may not apply in all situations. Electromagnetic propagation is affected by absorption and reflection from structures, objects and people.		
<p>a. Field strengths from fixed transmitters, such as base stations for radio (cellular/cordless) telephones and land mobile radios, amateur radios, AM and FM radio broadcast, and TV broadcast cannot be predicted theoretically with accuracy. To assess the electromagnetic environment due to fixed RF transmitters, and electromagnetic site survey should be considered. If the measured field strength in the location in which the Pentacam® AXL is used exceeds the applicable RF compliance level above, the Pentacam® AXL should be observed to verify normal operation. If abnormal performance is observed, additional measures may be necessary, such as re-orienting or relocating the Pentacam® AXL.</p> <p>b. Over the frequency range 150 KHz to 80 MHz, field strengths should be less than 3 V/m.</p>			

Recommended separation distances between portable and mobile RF communications equipment and the Pentacam® AXL, IEC 60601-1-2, 5.2.2.2, table 6

The Pentacam® AXL is intended for use in an electromagnetic environment in which radiated RF disturbances are controlled. The customer or the user of the Pentacam® AXL can help prevent electromagnetic interference by maintaining a minimum distance between portable and mobile RF communications equipment (transmitters) and the Pentacam® AXL as recommended below, according to the maximum output power of the communications equipment.

Rated maximum output power of transmitter W	Separation distance according to frequency of transmitter m		
	150 KHz to 80 Mhz $d = 1.2 \sqrt{P}$	80 MHz to 800 MHz $d = 1.2 \sqrt{P}$	800 MHz to 2.5 GHz $d = 2.3 \sqrt{P}$
0.01	0.12	0.12	0.23
0.1	0.38	0.38	0.73
1	1.2	1.2	2.3
10	3.80	3.80	7.3
100	12	12	23

For transmitters rated at a maximum output power not listed above, the recommended separation distance d in metres (m) can be estimated using the equation applicable to the frequency of the transmitter, where P is the maximum output power rating of the transmitter in watts (W) according to the transmitter manufacturer.

NOTE 1: At 80 MHz and 800 MHz, the separation distance for the higher frequency range applies.

NOTE 2: These guidelines may not apply in all situations. Electromagnetic propagation is affected by absorption and reflection from structures, objects and people.

20.3 Description of the Connection

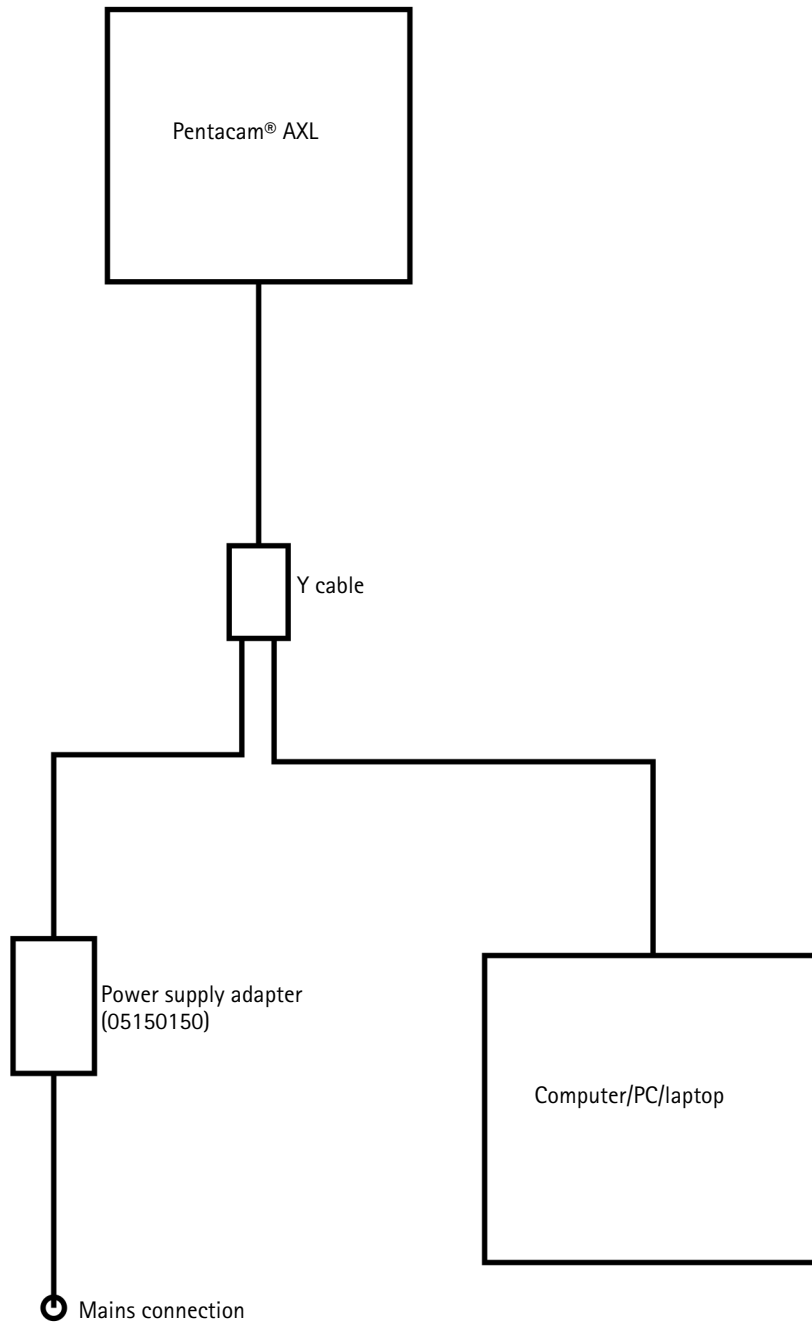

20.4 Data Sheet HEMG 49-S240210-7 [05150150]

HiTRON

UNIVERSAL INPUT AC-DC MEDICAL & ITE APPLICATION EXTERNAL DESKTOP SWITCHING ADAPTER 48-50 WATTS GREEN POWER SINGLE OUTPUT HEMG49 SERIES



FEATURES:

- ACCOMMODATE UNIVERSAL AC INPUT
- MEET MEDICAL STANDARDS IEC60601-1 & ITE STANDARDS IEC60950-1
- EMI MEET EN 55011 & EN55022 / FCC CLASS B
- MEET ENERGY STAR LEVEL V & CEC LEVEL IV
- CE MARKING COMPLIANCE

SPECIFICATION

INPUT SPECIFICATION

Input Voltage: Typical 90-264Vac.
Input Connector: 3 pole AC inlet IEC320-C14(DT7) / 2 pole AC inlet IEC320-C8(DT8).
Input Frequency: 47-63Hz.
Inrush Current: 12Arms (52Apk) at 230Vac.
Input Current: Typical 0.91A at 115Vac/ 0.57A at 230Vac.
Dielectric Withstand: Meet IEC60601-1 & IEC60950-1.
EMI: Meet EN55011 & EN55022 / FCC Class B.
Hold-up Time: Typical 12mS at 115Vac. Typical 70mS at 230Vac.
Over Temp. Protection: Optional (NTC circuit).
Earth Leakage Current (Class I) : Less than 0.3 mA.
Touch Leakage Current (Class I & II) :Less than 0.1mA.
No Load Power: Less than 0.3W at 230Vac

OUTPUT SPECIFICATION

Output Voltage: See Ratings Chart.
Output Current: See Ratings Chart.
Output Wattage: Typical 48-50Watts.
Output Connector & Cord: Optional.
Line Regulation: Typical 0.1%.
Load Regulation: Typical $\pm 1.5-3.0\%$.
Noise & Ripple: 1.0% peak to peak.
OVP: Built-in by latch circuit.
Adjustability: Factory set.
Over Current Protection (OCP):
 Fully protected against output overload and short circuit.
 The PSU will shut down after OCP is activated.
 Consult the factory for OCP setting.

GENERAL SPECIFICATION

Efficiency: Typical 87%-88% (various with the output voltage)
Switching Frequency: Typical 65KHz.
Circuit Topology: Fixed Frequency Flyback circuit.
Transient Response: Output voltage returns in less than 5.5mS following a 50% load change.
Safety Standard: Meet Medical IEC60601-1 & ITE IEC60950-1, Class I for DT7(C14) or Class II for DT8(C8)

Operating Temperature: 0°C to +40°C.
Storage Temperature: -20 to +85°C.
Cooling: Free air convection.
Construction: Impact resistant thermo-plastic enclosure case.
Power Density: 3.14-3.27Watts. / Cubic inch.
Desktop Format.

NOTE: (1) All measurements are at nominal input, full load, and +25°C unless otherwise specified.
 (2) Load regulation is measured at 115Vac or 230Vac in percentage to indicate the change in output voltage as the load varied from half load to full load ($\pm\%$).
 (3) The exact obtainable load regulation depends upon the output cord selected and load current.
 (4) Due to requests in market and advances in technology, specifications subject to change without notice.



For the details of safety approval, please consult the factory.

OUTPUT VOLTAGE / CURRENT RATINGS CHART

SINGLE OUTPUT

MODEL NO.	AC INLET	O/P VOLTAGE	O/P CURRENT
HEMG49-S120400-7	IEC320-C14(DT7)	12.0Vdc	4.0A
HEMG49-S120400-8	IEC320-C8(DT8)	12.0Vdc	4.0A
HEMG49-S150330-7	IEC320-C14(DT7)	15.0Vdc	3.3A
HEMG49-S150330-8	IEC320-C8(DT8)	15.0Vdc	3.3A
HEMG49-S240210-7	IEC320-C14(DT7)	24.0Vdc	2.1A
HEMG49-S240210-8	IEC320-C8(DT8)	24.0Vdc	2.1A

MECHANICAL DIMENSIONS: MM [INCHES]

WEIGHT: 373.0g (13.2 Oz.)

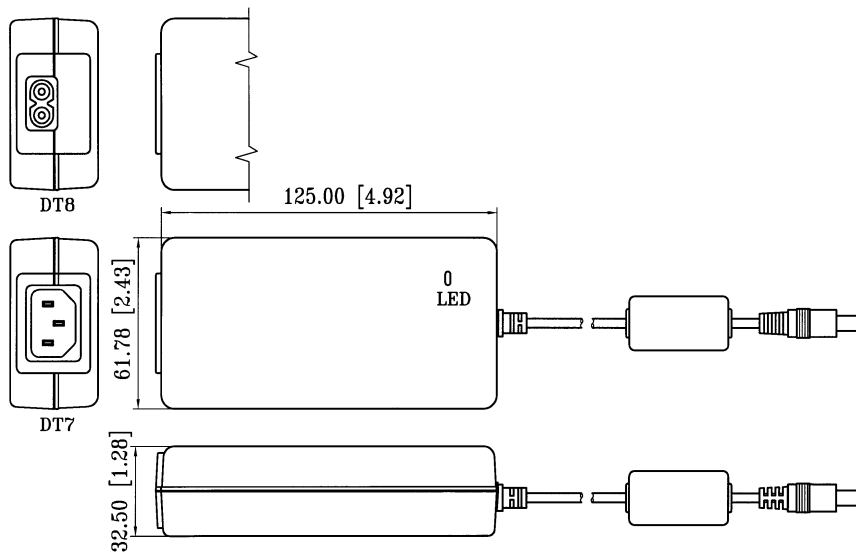

20.5 Instructions for integration into an IT-Network

The device, in conjunction with the connected computer and the device software running on it, forms a programmable electrical medical system (PEMS) according to IEC 60601-1.

It is essential that you follow the cybersecurity instructions section of "Safety Instructions" in the device instruction manual.

Please note the following information for implementing an integration of the PEMS into an IT-Network:

The purpose of integrating the PEMS into an IT-Network can be:

- Licensing by local license server
- Storage and retrieval of the examination data on a local network drive
- Printing
- Data export
- DICOM workflow

Required characteristics of the IT-Network into which the PEMS is to be integrated:

- Prefer wired LAN connection
- IPv4 network
- Fast-Ethernet (100 Mbit/s minimum)

Required configuration of the IT-Network into which the PEMS is to be integrated:

- Licensing: required opened ports: 3968 TCP; 51371 - 51372 UDP
- Storage, printing, data export: File and Printer Sharing for Microsoft Networks (SMB 3.0 or higher - required opened port: 445]
- DICOM Storage Service Class = PACS
- DICOM Worklist Management Service Class (Modality Worklist Server)

Technical specifications of the network connection with the PEMS, including the specifications of data security:

- Refer to the cybersecurity section of "Safety Instructions" in the device instruction manual.
- Refer to the "Floating License Key - License management for software options" instruction manual (if applicable)
- Refer to device specific DICOM interface description (if applicable)

The intended flow of information between PEMS, the IT-Network and other devices in the IT-Network and the intended routing through the IT-Network

- License handling from local license server to PEMS and vice versa
- Storage and data export to local network storage and loading from local network storage
- Printout to local printer

List of hazard situations that result from the IT-Network being unable to provide the features that are required to fulfill the purpose of integrating the PEMS into to meet the IT-Network:

- Loss of data
- unsuitable data exchange
- Data corruption
- unsuitable temporal data allocation
- unexpected data reception
- unauthorized access to data



Connection of the PEMS to an IT-Network that includes other equipment could result in previously unidentified risks to patients, operators or third parties.

The responsible organization should identify, analyze, evaluate and control these risks.

Subsequent changes to the IT-Network could introduce new risks and require additional analysis.

Changes to the IT-Network include:

- changes in IT-Network configuration
 - connection of additional items to the IT-Network
 - disconnecting items from the IT-Network
 - update of equipment connected to the IT-Network
-

Manufacturer and Service Address

Headquarters:

OCULUS Optikgeräte GmbH

Münchholzhäuser Straße 29 • 35582 Wetzlar • GERMANY

Tel. +49 641 2005-0 • Fax +49 641 2005-295

E-Mail: export@oculus.de • www.oculus.de

G/70100/EN
LOT
Rev03

