

OCULUS Easygraph



INSTRUCTION MANUAL

Measurement and Evaluation System
for Corneal Topography

Preface

The Easygraph was manufactured and tested under strict quality criteria. To ensure safe operation, it is essential that you use the device correctly. For this reason, you should thoroughly familiarize yourself with the contents of this instruction manual before operating the device. Pay attention to the safety instructions!

This instruction manual describes how to manage the patient data and the procedures for conducting measuring operations with the Easygraph:
Additional information that goes beyond the scope of this manual can be found in the Easygraph user manual.

Due to ongoing development, the diagrams shown here may vary slightly from the actual software delivered.

If you have any questions or would like additional information about your device, please do not hesitate to contact us by mail or fax. Our team will be happy to assist you.

OCULUS Optikgeräte GmbH

Article No.: G/70620/XXXX/EN

Revision: 02

Release: 08.10.2024

Table of Contents

1	Delivery and Deliverables.....	7
2	Symbols.....	8
2.1	On the Device / Name Plate.....	8
2.2	On the Packaging.....	9
3	Structure of the Documentation	10
4	Safety Instructions	11
4.1	Pictograms Used in this Manual.....	11
4.2	Safety Instructions for Use.....	12
4.3	Instructions for Operating Personnel	12
4.4	Transport and Storage Instructions.....	12
4.5	Instructions for Setup and Connection.....	12
4.6	Patient environment information.....	13
4.7	Information about the operation of an ME system.....	13
4.8	Instructions for Operation.....	14
4.9	Instructions for Maintenance.....	14
4.10	Instructions for Disassembly and Disposal.....	14
4.11	Instructions on Electrical Safety.....	14
4.12	Electromagnetic Compatibility (EMC) / Cables.....	15
4.13	Cyber Security.....	15
5	Intended Use.....	17
5.1	Intended Purpose.....	17
5.2	Intended medical indication.....	17
5.3	Contraindication	17
5.4	Potential Side Effects.....	17
5.5	Intended Users.....	17
5.6	Patient Group.....	17
6	Device Description	18
6.1	Device Components	18
6.2	OCULUS Easygraph Functionality.....	19
6.3	Applied parts.....	19
7	Set up and Connection	20
7.1	Mounting an Adapter for a Slit Lamp.....	20
7.2	Mounting the Parking Unit.....	22
7.3	Electrical Connection.....	22
8	Operation	25
8.1	Operating Conditions	25
8.2	Switching On.....	25
8.3	Switching Off.....	25
9	Perform Measurement.....	26
9.1	Starting the OCULUS Easygraph Software.....	26
9.2	Performing a Reference Measurement.....	27
9.3	Loading an Existing Examination.....	27
9.4	Print Screen.....	28
9.5	Preparing the Examination.....	28
9.5.1	Checking the Examination Conditions.....	29
9.5.2	Preliminary Adjustment	29

9.6	Starting the Examination	31
9.6.1	Manual Measurement	32
9.6.2	Marking the Placido Rings Manually	33
9.7	Ending of the measurement.....	34
10	Patient Data Management	35
10.1	Starting Patient Data Management.....	35
10.2	Entering a New Patient.....	36
10.3	Selecting an Existing Patient	36
10.4	Extended Patient Search	36
10.5	Rename Patient Data	37
10.6	Exporting patient data.....	37
10.7	Importing Patient Data.....	38
10.8	Data Backup.....	39
10.8.1	Backup Data	40
10.8.2	Reconstructing Data.....	41
10.8.3	Automatic Backup.....	41
11	Cleaning, Disinfection and Maintenance.....	42
11.1	Cleaning	42
11.2	Disinfection.....	43
11.3	Maintenance.....	43
11.4	Attaching Paper to the Chin Rest.....	44
11.5	Reference Measurement.....	44
12	Troubleshooting.....	46
13	Transport and Storage.....	47
13.1	Storage Conditions	47
13.2	Transport Conditions	47
13.3	Disassembly	48
14	Disposal	48
15	Terms of Warranty and Servicing.....	49
15.1	Terms of Warranty.....	49
15.2	Assumption of Liability for Functions and Damage.....	49
16	Technical Data	50
17	Annex.....	52
17.1	Electromagnetic Compatibility	52
17.2	Guidance and Manufacturer's Declaration - Electromagnetic Emissions and Immunity for the OCULUS Easygraph.....	53
17.3	Connection-Diagram.....	57
17.4	Data Sheet GEM 181 (05150980)	58

1 Delivery and Deliverables

Product and accessories	Order number
OCULUS Easygraph (measuring device) Protocol electrical safety	70620
Power Adapter	05150980
Reference sphere	08 70500 05 000
Dust cover	02 70620 00 004
Instruction Manual	G/70620 /EN
Software-Installation	SI/50000/.../EN
Connection cable (Y-cable EG GI-FS) 6 m	02 70620 00 071
Cable	05200320
OCULUS Easygraph Software OcuLicenseServer Software	referring to the Software version
Parking unit	01 70620 00 023
Holder, short	01 70620 00 059
Floating License Key (with Installation Manual)	77900
Viewing License Easygraph	70618
Fourier Easygraph	70619
Adapter for slit lamp, various types	available on request

Accessories (optional)	Order number
Chin rest	70518
Paper for chin rest	65313
DICOM	70630
OxiMap®	70627
Lens fitting	70626
Keratoconus package	70624

We reserve the right to change the scope of delivery in line with ongoing technical development.

- ➔ If you find transport damage upon delivery, immediately file a claim with the transport company.
- ➔ Have the damages noted on the bill of lading, so that your claim for damages can be handled properly.

For more information regarding shipping and handling, see [sec. 13, page 47](#).

2 Symbols

2.1 On the Device / Name Plate









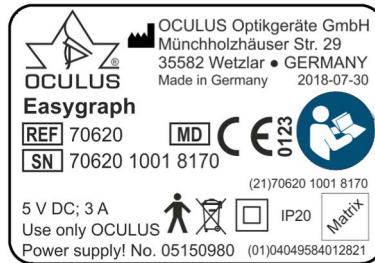

Abb. 2-1: Name plate (example)

Symbol	Description	Symbol	Description
	Manufacturer address and date of manufacture		Protection class
	Conformité européenne	IP XX	Type of protection
	Follow instruction for use		Article number
	Disposal in household trash is prohibited		Serial number
	Applied part Type B		Medical device
(21) ABCDEFG123456789 (01) 04049584000040		Example: UDI number, consisting UDI-DI (Device-Identification) UDI-PI (Product Identifier) machine-readable matrix code	

2.2 On the Packaging

Symbol	Description
	Keep dry
	This way up
	Fragile
Transport	
	Limit of temperature for transport
Storage	
	Limit of temperature for storage
	Limit of humidity
	Limit of air pressure

3 Structure of the Documentation

A folder containing documentation is supplied with your OCULUS Easygraph:

- **Instruction Manual:** The design of the unit is described in detail in this document. The instruction manual also gives you general information about working with the Patient Data Management system and all safety-related instructions for use of the OCULUS Easygraph.
- **User Guide:** All features of the examination and analysis software are described in the User Guide, along with detailed information about the Patient Data Management system.
- **Software Installation:** The introduction to the Software Installation describes how to install the OCULUS Easygraph software and the associated drivers.

If you work with a Floating License Key, please consult the corresponding manual for information on the use of the OCULUS Easygraph within networks.

External software: „Description of external Software data interface“ describes settings and data formats.

4 Safety Instructions



Attention

All safety-related instructions for use of the OCULUS Easygraph are given in the Instruction Manual for the unit. It is imperative that you read and understand the whole Instruction Manual before you use the OCULUS Easygraph.

- ➔ Carefully read through the Instruction Manual.
- ➔ Keep the Instruction Manual in good condition near the device.
- ➔ Observe the legal regulations with regard to accident prevention.

4.1 Pictograms Used in this Manual



Attention

Identifies a potentially dangerous situation which may cause minor injury or damage to property.



Note

Denotes situations which could result in incorrect findings, denotes user instructions and useful or other important information.



Identifies important information about the product and its use which require special attention.

- > This symbol denotes menu paths and screen shots. Example for starting a new examination:
OCULUS Easygraph > Examination > New
which means:
 - ➔ Select the "Examination" menu from the menu bar.
 - ➔ Select the menu item "New".

4.2 Safety Instructions for Use



Attention

Personal injury or property damage due to improper operation

- Observe the following safety instructions.



Attention

Personal injury or property damage due to equipment modifications that could jeopardize safety

- No modifications may be made to this device without the permission of the manufacturer. Only the OCULUS service and authorized dealers are allowed to modify the device.

Report any severe incidents that occur in connection with the product to the manufacturer (vigilance@oculus.de) and the competent authority of the Member State where you and/or your patient are located.

4.3 Instructions for Operating Personnel

- Make certain that the OCULUS Easygraph is used exclusively by personnel who have the training and practical experience to safely and properly operate the equipment.

4.4 Transport and Storage Instructions

Refer to the notes in *sec. 13, page 47*.

4.5 Instructions for Setup and Connection

- Only OCULUS or an authorized dealer is allowed to set up and to connect the OCULUS Easygraph.
- Do not use or store the OCULUS Easygraph in rooms that are humid.
- Keep the OCULUS Easygraph away from water that may drip, splash or spray on it, and make sure that no liquids can get into the OCULUS Easygraph. Do not place any containers holding liquids in the vicinity of the OCULUS Easygraph.
- Germany: Only operate the OCULUS Easygraph in rooms used for medical purposes after they have been set up according to the VDE Regulation 0107.
- Do not operate the devices included in the delivery in areas where explosions may occur, or in proximity to flammable anesthetics or volatile substances such as alcohol, benzene or similar products.
- Set up the OCULUS Easygraph so that the power plug is easy to access. That way, you can easily disconnect it from the power supply for any repairs or maintenance work.

- ➔ Do not use excessive force when connecting the electrical plug. If a connection is not possible, check whether the plug fits the socket. If you find damage to the plug connector, have the damage corrected by our service department.
- ➔ Only use a device which is mounted properly.

4.6 Patient environment information

Patient environment is the area where patients can come into contact with any part of a medical electrical equipment (ME equipment) or with another person being in contact with the ME equipment.

In the patient environment, use devices that conform to IEC 60601-1. If a multiple power socket is to be used, or if a device is to be used that does not meet the IEC 60601-1 standard, use an isolating transformer.

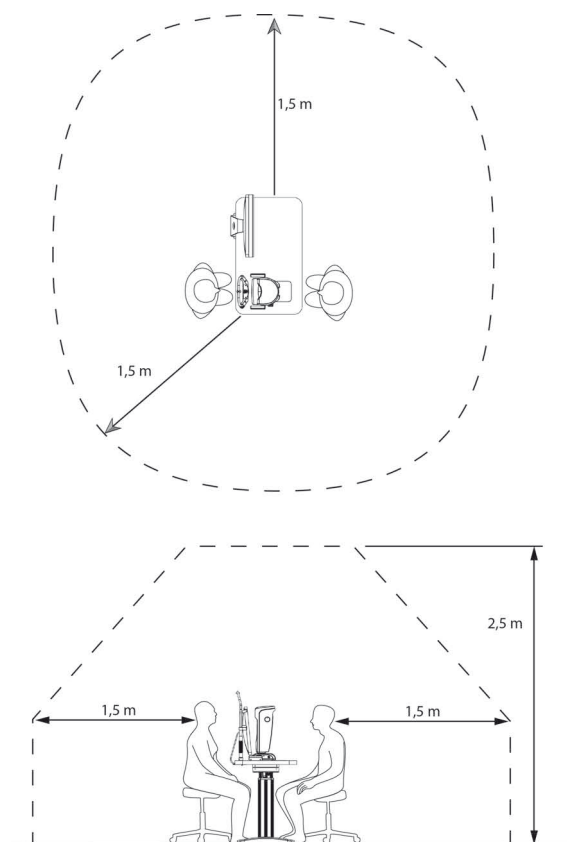

Fig. 4-1: Patient environment

4.7 Information about the operation of an ME system

The OCULUS Easygraph and a connected computer form a medical electrical system (ME system) according to DIN EN 60601-1. If you connect additional devices, such as, for example a printer, those devices become part of the ME system.

- ➔ Make sure that all devices of the ME system meet the requirements of IEC 60601-1 or IEC 60950-1

4.8 Instructions for Operation

- Never operate a damaged OCULUS Easygraph.
- Only operate the OCULUS Easygraph with the original accessories supplied by us and only when the unit is in technically perfect condition.
- Before first use: Let OCULUS or an authorized dealer train you in the operation of the OCULUS Easygraph.
- Do not cover the ventilation openings.
- Only operate the device if you have understood the operating instructions.

4.9 Instructions for Maintenance

To ensure satisfactory and reliable operation, we recommend that you have the OCULUS Easygraph checked every two years by our service department or an authorized dealer. If an error occurs which you cannot correct, label the OCULUS Easygraph as being "out-of-order" and contact our service department.

4.10 Instructions for Disassembly and Disposal

- When disconnecting electrical connections, pull on the respective plug and not on the cable itself.
- Dispose of the device according to legal regulations.

4.11 Instructions on Electrical Safety



Attention

Risk of personal injury or damage to property due to an incorrect level of safety

Connecting the OCULUS Easygraph with its non-medical electrical equipment (e.g. data processing equipment) to a medical electrical system must not result in a patient safety level below that prescribed by DIN EN ISO 60601-1. If making this connection leads to the leakage current threshold being exceeded, protective measures including a circuit breaker must be in place.

- Ensure that connections with non-medical devices are made correctly.
- Only use the power adapter listed in the packing list.
- Use only a computer that meets the specifications given in this instruction manual, [sec. 17, page 52](#).



Attention

Use of a multiple socket extension cord

Risk of personal injury or material damage caused by unsafe multiple socket extension cord

If you use a multiple socket extension cord to connect the OCULUS Easygraph to the power supply, you must heed the following information:

- Use an extension cord that complies with the requirements of IEC 60601-1, section 16.
- Do not place the multiple socket extension cord on the floor.
- Do not use more than one multiple socket extension cord.
- Plug only the OCULUS Easygraph and the computer that is being used with the unit (if applicable) into the multiple socket extension cord.

If you are using a multiple socket extension chord it has to be supplied with a isolation transformer.

If you are using a new computer for the OCULUS Easygraph, you must have the electrical safety checked. Call OCULUS Service for this purpose.

4.12 Electromagnetic Compatibility (EMC) / Cables

Risk of personal injury or damage to property due to electromagnetic interference

Portable and mobile RF communications equipment can affect medical electrical equipment *sec. 17, page 52*.

- Make sure that portable and mobile RF communications equipment do not cause interference.
- Recommendation: Maintain a minimum distance of 4 m. If the distance is shorter, you must ensure that the OCULUS Easygraph functions correctly.

4.13 Cyber Security



Always use a wired connection to transfer examination data from the device to the PC. Do not use wireless technologies.

To ensure cyber security in order to the usage of the device, the following security measures should be considered. Contact your computer administrator:.

Precautions for access control of the computer

- Secure the computer with a password (for example at Windows start up).
- Choose a complex password: A good password should be at least eight characters long and are not in the dictionary. In addition to letters, it should also include numbers and special characters.
- Do not choose a name or device name for a password (for example "Easygraph").
- Change the password regularly.
- Do not note the password in an accessible location.

- Use different passwords for different users.
- Enable the screen saver and use the option for the necessity of re-entering the password when exit the screen saver.
- Choose an adequate time setting for starting the screen saver if software session is inactive (e.g. 10 minutes). Adequate time setting should consider duration of examination, number of patients, time between examinations, use of other devices in the examination room, several user, etc.
- Lock the computer if you are leaving the workstation (shortcut: 'windows logo key' + 'L').

Precautions if the computer is connected to a LAN or internet network

- Prefer wired connections of the computer to the network.
 - If you are using Wi-Fi connections nevertheless, please ensure the usage of adequate security methods (for example WPA2/AES – Wi-Fi Protected Access / Advanced Encryption Standard – with a strong network key).
 - The usage of a firewall (software or hardware) is recommended.
- Recommendation: Use anti-malware tools with up to date malware definitions.



Note

Also observe the regulations, instructions and recommendations of your local authorities for information technology security for the protection of critical infrastructures.

5 Intended Use

5.1 Intended Purpose

The OCULUS Easygraph is a measuring device for eye examination and measures the surface of the cornea (corneal topography). The OCULUS Easygraph is therefore intended for use in individual contact lens fitting. The OCULUS Easygraph is to be used in conjunction with the designated examination station or on an examination unit.

The OCULUS Easygraph may only be used for the purpose stated in these instructions for use, which includes in particular observing the safety instructions.

5.2 Intended medical indication

The OCULUS Easygraph can be used to examine the following:

- Corneal topography for contact lens fitting

5.3 Contraindication

none known

5.4 Potential Side Effects

none known

5.5 Intended Users

The OCULUS Easygraph is intended exclusively for use in:

- Eye specialists practices
- Clinics
- At opticians or optometrists

The OCULUS Easygraph is intended for use by trained staff:

- Who, based on their knowledge, training and practical experience, can ensure professional handling.
- Who have been instructed by OCULUS personnel or an authorized dealer prior to putting the device into operation.

5.6 Patient Group

Children from 3 years up to unlimited.

No restrictions regarding weight and state of health: The patient is awake and able to understand and see a fixation object.

6 Device Description

6.1 Device Components



Abb. 6-1: Device components

- | | |
|-------------------------------------|------------------|
| 1 OCULUS Easygraph | 5 Camera opening |
| 2 Gripping surfaces for better grip | 6 Test marks |

- 3 Y-cable connector
- 4 Name plate

- 7 Calotte

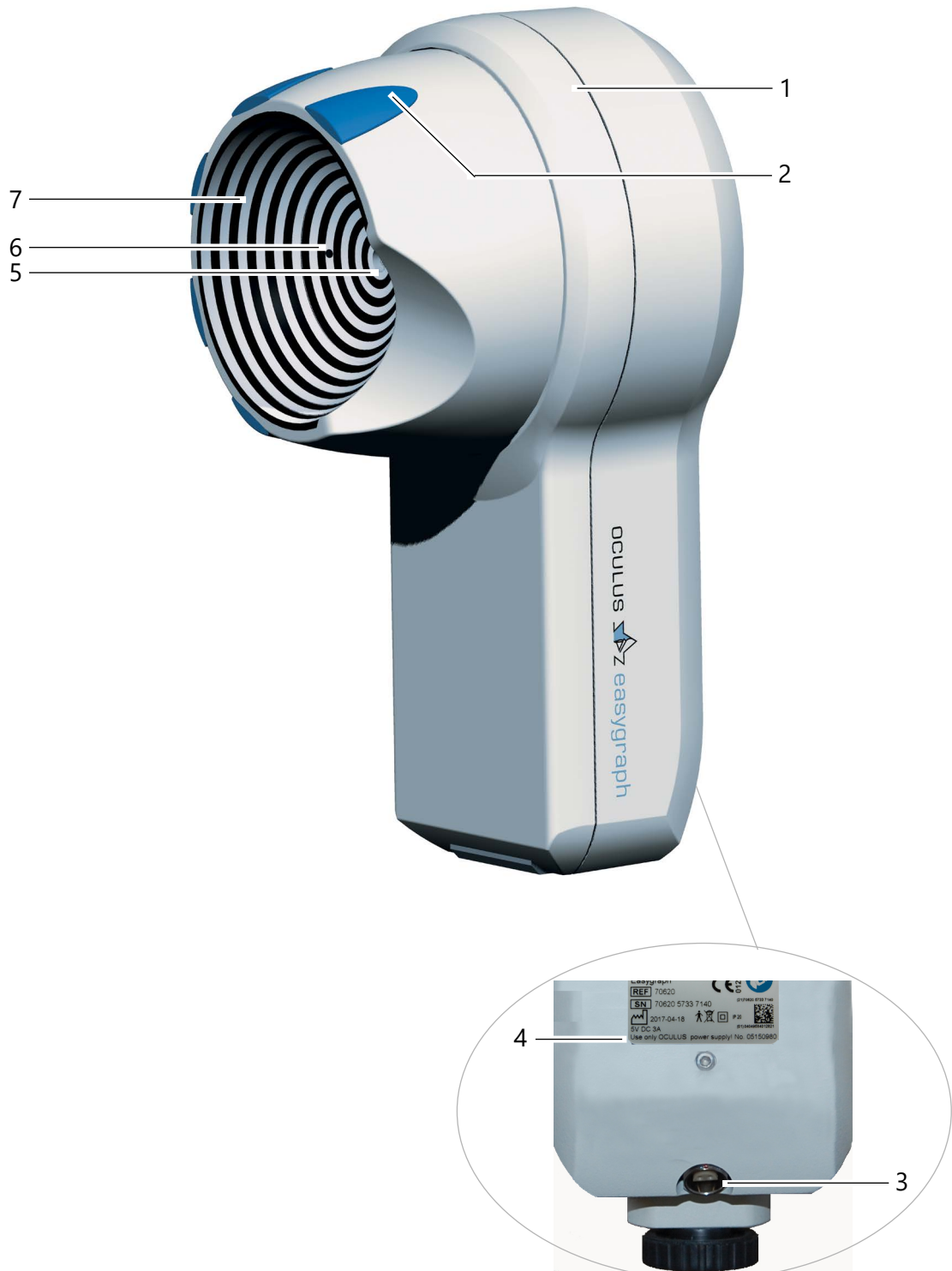
6.2 OCULUS Easygraph Functionality

The OCULUS Easygraph combines the keratometric measuring process with topographic mapping.

Measurement of the corneal surface is done by means of a Placido ring system that is reflected off the cornea. These data are analyzed by the computer.



Note

Data misuse

OCULUS Optikgeräte GmbH shall not be liable in any form for further use of the data recorded with the OCULUS Easygraph or for any calculations based thereon

An illumination system with a special reflector illuminates a transparent Placido bowl from the rear which contains a series of concentric rings . The image of this Placido bowl is reflected off the patient's eye. This virtual image is captured by a precision objective and a connected camera.

All distortions due to the different radii of curvature of the patient's eye that become visible are available for the measuring process.

The analog image is first prepared for analysis in the measuring unit, for example it is digitized and compressed for processing in the computer. When the computer has received the respective dataset for the measurement image, it develops a topographic map of the cornea based on that data.

It displays the measurement results on the monitor as a color map, a graph and as a spatial image.

6.3 Applied parts



Abb. 6-2: Applied parts

- 1 Headrest

- 2 Chinrest

7 Set up and Connection

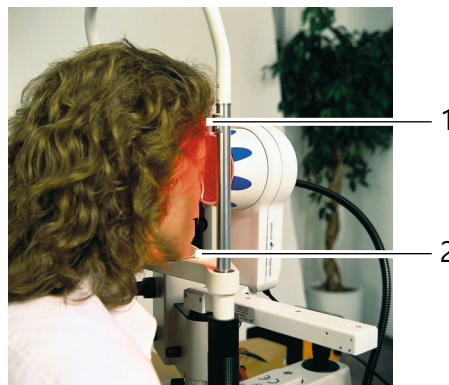

Attention

Risk of incorrect measurements/equipment damage due to improper setup

Before first use

- Make sure the installation and connection of the "OCULUS Easygraph" examination station are completed by our service or by a professional authorized by OCULUS.
- Let OCULUS or an authorized dealer train you in the operation of the OCULUS Easygraph.



Note

- Do not expose the OCULUS Easygraph to any vibrations, shocks, contaminants, moisture, or high temperatures.
- Handle the optical device with care.
- Set up the OCULUS Easygraph so that the power plug is easy to access. That way, you can easily disconnect it from the power supply for any repairs or maintenance work.
- Place the device so that direct light cannot affect the measurement.
- Make sure the examination is free from reflections. To achieve this, darken the examination room.

7.1 Mounting an Adapter for a Slit Lamp

You can use the OCULUS Easygraph for all common slit lamps. Use the enclosed holder.



This holder is designed for slit lamps with a drilling of 8mm diameter. It is possible to get other holders on request.

- ➔ Screw the holder with the knurled screws to the OCULUS Easygraph.



Abb. 7-1: Mounting the holder

- 1 Holder
- 2 Knurled screws

- ➔ If required: Take off the cover of the slit lamp receptacle .



Abb. 7-2: Mounting on a slit lamp

- 1 Holder
- 2 Receptacle of the slit lamp

- ➔ Set the shaft of the Easygraph holder (1) in the receptacle of the slit lamp (2).

7.2 Mounting the Parking Unit

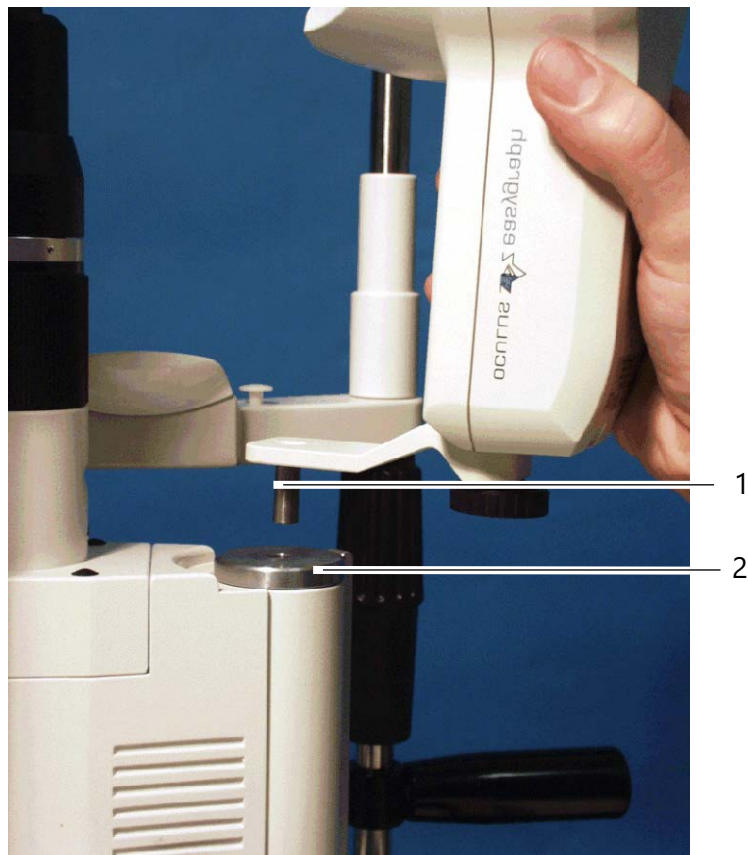
If the OCULUS Easygraph is not required during an examination, you can use parking unit to "park" the OCULUS Easygraph temporarily.



Abb. 7-3: Mounting the parking unit

1 Parking unit

- ➔ Screw the parking unit (1) with the enclosed screws e.g. to the examination table.
- ➔ Insert the OCULUS Easygraph with the adapter in the parking unit.

7.3 Electrical Connection

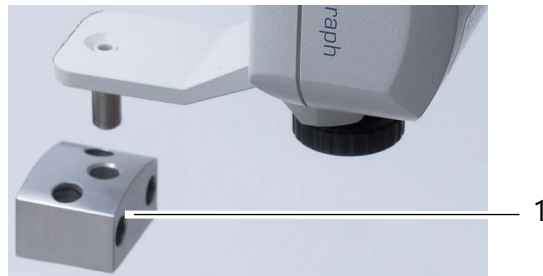

Attention

Electrical safety hazard

- ➔ Do not use the OCULUS Easygraph immediately next to other devices. Do not stack it with other devices. Exceptions are the provided examination room or the examination unit including a slit lamp, *sec. 17, page 52*.
- ➔ Only use the power adapter listed in the packing list.
- ➔ If you use a power strip to connect the OCULUS Easygraph: Use a power strip that complies with the requirements of DIN EN 60601-1.
- ➔ Do not place the multiple socket extension cord on the floor.
- ➔ Do not use more than one multiple socket extension cord.
- ➔ Plug only the OCULUS Easygraph and the computer that is being used with the unit (if applicable) into the multiple socket extension cord.
- ➔ Use a socket with a protective earth connection which is fully operating.

The Easygraph may be operated only with the supplied plug-in power supply unit. To adapt to different countries the plug-in power supply unit has replaceable plug adapters for connection to the mains and a wide range input.

- ➔ Select the adapter corresponding to your country.

- ➔ Push it into the plug-in power supply unit until it snaps into place.



Abb. 7-4: Mounting an adapter corresponding to your country (example: power supply)

- ➔ Plug the plug-in of the y cable into the jack.



Abb. 7-5: Connecting

- ➔ Make sure that the plug is inserted in the correct position. When connecting, all the dots should be in arrow.



Note

Risk of equipment damage due to incorrect connection

If you do not connect the OCULUS Easygraph properly, and the connection is live, the unit can be damaged within a short period of time.

- ➔ Do not use excessive force when connecting the electrical plug.
- ➔ Pay attention to the specifications on the name plate.

If the electrical plug is damaged, contact our service department or an authorized dealer to repair the damage.

- Connect the Y cable to the computer/laptop (1) and the power adapter (2).

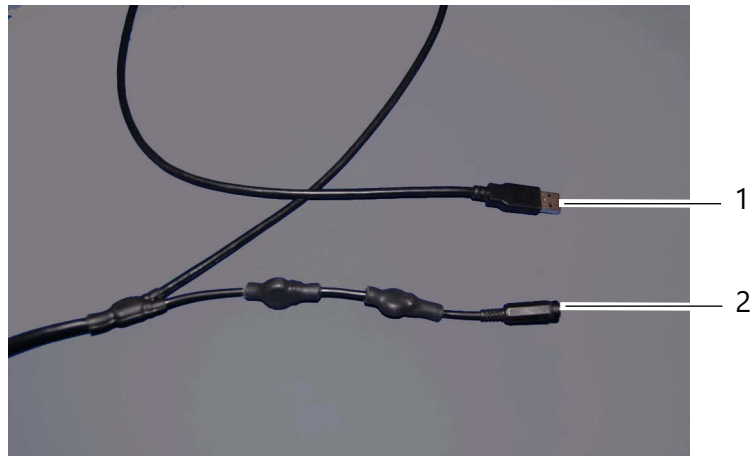

- 1 USB connector for computer/
Laptop
- 2 Connector for power adapter

Abb. 7-6: Connecting y cable

8 Operation



The Instruction Manual concentrates on how to operate the OCULUS Easygraph.

The functional description of the Easygraph software is therefore limited to the respective measuring procedure and to loading existing examinations.

For detailed information about measurement evaluations, please refer to the User Guide.



Before the initial operation:

→ Install the software as described in the [software installation](#).

→ Wait approx. 3-4 hours after transport before operating the OCULUS Easygraph for the first time. Extreme temperature changes from cold areas to warm rooms can cause condensation on the optical components.

8.1 Operating Conditions

Temperature	+10°C to +40°C
Humidity	30% to 75%,
Air pressure	700 hPa to 1060 hPa

8.2 Switching On

- The first step is to switch on the computer or laptop.
- Plug in the mains plug ([fig. 7-5, page 23](#)) and switch on for example the table unit or the slit lamp unit.

8.3 Switching Off

- Close the OCULUS Easygraph program and close the Patient Data Management.
- Shut down the Windows operating system.
- Turn off for example the table unit or the slit lamp unit. Disconnect the mains plug ([fig. 7-5, page 23](#)). Pull on the plug and not on the cable itself.

9 Perform Measurement

9.1 Starting the OCULUS Easygraph Software

You start the OCULUS Easygraph software from the patient data management. You have the following options:

- ➔ After selecting a patient: Double click on an examination from the examination list to start the OCULUS Easygraph program.



Abb. 9-1: Overview example with a topographic examination

- or
 - ➔ After selecting a patient: Press the [Easygraph] button to start the OCULUS Easygraph program.
 - or
 - ➔ Double-click the selected patient name to start the OCULUS Easygraph program.
- The following items are displayed on every screen.

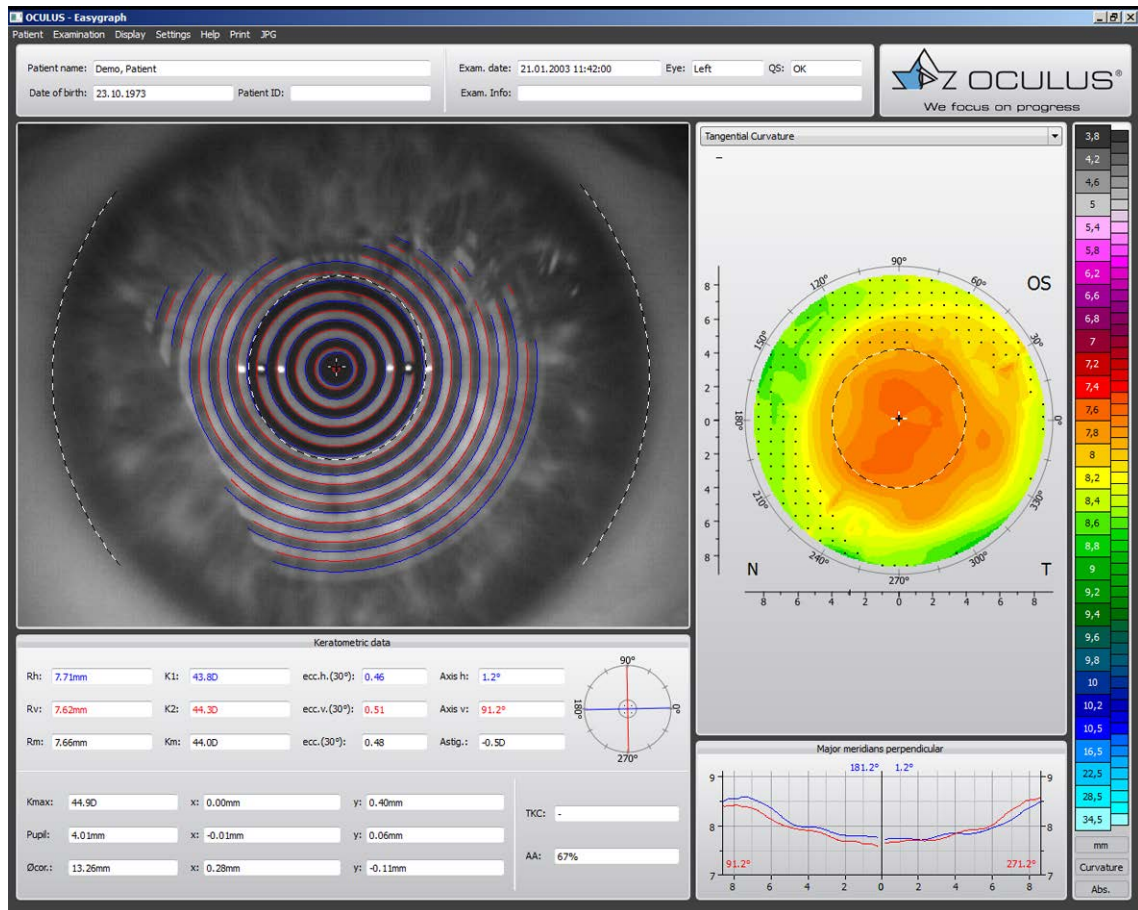

Abb. 9-2: OCULUS Easygraph program menu bar

9.2 Performing a Reference Measurement

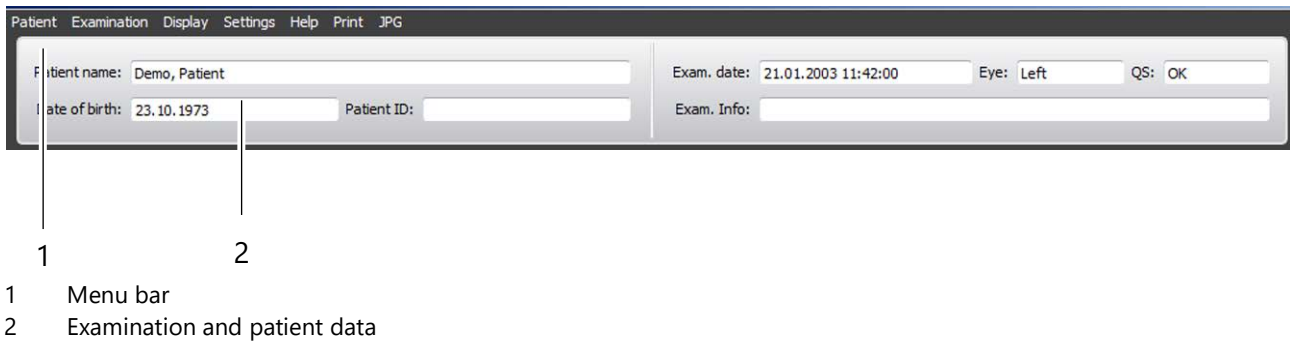

Before the first measurement you need to perform a reference measurement.

- ➔ Select the menu item [Settings].
- ➔ Choose [Reference Measure].
For how to perform a reference measurement see [sec. 11, page 42](#).

9.3 Loading an Existing Examination



Attention

Risk of incorrect measurement due to incorrect use
Before first use

- ➔ Make sure the installation and connection of the "OCULUS Easygraph" examination station are completed by our service or by a professional authorized by OCULUS.
- ➔ Let OCULUS or an authorized dealer train you in the operation of the OCULUS Easygraph.

- ➔ Select the menu item [Examination] and click [Load old examination].
This opens the "LoadExaminationDialog" screen.



Abb. 9-3: Choose examination and load it.

- ➔ Select the desired examination by clicking on it.
- ➔ Confirm your selection by clicking [OK], or by double clicking. The OCULUS Easygraph program will load the examination you have selected.

9.4 Print Screen

- ➔ Select the menu item [Print]. The Print menu appears.
- ➔ Select the desired printer and enter the settings.
- ➔ Press the [Print] button. The currently displayed screen is printed.

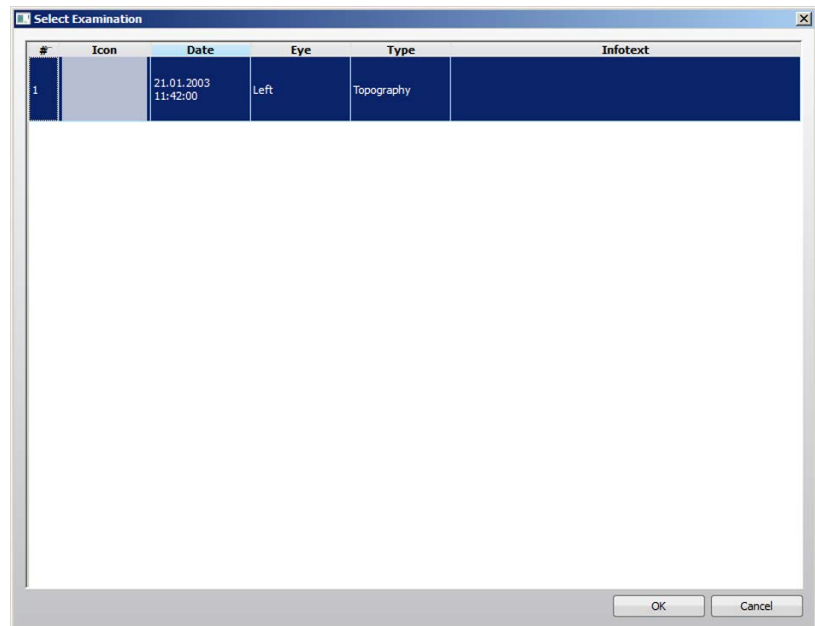
9.5 Preparing the Examination



Attention

Risk of incorrect measurement due to incorrect use
Before first use:

- ➔ Make sure the installation and connection of the "OCULUS Easygraph" examination station are completed by our service or by a professional authorized by OCULUS.
- ➔ Let OCULUS or an authorized dealer train you in the operation of the OCULUS Easygraph.



Recommended for beginners: Practice the entire measurement process a few times using the supplied reference sphere ([sec. 9.1, page 26](#)).

- ➔ Align the OCULUS Easygraph parallel with the chin rest



Abb. 9-4: Align Easygraph parallel

9.5.1 Checking the Examination Conditions

- ➔ Make sure that no interfering light gets into the viewer of the OCULUS Easygraph.
If necessary, darken the room.

9.5.2 Preliminary Adjustment

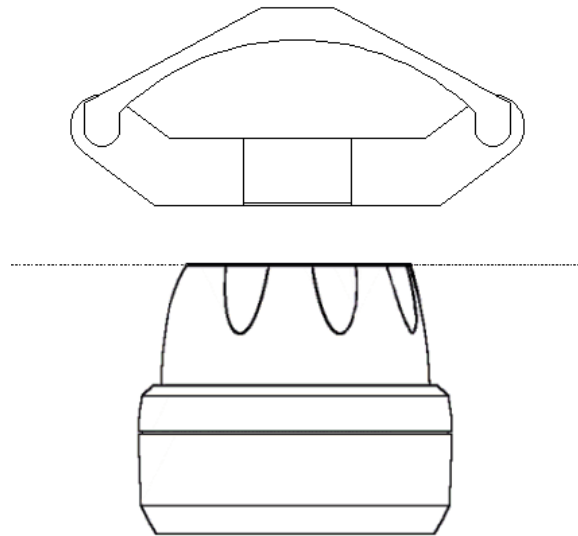
- ➔ Check that fresh paper has been put onto the chin rest, [sec. 11.1, page 42](#). If you do not use chin rest paper: Disinfect the chin rest after each examination.
- ➔ Check that the forehead rest has been cleaned and disinfected after each examination, [sec. 11.2, page 43](#).
- ➔ Ask the patient to put his chin on the chin rest.
- ➔ Do not touch the patient and the OCULUS Easygraph simultaneously.
- ➔ Position the reflector for the right or left eye.
Turn the reflector until it snaps in noticeably.



1 Measuring left eye

Measuring righteye

Abb. 9-5: Position reflector for measurement

- ➔ Adjust the height of the table so that the patient's head rests comfortably on the chin-forehead rests.
- ➔ Adjust the chin rest so that the patient's eyes are approximately at the level of the black ring on the chin-forehead rest (1).

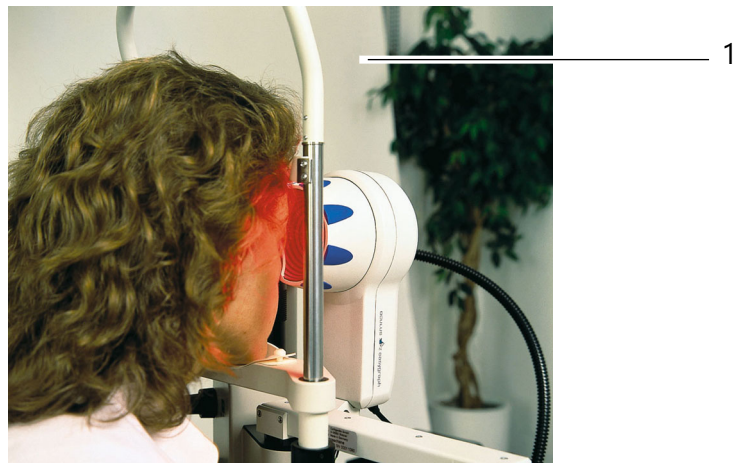

1 Chin-forehead rest

Abb. 9-6: Patient positioning

- ➔ If required: adjust the position with the adjusting mechanism of the slit lamp.
- ➔ Instruct the patient to focus on the red light in the center of the rings during the entire measurement.

9.6 Starting the Examination

- ➔ In the "Examination" menu, select [New].
The following screen will appear:

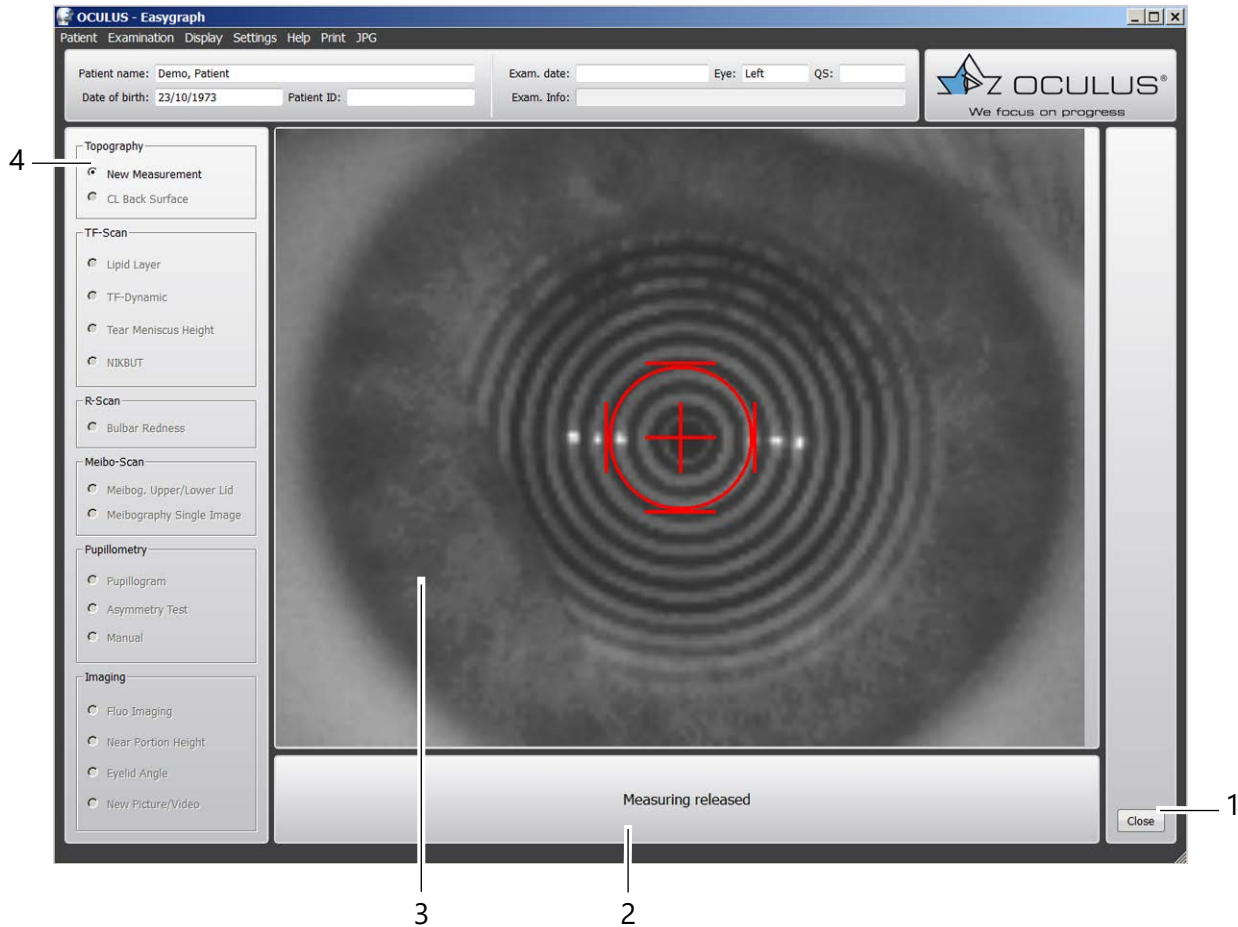

- 1 [Close] button
- 2 [Measuring released] button
- 3 Current camera image with cross hair
- 4 Examination bar

Abb. 9-7: Overview of the exams, topography example

The examinations are listed in the examination bar (4). Examinations that are not activated are grayed out.



See the User Guide for information about the evaluation of the examinations.

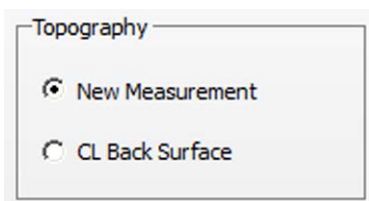

- ➔ Enable the [New Measurement] radio button.
- ➔ If required: adjust the camera, [sec. 9.7, page 34](#).

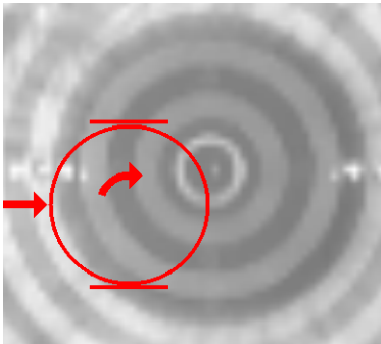

- ➔ Position the measuring head in front of the eye so that the keratometry marks are in focus (see figure).
- ➔ Precisely align the camera. To do so, move or turn the joystick in the specified directions:

Example:

- ➔ Move the joystick to the right.
- ➔ Rotate the joystick clockwise.

Arrow	Camera movement	Joystick movement
➔	right	Move the joystick to the right
➜	left	Move the joystick to the left
⬆	forward	Move the joystick toward the patient
⬇	back	Move the joystick away from the patient
↻	up	Rotate the joystick clockwise
↺	down	Rotate the joystick counter-clockwise

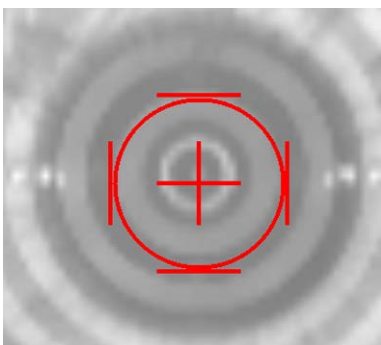

When the position has been approximately reached, a cross appears in the center of the ring that is bordered by four bars. The OCULUS Easygraph will automatically begin measuring.



Note

A poor tear film quality or highly irregular corneas can affect the quality of the captured image, or prevent automatic triggering of the measurement from occurring.

- ➔ You can improve the image quality by placing a drop of artificial tears into the eye that is to be examined.

9.6.1 Manual Measurement

In rare cases, e.g. when highly irregular corneas are present, the measurement cannot be triggered automatically.

- ➔ Pressing the spacer bar and then the Enter key. The measurement is triggered manually. A manually triggered measurement may not be reproducible.

9.6.2 Marking the Placido Rings Manually

If considerable corneal irregularities are present, the keratometry marks may not be on a plane with the center point of the Placido rings. Automatic analysis of the topography data is then not possible. In that case, you will be prompted to manually mark the center of the Placido rings.

- ➔ Click with the left mouse button on the center point of the rings projected on the cornea.
The topography of the cornea is then calculated.



Abb. 9-8: Marking the Placido rings manually



Note!

The topographic measurements will automatically be stored.

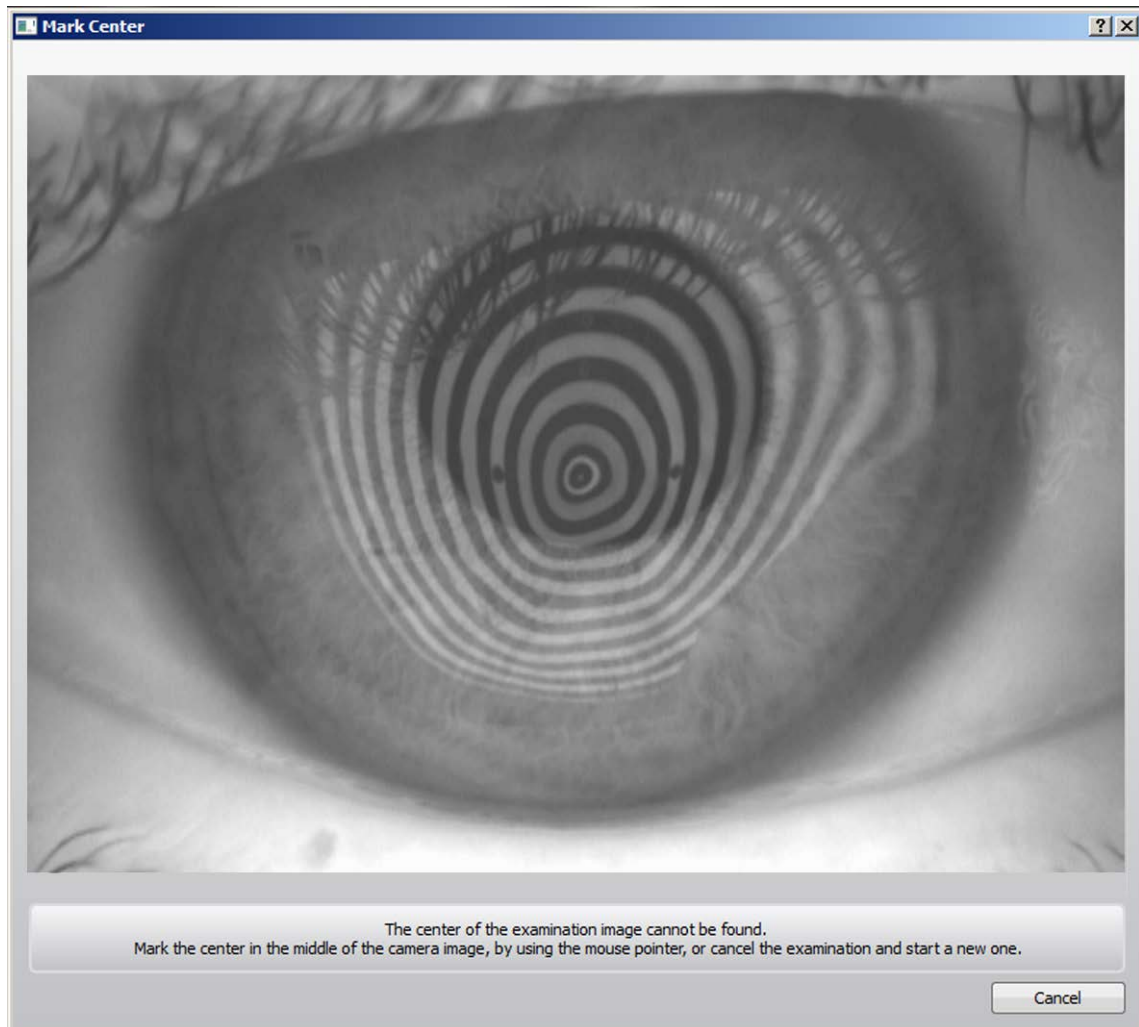
9.7 Ending of the measurement

- ➔ Ask the patient to remove his chin from the chin rest.
- ➔ Clean the frame of the reflector and the blue gripping surfaces after every examination, see "[Cleaning the Frame of the Reflector](#)" auf Seite 42.
- ➔ If required: Prepare the examination of a new patient. Change chin rest paper.
- ➔ Select on the menu bar "Patient" and click [New patient/End].

Once you have completed an examination, you can do the following with the patient data

- Rename it, [sec. 10.5, page 37](#)
- Export it, [sec. 10.6, page 37](#)
- Import it, [sec. 10.7, page 38](#)
- Save it, [sec. 10.8, page 39](#)



For more information on Patient Data Management, refer to the [User Guide](#).

10 Patient Data Management

You can enter patient data in the Patient Data Management and then use it.

10.1 Starting Patient Data Management

After you have switched on the computer, it loads the operating system.

➔ If necessary, click on the OCULUS Easygraph icon: .

The user interface for the Patient Data Management appears

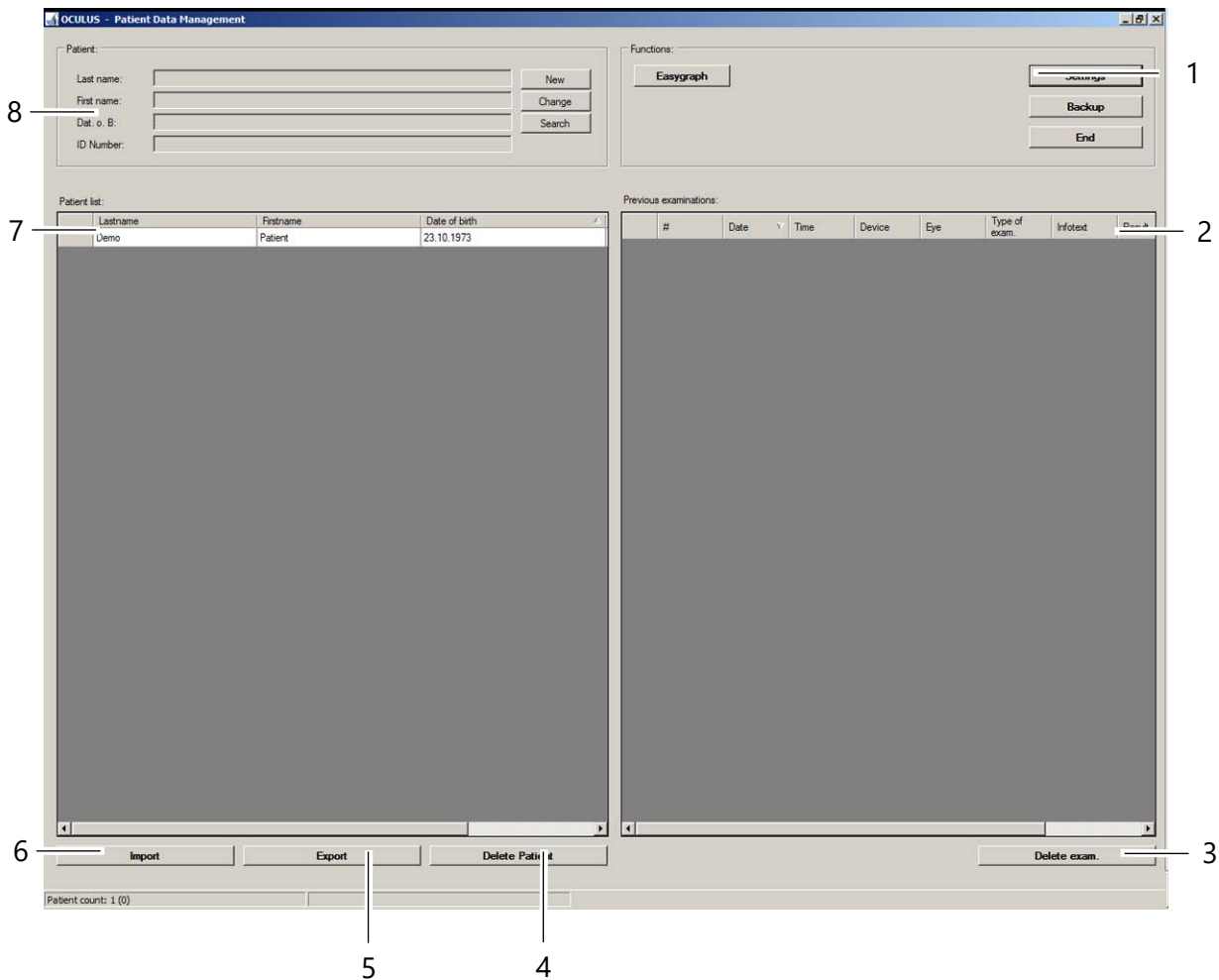

- | | |
|---------------------------|-----------------------|
| 1 "Functions" group box | 5 [Export] button |
| 2 Previous examinations | 6 [Import] button |
| 3 [Delete exam.] button | 7 Patient list |
| 4 [Delete Patient] button | 8 "Patient" group box |

Abb. 10-1: Patient Data Management user interface



To get to the OCULUS Easygraph program, you must first enter a new patient (8) or select an existing patient from the examination list (2). For more information on Patient Data Management, refer to the [sec. 9.7, page 34](#).

10.2 Entering a New Patient

- ➔ Press the [New] button to enter a new patient in the Patient Data Management system.
- ➔ Enter the patient's last name, first name and date of birth in the patient window.



Abb. 10-2: Entering patients

- ➔ Optionally you can enter an ID number for the patient.
- ➔ To save the data you entered, click [Save].
The patient you have just entered now appears in the patient list.

10.3 Selecting an Existing Patient

The patient data list on the left-hand side of the screen displays all previously examined patients in alphabetical order.

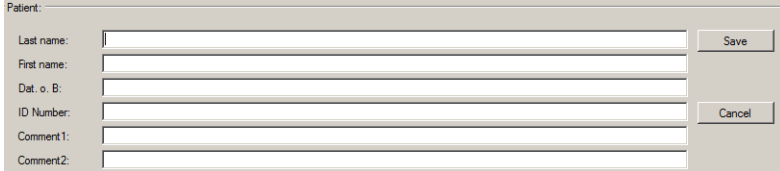
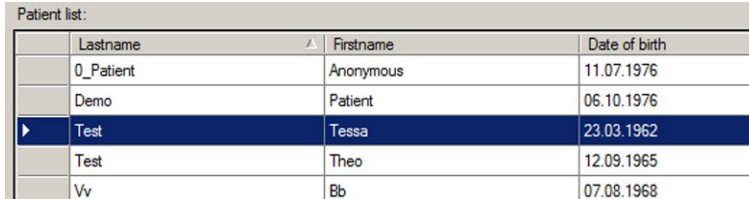

Lastname	Firstname	Date of birth
0_Patient	Anonymous	11.07.1976
Demo	Patient	06.10.1976
Test	Tessa	23.03.1962
Test	Theo	12.09.1965
Vv	Bb	07.08.1968

Abb. 10-3: Patient list

- ➔ Choose [Search] to quickly find the patient you are looking for in the list.
- ➔ Enter the patient's name or the first letter of the name in the "Last name" field.
Alternatively, you can search for the patient using an ID number, first name or date of birth, assuming that one was assigned when the patient was first recorded.
- ➔ In the list that appears, click the entry you were searching for to transfer the patient's name to the patient window. This also brings up a list of any previous examinations for that patient in the examination window (bottom right side).

10.4 Extended Patient Search

- ➔ Click on the [Extended] checkbox.
The screen displays additional search parameters which reference previous examinations. Proceed as for the input of a patient name.



Abb. 10-4: Advanced search

10.5 Rename Patient Data

After creating of the patient data, you can edit it.

- ➔ Press the [Change] button.
The input boxes for patient data are now enabled, and the cursor jumps to the "Last name" field.
- ➔ Change the entries in the individual boxes.
- ➔ Press the [Save] button.

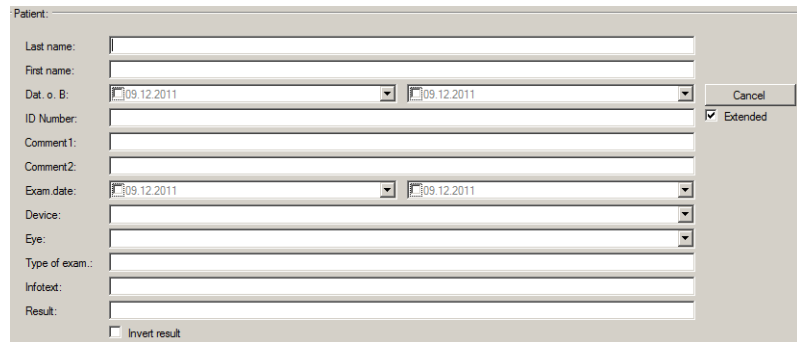
10.6 Exporting patient data

Patient and examination data can be exported, for example, for forwarding to another clinic.

- ➔ Select the patient and also one of the examinations in the respective list as required.
- ➔ Press the [Export] button below the patient list. The following dialog will be displayed:

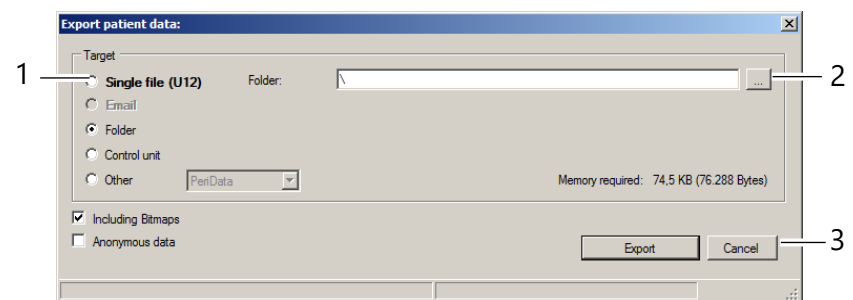

- 1 Saving destination selection
- 2 [...] button
- 3 [Cancel] and [Export] buttons

Abb. 10-5: "Export patient data" dialog



The default options for import and export of data are configured in the "Settings" field, see also the [User Guide](#).

Depending on the settings, you may not have to perform all of the following steps (e.g. selection of the directory).

- ➔ Select the "Target" (1) where you would like to export the data.



Recommendation: Export the patient data using the "Single file (U12)" option.

- ➔ Press the [...] button. (2).
- ➔ In the dialog that appears, select the folder or the file to which the patient data should be exported.
- ➔ Confirm your selection with [OK] or [Open].
- ➔ To export the data, press the [Export] button (3).

10.7 Importing Patient Data

If you receive patient data, for example, on a USB stick, you can import these data.



Note

Risk of loss of data due to computer viruses
 Computer viruses can cause loss of data.

- ➔ Run a virus check before importing data from the USB flash drive.

- ➔ Press the [Import] button.
 The following dialog appears:

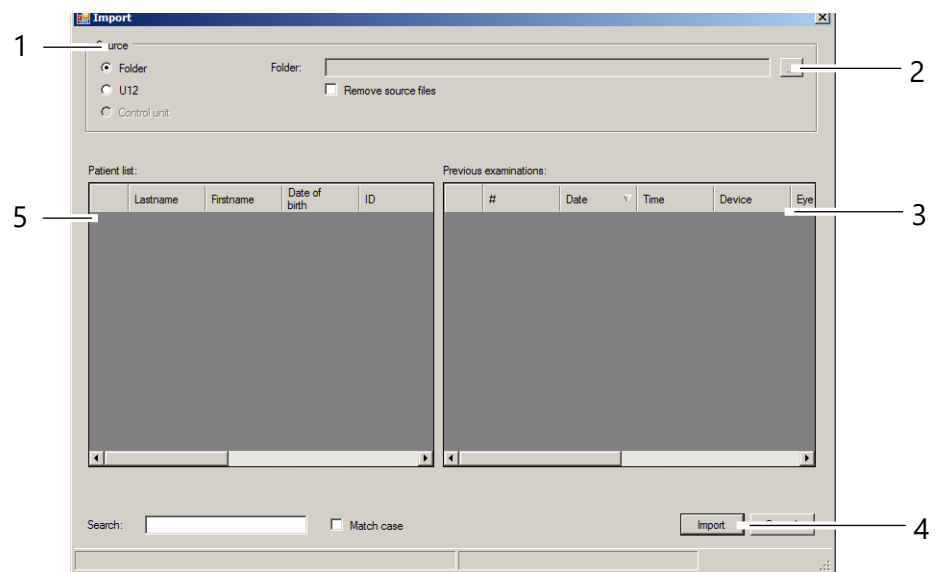

- | | |
|-------------------------|-------------------|
| 1 Select data source | 4 [Import] button |
| 2 [...] button | 5 Patient list |
| 3 Previous examinations | |

Abb. 10-6: "Import" dialog



The default options for import and export of data are configured in the "Settings" field, see also the *User Guide*.

→ Depending on the settings, you may not have to perform all of the following steps (e.g. selection of the directory).

→ Select the option (1) where the source data are contained ("Folder" or "U12" (single file)).



Recommendation: Import the patient data using the "Single file (U12)" option.

→ Press the [...] button. (2).

→ In the dialog box, select the directory or the file where the patient data are located.

→ Confirm your selection with [OK] or [Open].

The patients and the associated examinations that are found are displayed in the lower part of the dialog.

→ To import the data, press the [Import] button (4).

The data will then be available in the Patient Data Management system.

10.8 Data Backup

You should make a backup copy of patient and examination data at regular intervals. In case of loss of data, you can reconstruct the data from a previously created backup with the help of this function. Since data backup takes several minutes, depending on the scope of the database and the data to be backed up, a backup should be carried out when the computer and the device are not in use.



Note

Risk of loss of data due to computer viruses

Computer viruses can cause loss of data.

→ Run a virus check before making a backup to a USB flash drive.



The general rules for security backups apply to the creation of backup copies created with the help of the Patient Data Management system. Storage of backup files should always be done on a separate system (for example on a USB flash drive with adequate capacity).

10.8.1 Backup Data

➔ Press the [Backup] button at the top right of the Patient Data Management system. The following dialog appears:

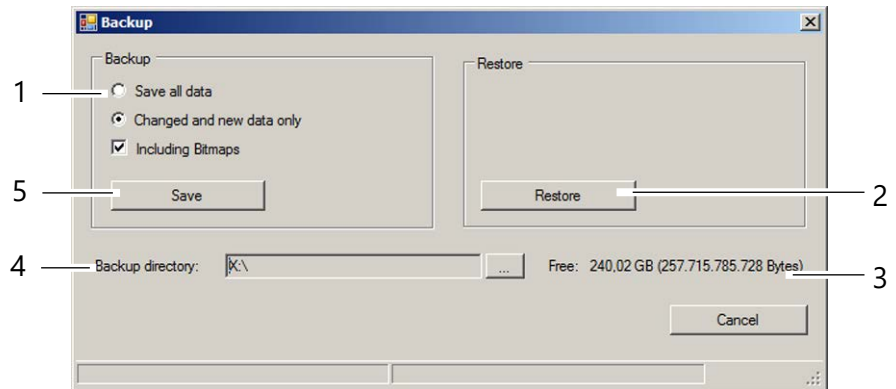

- | | |
|------------------------------|-------------------------------------|
| 1 Backup data selection | 4 Backup directory and button [...] |
| 2 [Restore] button | 5 [Save] button |
| 3 Display free storage space | |

Abb. 10-7: "Backup" dialog

➔ Select whether all of the data or only changed data should be backed up.



The Patient Data Management system internally tags all saved data records.

If you select the option "Changed and new data only", only the data records that were not saved will be backed up.

- ➔ Press the [...] button to the right of the "Backup directory" box (4).
- ➔ In the dialog that appears, select the folder to which the data should be backed up.
- ➔ Confirm your selection with [OK].
- ➔ To back up the data, press the [Save] button (5). The previously selected data will then be backed up to the corresponding folder.

10.8.2 Reconstructing Data

If a loss of data occurs, the data from a previous backup can be re-imported into the Patient Data Management system.

- ➔ Press the [...] button.
- ➔ In the dialog that appears, select the folder which contains the backup data.
- ➔ Confirm your selection with [OK].
- ➔ To import the data, press the [Restore] button (2). All data in the appropriate directory are copied to the Patient Data Management system.

10.8.3 Automatic Backup

In addition to the manually performed backup, it is also possible to automatically run a backup when exiting the Patient Data Management system. The settings required for this can be made in the "Settings" area, see [User Guide](#).

11 Cleaning, Disinfection and Maintenance

Cleaning of the OCULUS Easygraph is described in this chapter. No sterilization is required.

- Heed the product descriptions and instruction manuals of products and equipment you use to care for, clean, and disinfect the unit and/or its accessories.
- Do not clean the OCULUS Easygraph with aggressive, chlorine containing, abrasive or sharp cleaning agents.

11.1 Cleaning



Attention

Risk of electric shock if the OCULUS Easygraph is not completely disconnected from the mains for these jobs.

- Turn the OCULUS Easygraph off, [sec. 8.3, page 25](#).
- Pull the power plug before cleaning. When disconnecting electrical connections, pull on the respective plug and not on the cable itself.

Required materials:

- Cleaner with anti-static effect for plastic surfaces
- Cleaner for painted surfaces: Mixture of equal parts of alcohol and distilled water, possibly with a few drops of household detergent
- Soft, lint-free cloth

Cleaning intervals

- Clean the components of the OCULUS Easygraph once a month or if necessary.

Cleaning the Frame of the Reflector

- Clean the frame of the reflector and the blue gripping surfaces after every examination.

Cleaning the Housing

- It is best to clean the housing surfaces with a soft cloth and an anti-static cleaning agent.
- Wipe off any residue from painted surfaces with the mixture for painted surfaces.

Cleaning the Chin Rest and the Forehead Rest

- Make sure that no liquid gets into any of the openings of the OCULUS Easygraph.
- Clean the chin-forehead rest with a soap solution (or with alcohol, if very dirty).
- Use a lint-free, damp cloth.

Cleaning the Placido Bowl

The Placido bowl is a precision component and is pressure-sensitive. The surfaces of these components are susceptible to scratching.

- ➔ Take special care when cleaning the surface of the Placido bowl. Use a lint-free, dry cloth.
- ➔ Make sure that no dust gets into the little holes.
- ➔ If necessary, carefully clean the Placido bowl with a barely damp cloth.

11.2 Disinfection



Attention

Risk of electric shock if the OCULUS Easygraph is not completely disconnected from the mains for these jobs.

- ➔ Turn the OCULUS Easygraph off, [sec. 8.3, page 25](#).
- ➔ Pull the power plug before cleaning. When disconnecting electrical connections, pull on the respective plug and not on the cable itself.

- Recommendation: Use disinfection wipes suitable for medical devices., for example:
 Mikrozid sensitive wipes premium
 Fa. Schülke & Mayr
 Softpack 48 pieces; Art.Nr. 165711
 Schülke & Mayr GmbH
 Telefon: +4940521000; Telefax: +494052100318
 mail@schuelke.com
 www.schuelke.com



Note

Equipment damage caused by disinfectant solution

The disinfectant solution may damage the surface of the device if it is sprayed directly on it.

- ➔ Spray the disinfectant solution onto a cleaning cloth, do not spray it directly on the device.

- ➔ Turn the OCULUS Easygraph off, [sec. 8.3, page 25](#).
- ➔ Disinfect the forehead rest after each examination, disinfect the housing if necessary.
- ➔ If you do not use chin rest paper, disinfect the forehead rest after each patient.

11.3 Maintenance

The OCULUS Easygraph is designed so that no special maintenance is necessary. For safety reasons, we recommend that the illumination and electrical values be checked every two years.

- ➔ Please contact OCULUS Service for this.

11.4 Attaching Paper to the Chin Rest

If you want to attach new chin rest paper, follow these instructions:

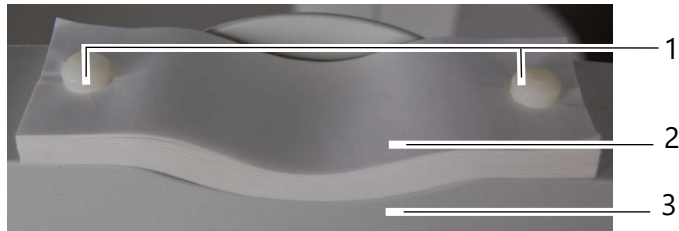

- 1 Pins
2 Paper for chin support
3 Chin rest

Abb. 11-1: Fasten chin rest paper

- ➔ Pull the two pins (1) out of the chin rest.
- ➔ Place the chin rest paper (2) in such a way that the holes of the paper and those in the chin rest (3) are aligned.
- ➔ Insert the two pins (1) in the chin rest.

11.5 Reference Measurement

In order to achieve a high level of measuring accuracy and to ensure this in a long term, a reference measurement must be carried out. The OCULUS Easygraph must be set up

- before the first examination of a patient
- always after a change of location of the device
- once a month

When setting up the device, OCULUS Service or an authorized dealer will carry out the first reference measurement.

The reference measurement can be performed easily and quickly using the reference sphere ($r = 8,000 \text{ mm}$).

Required Materials:

- Reference sphere ($r=8,000 \text{ mm}$), provided
- Cleaning alcohol

Prerequisite: the OCULUS Easygraph must be turned on for at least 15 minutes.

For the reference measurement, proceed as follows:

- ➔ Thoroughly clean the reference sphere before saving reference values (e.g. with cleaning alcohol).
- ➔ Fasten the sphere holder to the chin-forehead rest.



Abb. 11-2: Parallel alignment of the reference sphere

- Align the height based on the marks.
 - Align the reference sphere parallel.
 - In the [Settings] menu, select the [Reference Measure] menu item.
 - Perform a measuring operation with the reference sphere ([sec. 9.6, page 31](#)).
 - Confirm the question "Calibration done" with [OK].
 - Follow the displayed message.
 - Turn the reflector to the position for the other eye.
 - Repeat the reference measurement.
 - Confirm the question "Calibration done" with [OK].
- The system is now ready for operation.

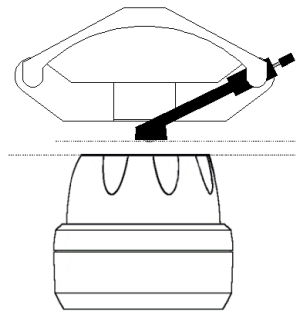

Note

If the error message "Reference sphere not completely measured!" appears, the sphere must be carefully cleaned and the measuring operation repeated.

The system is now ready for operation. The reference data is stored directly on the device, so that the measuring head is not dependent on a particular computer or laptop.

12 Troubleshooting



Attention

Risk of personal injury or equipment damage due to improper troubleshooting

- If an error occurs which you are unable to correct by following the instructions below, label the device as "out-of-order" and contact our service department or an authorized dealer.

Error	Possible Cause	Remedy
After starting the OCULUS Easygraph program the dialog box opens: "No communication with the OCULUS Easygraph!"	No power to the power adapter.	Check whether the power adapter is properly working.
	Connection cable (Y cable) OCULUS Easygraph/Power Adapter/computer/Laptop are not plugged in properly.	Check whether <ul style="list-style-type: none"> ■ the connector is properly plugged into the OCULUS Easygraph ■ the USB connector is correctly plugged into the computer/laptop ■ the connector for the low voltage side of the power adapter is plugged in
	Software/Hardware problems.	Disconnect the mains plug of the OCULUS Easygraph and restart the computer. Plug in the mains plug of the OCULUS Easygraph as soon as the Patient Data Management becomes active. When you start the OCULUS Easygraph program, the message "Load Bootloader" must appear.
After starting the OCULUS Easygraph program the message appears that the License Key is not inserted.	License Key is not inserted	Insert the License Key into the USB-connector of your computer or the Floating License Key in the server.

13 Transport and Storage

The OCULUS Easygraph, must be properly dismantled and packed before being transported or stored.



Attention

Risk of equipment damage due to incorrect shipment or from improper storage

- Avoid shocks, vibrations, and contamination.
 - Avoid high temperatures and humidity.
-
- Transport the OCULUS Easygraph carefully.
 - Do not hold the device by the joystick to carry it.
 - Store the OCULUS Easygraph in compliance with the storage conditions.
 - Avoid placing near heaters and moisture.
 - Wait approx. 3-4 hours after transport before putting the OCULUS Easygraph into initial operation. Extreme temperature changes from cold areas to warm rooms can cause condensation on the optical components.

13.1 Storage Conditions

Ambient temperature range	-10°C to +55°C
Relative humidity, including condensation	10% to 95%
Air pressure range	700 hPa to 1060 hPa

13.2 Transport Conditions

Ambient temperature range	-40°C to +70°C
Relative humidity, including condensation	10% to 95%
Air pressure range	500 hPa to 1060 hPa

13.3 Disassembly

- End the current session.
- Pull the y cable out of the computer/laptop and the power supply.
- Loosen the screw connection of the y cable. Hold the plug sleeve (1) and pull out the plug.



Abb. 13-1: Deconnect

When disconnecting electrical connections, pull on the respective plug and not on the cable itself.

14 Disposal



In accordance with Directive 2012/19/EC of the European Parliament and the Council, and in accordance with German law governing the marketing, return and environmentally compatible disposal of used electrical and electronic devices, such appliances must be recycled and may not be discarded as household waste.

- Dispose the OCULUS Easygraph in a compliant manner.

15 Terms of Warranty and Servicing

15.1 Terms of Warranty

Please note the following warranty provisions:

- Prior to and while operating the device it is important that you heed the instruction manual and safety instructions.
- In accordance with legal regulations, you are entitled to a warranty for the OCULUS Easygraph.
- If modifications are made to the OCULUS Easygraph by unauthorized persons, all warranty claims shall be voided. Improper modifications and repairs may result in considerable hazards to users and patients.
- Any entitlement to a warranty shall also be void if unauthorized persons interfere with the supplied computer hardware and software.
- Any transport damage must be reported immediately to the shipping company. Have the transport damage noted on the bill of lading so that complaint handling and compensation of damages can proceed in an orderly manner.
- In general, our Business and Shipping Terms on the date of purchase apply.

15.2 Assumption of Liability for Functions and Damage

OCULUS will only accept responsibility for the safety, reliability and serviceability of the OCULUS Easygraph if the unit is used in compliance with the following terms:

- Only use the equipment in conformance with this instruction manual.
- There are no parts either on or inside the OCULUS Easygraph that require maintenance or repair by the user. If assembly work, modifications, adjustments, repairs, changes or service are performed by unauthorized personnel, or if the OCULUS Easygraph is improperly maintained or handled, then any liability by OCULUS is voided.
- If the above-referenced work is performed by authorized persons, request a certification of the scope and type of repair, and, if necessary, the changes to the standard values or to the operating range from the service technician. This certification must contain the date of performance and statement of the performing firm, with signature.
- If requested, OCULUS will provide the service technician with a list of spare parts and additional descriptive material for this purpose.
- Make certain that only original OCULUS parts are used.

16 Technical Data

Measuring Equipment

Measuring range	3 to 38 mm 9 to 99 D
Accuracy	± 0.1 D
Reproducibility	± 0.1 D
Number of rings	22
Working distance	40 mm
Number of analyzed data points	22000
Dimensions (W x D x H)	119 x 102 x 216 mm (4.7 x 4.0 x 8.5 in)
Weights	730 g (1.6. lbs)
Max. power consumption	6 W
Interface	USB
Life expectancy	up to 10 years

Power Adapter¹

Power adapter	GEM18I05-P1J (05150980)
Mains connection	80 - 264V AC,
Frequency	47 – 63 Hz
Max. power consumption	115 VA
Output voltage	5 V DC; 3 A; max. 15 W
Fuses	Integrated overcurrent shut-off

Classification according to IEC 60601 - 1

Type of protection against electric shock	Protection class 2
Level of protection against electric shock	Type B
Level of protection against harmful penetration of water	IP20

Software version

- Patient data management: from version 6.08
- OCULUS Easygraph-Software: from version V2.10r 5



- The software version of the patient data management is displayed on the Settings-General screen page (patient data management).
- The software version of the OCULUS Easygraph program is displayed in the [Help] menu, menu item "About..."

Computer

Use a computer which is in conformity with the DIN EN 62368-1 or DIN EN 60950 standard.

Recommended computer specifications

Intel® Core™ i5-6600, 500 GB HDD, 8 GB RAM, Windows® 10Pro

CE in accordance with EC Directive 93/42/EEC for Medical Devices

The unit is a class IIa product.



Conformity assessment: Directive 93/42 / EEC: Annex II without section 4.

17 Annex

17.1 Electromagnetic Compatibility

Medical electrical equipment is subject to special precautionary requirements with respect to EMC, and must be installed and operated according to the EMC-Instructions contained in the accompanying paperwork.

No special measures need be observed in respect of OCULUS devices and systems.

Portable and mobile RF-communications devices can interfere with electrically operated medical devices.

The device is intended to be used in a professional health care facility environment.

Minimal performance quality and essential performance criteria

- A slightly disturbance of the analog camera of the OCULUS Easygraph (slightly image noise on screen) during the examination is permissible because it will not affect the diagnosis, treatment and observation.
- A short flicker of the illumination of the OCULUS Easygraph during the examination is permissible because it will not affect the diagnosis, treatment and observation.
- A short interruption of the USB connection during the examination is permissible because it will not affect the diagnosis, treatment and observation.



Attention

The use of accessories, transducers and cables not specified by OCULUS (for example as replacement parts) may result in increased emissions or decreased immunity of the OCULUS Easygraph.

- ➔ Use only the original accessories, transducers and cables specified by OCULUS.

The use of accessories, transducers and cables specified by OCULUS with devices other than the OCULUS Easygraph may result in increased emissions or decreased immunity of the other device.

- ➔ Do not use the accessories, transducers and cables specified by OCULUS with devices other than the OCULUS Easygraph.

To be in compliance with the requirements of the IEC 60601-1-2 the following types of equipment, accessories, power adapters and cables must be used.

Order number	Description	
70620	OCULUS Easygraph	
05200320	Cable with connector plug, EU standard	2.5 m (98.4 in)
05200210 (110 Volt)	Cable with connector plug, US standard	2.5 m (98.4 in)

Order number	Description	
05150980	Power adapter	
02 70620 00 071	Connection cable (Y cable EG GI-FS)	6 m (236.2 in)

The use of accessories and cables not approved or supplied by OCULUS can cause malfunctions and reduce the interference resistance of the OCULUS Easygraph.

Keep the unit away from accessory components listed in the EMC tables.

17.2 Guidance and Manufacturer's Declaration - Electromagnetic Emissions and Immunity for the OCULUS Easygraph

Guidance and manufacturer's declaration electromagnetic emissions IEC 60601-1-2: 2015, based to table 1		
The OCULUS Easygraph is intended for operation in the electromagnetic environment specified below. The user of the OCULUS Easygraph should ensure that it is being used in such an environment.		
Emissions test	Compliance	Electromagnetic environment - guidance
RF emissions CISPR 11	Group 1	The OCULUS Easygraph uses RF energy only for its internal function. Therefore, its RF emissions are very low and are not likely to cause any interference in nearby electronic equipment.
HF-emissions CISPR 11	Class B	
Harmonics emissions IEC 61000-3-2	Class A	
Voltage fluctuations / flicker emissions IEC 61000-3-3	complies	

Electromagnetic immunity, IEC 60601-1-2: 2015, based on table 4

Immunity test	IEC 60601 test level	Compliance level	Electromagnetic environment - guidance
Electrostatic discharge (ESD) IEC 61000-4-2	± 8 kV contact ± 15 kV air	± 8 kV ± 15 kV	Floors should be made of wood or concrete or covered with ceramic tiles. If the floor is covered with synthetic material, the relative humidity must be at least 30%.
Power frequency (50/60Hz) magnetic field IEC 61000-4-8	30 A/m 50 Hz or 60 Hz	30 A/m 50 Hz or 60 Hz	Power frequency magnetic fields should be at levels characteristic of a typical location in a typical commercial or hospital environment.

Electromagnetic immunity, IEC 60601-1-2: 2015, based on table 5, 8

Electrical Fast transient/bursts IEC 61000-4-4	± 2 kV for power supply lines 100 kHz repetition frequency ± 1 kV for input/output lines	± 2 kV ----- ± 1 kV	Mains power quality should be that of a typical commercial or hospital environment.
Surge IEC 61000-4-5	± 1 kV line(s) to line(s) ± 2 kV line(s) to earth	± 1 kV differential mode ± 2 kV line(s) to earth	Mains power quality should be that of a typical commercial or hospital environment.
Voltage dips, short interruptions, and voltage variations on power supply input lines IEC 61000-4-11	0% U_{Ti} : 1/2 period at 0, 45, 90, 135, 180, 225, 270 and 315 degree 0% U_{Ti} : 1 period and 70% U_{Ti} : 25/30 periods Single-phase: at 0 degree 0% U_{Ti} : 250/300 periods	0% U_{Ti} : 1/2 period at 0, 45, 90, 135, 180, 225, 270 and 315 degree 0% U_{Ti} : 1 period and 70% U_{Ti} : 25/30 periods Single-phase: at 0 degree 0% U_{Ti} : 250/300 periods	Mains power quality should be that of a typical commercial or hospital environment. If the user of the OCULUS Easygraph requires continued operation during power mains interruptions, it is recommended that the OCULUS Easygraph be powered from an uninterruptible power supply or battery.

Note: U_T is the a.c. mains voltage prior to application of the test level.

Recommended separation distances between portable and mobile RF communications equipment and the OCULUS Easygraph, IEC 60601-1-2:2007, table 6

The OCULUS Easygraph is intended for use in an electromagnetic environment in which radiated RF disturbances are controlled. The customer or the user of the OCULUS Easygraph can help prevent electromagnetic interference by maintaining a minimum distance between portable and mobile RF communications equipment (transmitters) and the OCULUS Easygraph as recommended below, according to the maximum output power of the communications equipment.

Rated maximum output power of transmitter W	Separation distance according to frequency of transmitter m		
	150 KHz to 80 MHz $d = 1.2 \sqrt{P}$	80 MHz to 800 MHz $d = 1.2 \sqrt{P}$	800 MHz to 2.5 GHz $d = 2.3 \sqrt{P}$
0.01	0.12	0.12	0.23
0.1	0.38	0.38	0.73
1	1.2	1.2	2.3
10	3.80	3.80	7.3
100	12	12	23

For transmitters rated at a maximum output power not listed above, the recommended separation distance d in metres (m) can be estimated using the equation applicable to the frequency of the transmitter, where P is the maximum output power rating of the transmitter in watts (W) according to the transmitter manufacturer.

NOTE 1: At 80 MHz and 800 MHz, the separation distance for the higher frequency range applies.

NOTE 2: These guidelines may not apply in all situations. Electromagnetic propagation is affected by absorption and reflection from structures, objects and people.

17.3 Connection-Diagram

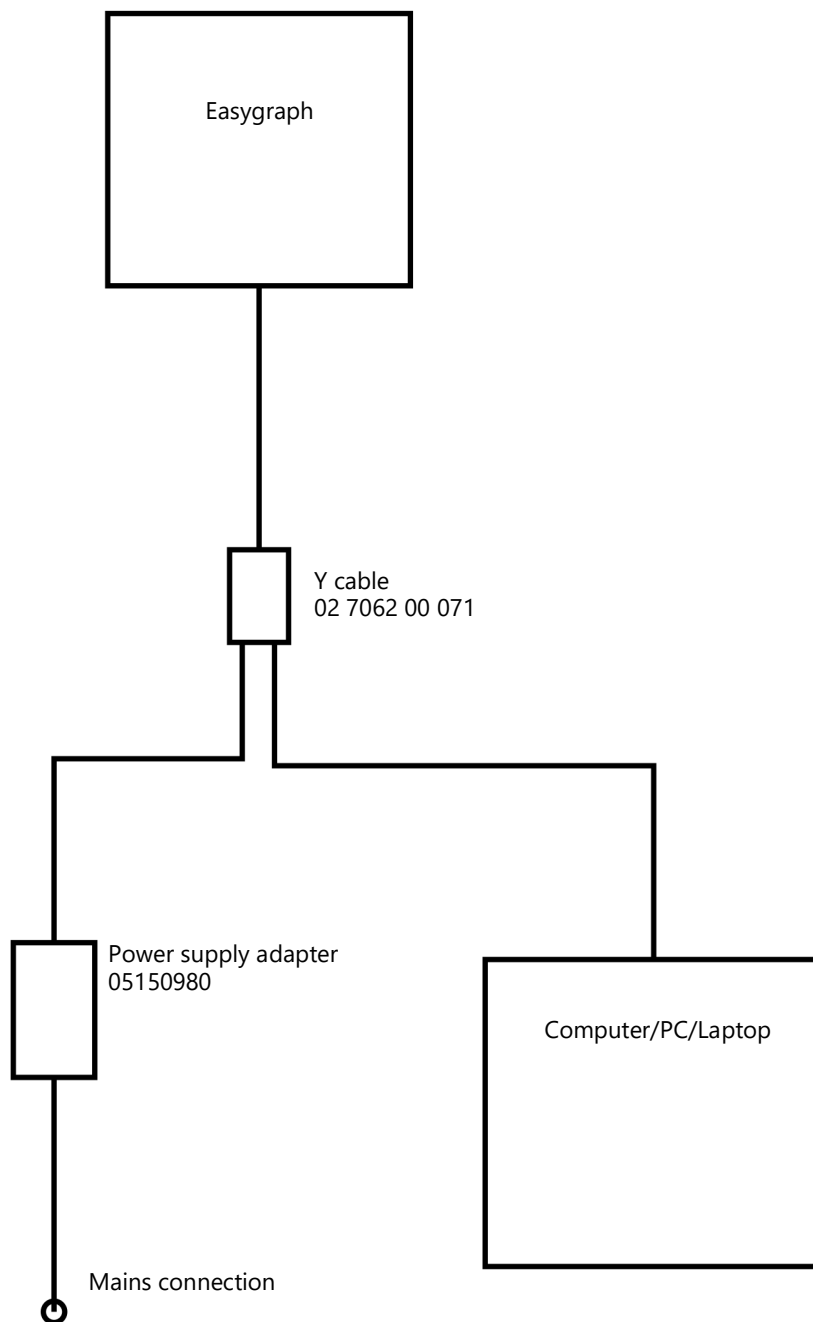

17.4 Data Sheet GEM 181 (05150980)



18W AC-DC High Reliability Interchangeable Medical Adaptor **GEM18I** series



■ Features

- Interchangeable AC plugs (plug kit sold sperately)
- Medical safety approved (2 × MOPP between primary to secondary)
- Suitable for BF application with appropriate system consideration
- Low leakage current <100 μ A
- No load power consumption< 0.075W
- Energy efficiency Level VI
- Comply with EISA 2007/DoE and EU ErP
- Class II power (without earth pin)
- Protections: Short circuit / Overload / Over voltage
- Fully enclosed plastic case
- Optional lock type DC plug
- 100% full load burn-in test
- 3 years warranty

■ Applications

- Blood glucose meter
- Blood pressure meter
- Nebulizer
- Inhaler
- Portable medical device
- Sleep apnea devices

■ Description

GEM18I is a highly reliable, 18W wall-mounted style single-output green medical adaptor series, which is compact and convenient for carry. This product is equipped with an interchangeable AC plug (4 types, including European type, USA type, U.K. type and Australian type) that makes it very suitable for businessmen to use in the major countries around the globe. GEM18I is a class II power unit (without FG), accepting the input range from 80VAC to 264VAC that it can satisfy the demands for various types of medical electrical devices. The circuitry design meets the international medical standards (2*MOPP), having an ultra low leakage current (<100 μ A), fitting the medical devices in direct electrical contact with the patients.

With the working efficiency up to 87% and the extremely low no-load power consumption below 0.075W, GEM18I is compliant with the latest USA energy regulation EISA 2007/DoE (Level VI) and EU ErP. The supreme feature allows the adaptor to save the energy when it is under either the operating mode or the standby mode. The entire series is approved for international safety regulations; moreover, it adopts the 94V-0 flame retardant plastic case that it can effectively prevent users from electric hazard.

■ Model Encoding

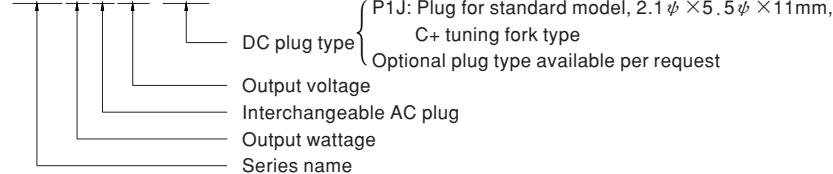

GEM18 I 05 - P1J



File Name:GEM18I-SPEC 2015-05-05

 18W AC-DC High Reliability Interchangeable Medical Adaptor **GEM18I** series

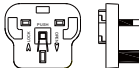
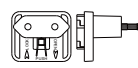
Interchangeable AC plug Specifically for GEM18I

TYPE					
ORDER NO.	AC plug-AU2	AC plug-UK2	AC plug-EU2	AC plug-US2	AC plug-MIX2

SPECIFICATION

ORDER NO.		GEM18I05-P1J	GEM18I09-P1J	GEM18I12-P1J	GEM18I15-P1J	GEM18I18-P1J	GEM18I24-P1J	GEM18I48-P1J	
OUTPUT	SAFETY MODEL NO.	GEM18I05	GEM18I09	GEM18I12	GEM18I15	GEM18I18	GEM18I24	GEM18I48	
	DC VOLTAGE <small>Note.2</small>	5V	9V	12V	15V	18V	24V	48V	
	RATED CURRENT	3A	2A	1.5A	1.2A	1A	0.75A	0.38A	
	CURRENT RANGE	0 ~ 3A	0 ~ 2A	0 ~ 1.5A	0 ~ 1.2A	0 ~ 1A	0 ~ 0.75A	0 ~ 0.38A	
	RATED POWER (max.)	15W	18W	18W	18W	18W	18W	18W	
	RIPPLE & NOISE (max.) <small>Note.3</small>	60mVp-p	60mVp-p	80mVp-p	80mVp-p	80mVp-p	80mVp-p	80mVp-p	
	VOLTAGE TOLERANCE <small>Note.4</small>	±5.0%	±5.0%	±3.0%	±3.0%	±2.0%	±2.0%	±2.0%	
	LINE REGULATION <small>Note.5</small>	±1.0%	±1.0%	±1.0%	±1.0%	±1.0%	±1.0%	±1.0%	
	LOAD REGULATION <small>Note.6</small>	±5.0%	±5.0%	±3.0%	±3.0%	±2.0%	±2.0%	±2.0%	
	SETUP, RISE, HOLD UP TIME	500ms, 30ms, 16ms/230VAC 500ms, 30ms, 16ms/115VAC at full load							
INPUT	VOLTAGE RANGE <small>Note.7</small>	80 ~ 264VAC		113 ~ 370VDC					
	FREQUENCY RANGE	47 ~ 63Hz							
	EFFICIENCY (Typ.)	80%	84%	84%	84%	84%	85%	87%	
	AC CURRENT	0.45A / 115VAC		0.25A / 230VAC					
	INRUSH CURRENT (max.)	30A / 115VAC		60A / 230VAC					
	LEAKAGE CURRENT(max.)	Touch current < 100 μ A/264VAC							
PROTECTION	OVERLOAD	105 ~ 160% rated output power Protection type : Hiccup mode, recovers automatically after fault condition is removed							
	OVER VOLTAGE	110 ~ 140% rated output voltage Protection type : Clamp by zener diode, output short							
ENVIRONMENT	WORKING TEMP.	-20 ~ +50 $^{\circ}$ C (Refer to "Derating Curve")							
	WORKING HUMIDITY	20% ~ 90% RH non-condensing							
	STORAGE TEMP., HUMIDITY	-20 ~ +85 $^{\circ}$ C, 10 ~ 95% RH							
	TEMP. COEFFICIENT	±0.03% / $^{\circ}$ C (0 ~ 40 $^{\circ}$ C)							
SAFETY & EMC <small>(Note. 8)</small>	VIBRATION	10 ~ 500Hz, 2G 10min./1cycle, period for 60min. each along X, Y, Z axes							
	SAFETY STANDARDS	ANSI/AAMI ES60601-1 / 60601-1-11, TUV EN60601-1 / 60601-1-11 approved							
	WITHSTAND VOLTAGE	I/P-O/P:5656VDC							
	ISOLATION RESISTANCE	I/P-O/P:100M Ohms / 500VDC / 25 $^{\circ}$ C / 70% RH							
	EMC EMISSION	Compliance to EN55011 class B, EN61000-3-2,3, FCC PART 15 / CISPR22 class B							
OTHERS	EMC IMMUNITY	Compliance to EN61000-4,-2,3,4,5,6,8,11, light industry level, criteria A							
	LIFE	3 years : 100% load 40 $^{\circ}$ C, 12hours / day							
	MTBF	400Khrs min. MIL-HDBK-217F(25 $^{\circ}$ C)							
	DIMENSION	75.5*39.1*56.2mm (L*W*H)							
CONNECTOR	PACKING	140g ; 60pcs / 14kg / CARTON							
	PLUG	See page 3 ; Other type available by customer requested							
NOTE	CABLE	See page 3 ; Other type available by customer requested							
		1.All parameters are specified at 230VAC input, rated load, 25 $^{\circ}$ C 70% RH ambient. 2.DC voltage: The output voltage set at point measure by plug terminal & 50% load. 3.Ripple & noise are measured at 20MHz by using a 12" twisted pair terminated with a 0.1uf & 47uf capacitor. 4.Tolerance: includes set up tolerance, line regulation, load regulation. 5.Line regulation is measured from low line to high line at rated load. 6.Load regulation is measured from 10% to 100% rated load. 7.Derating may be needed under low input voltage. Please check the derating curve for more details. 8.The power supply is considered as an independent unit, but the final equipment still need to re-confirm that the whole system complies with the EMC directives. For guidance on how to perform these EMC tests, please refer to "EMI testing of component power supplies." (as available on http://www.meanwell.com)							

File Name:GEM18I-SPEC 2015-05-05



18W AC-DC High Reliability Interchangeable Medical Adaptor **GEM18I** series

Derating Curve

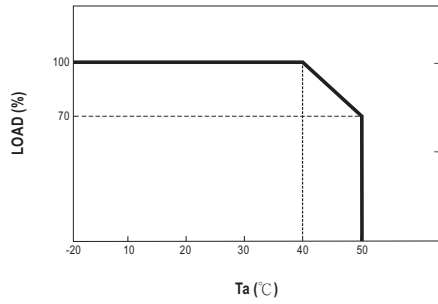

Static Characteristics

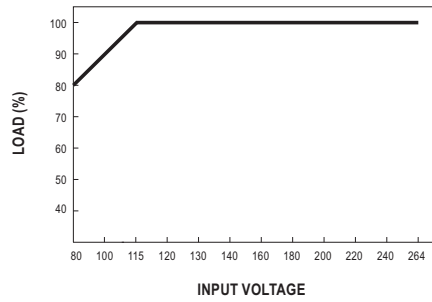

Mechanical Specification

Unit:mm

TYPE	Australian type	U.K type	European type	US type

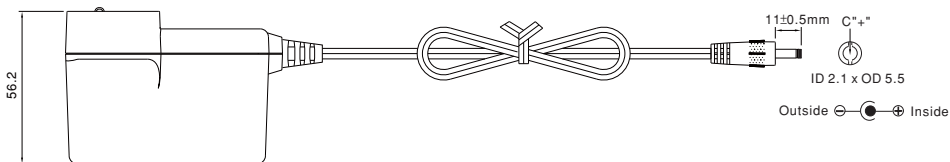
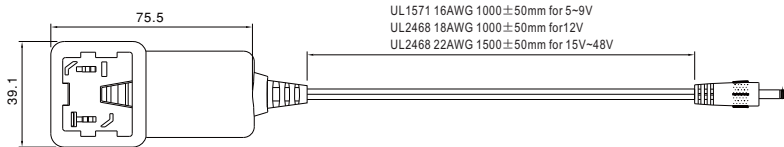

Plug Assignment

Standard plug: P1J

P1J	
P/N	OUTPUT
CENTER	+

Optional lock type plug: P2S
SWITCHCRAFT S761K plug equivalent

Installation Manual

Please refer to : <http://www.meanwell.com/webnet/search/InstallationSearch.html>

File Name:GEM18I-SPEC 2015-05-05

WWW.OCULUS.DE

OCULUS Optikgeräte GmbH

Münchholzhäuser Str. 29 • 35582 Wetzlar • GERMANY

Phone +49 641 2005-0 • Fax +49 641 2005-255

E-mail: sales@oculus.de • www.oculus.de

G/70620/XXXX/EN / Rev02
Lot: 